

# Product data sheet

Specifications



## Regulated Power Supply, 380...500V AC, 24V, 20A, 3 phases, Universal

ABLU3A24200

### Main

Range of product	Modicon Power Supply
Product or component type	Power supply
Power supply type	Regulated switch mode
Variant option	Universal
Enclosure material	Metal
Nominal input voltage	380...500 V AC three phase
Rated power in W	480 W
Output voltage	24 V DC
Power supply output current	20 A
Permissible temporary current boost	1.5 x In for 5 seconds)

### Complementary

Input voltage limits	320...575 V AC 3 phases
Nominal network frequency	50...60 Hz
Network system compatibility	TN TT IT
Maximum leakage current	2 mA 500 V AC
Input protection type	Integrated fuse (not interchangeable) 3.15 A External protection (recommended)
Inrush current	35 A 380 V 35 A 500 V
Power factor	0.90 at 380 V AC 0.88 at 500 V AC
Efficiency	93 % 380 V AC 93 % 500 V AC
Output voltage adjustment	24...28 V
Power dissipation in W	33 W
Current consumption	< 0.85 A 380 V AC < 0.73 A 500 V AC
Turn-on time	< 1 s
Holding time	> 20 ms 380 V AC > 20 ms 500 V AC
Startup with capacitive loads	200000 µF
Residual ripple	< 150 mV

<b>Meantime between failure [MTBF]</b>	876500 h at 77 °F (25 °C), full load conforming to SR 332 374800 h at 131 °F (55 °C), 80 % load conforming to SR 332
<b>Output protection type</b>	Against overload and short-circuits, protection technology: manual or automatic reset by switch Against over temperature, protection technology: automatic reset Against overvoltage, protection technology: manual reset
<b>Connections - terminals</b>	Screw connection 4...6 mm <sup>2</sup> , AWG 12...AWG 10) without wire end ferrule output Screw connection 4 mm <sup>2</sup> , AWG 12) with wire end ferrule output Screw connection 0.75...6 mm <sup>2</sup> , AWG 18...AWG 12) without wire end ferrule input Screw connection 0.75...4 mm <sup>2</sup> , AWG 18...AWG 12) with wire end ferrule input Cage clamp 0.2...1.5 mm <sup>2</sup> , AWG 22...AWG 16) without wire end ferrule diagnostic relay Cage clamp 0.2...0.75 mm <sup>2</sup> , AWG 22...AWG 18) with wire end ferrule diagnostic relay Cage clamp 0.2...0.75 mm <sup>2</sup> , AWG 22...AWG 18) with wire end ferrule shut down input
<b>Line and load regulation</b>	< 0.17 % network 100 % load in line at 77 °F (25 °C) < 0.6 % +/- 0.5 % network 150 % load at 77 °F (25 °C)
<b>Status LED</b>	1 LED (green and red) product status
<b>Depth</b>	5.01 in (127.3 mm)
<b>Height</b>	4.9 in (124 mm)
<b>Width</b>	2.6 in (65 mm)
<b>Product weight</b>	2.54 lb(US) (1.15 kg)
<b>Output coupling</b>	Parallel
<b>Marking</b>	CE UKCA
<b>Mounting support</b>	Top hat type TH35-15 rail IEC 60715 Top hat type TH35-7.5 rail IEC 60715 Double-profile DIN rail
<b>Supply</b>	SELV IEC 60950-1 SELV IEC 60204-1 SELV IEC 60364-4-41
<b>Dielectric strength</b>	4000 V AC input to output 2000 V AC input to ground 1500 V AC output to ground 4000 V AC input to diagnostic relay 500 V AC output to diagnostic relay 1500 V AC diagnostic relay to ground shutdown input not isolated from output
<b>Diagnostic relay</b>	Electromechanical relay 1000.0 mA 30 V
<b>Service life</b>	10 year(s) 104 °F (40 °C) 80 % load
<b>overvoltage category</b>	III II

## Environment

<b>Standards</b>	IEC 62368-1 EN/IEC 61204-3 IEC 61000-6-1 IEC 61000-6-2 IEC 61000-6-3 IEC 61000-6-4 IEC 61000-3-2 EN 61000-3-3 UL 62368-1 CSA C22.2 No 62368-1 CSA C22.2 No 107.1 EN/IEC 62368-1
------------------	--

<b>Product certifications</b>	CE CUL listed CUL recognized RCM CB Scheme EAC KC UKCA CURus
<b>Operating altitude</b>	< 5000 m overvoltage category III overvoltage category II
<b>Shock resistance</b>	150 m/s <sup>2</sup> 11 ms
<b>IP degree of protection</b>	IP20
<b>Ambient air temperature for operation</b>	-13...131 °F (-25...55 °C) without current derating mounting position A < 2000 m 131...158 °F (55...70 °C) with current derating of 3.3 % per °C mounting position A < 2000 m
<b>Electrical shock protection class</b>	Class I
<b>pollution degree</b>	2
<b>Vibration resistance</b>	3.5 mm (f= 3...11.9 Hz) conforming to IEC 60068-2-6 20 m/s <sup>2</sup> (f= 11.9...150 Hz) conforming to IEC 60068-2-6
<b>Electromagnetic immunity</b>	Immunity to electrostatic discharge - test level: 8 kV (contact discharge) conforming to IEC 61000-4-2 Immunity to electrostatic discharge - test level: 15 kV (air discharge) conforming to IEC 61000-4-2 Immunity to conducted RF disturbances - test level: 15 V/m (80 MHz...2 GHz) conforming to IEC 61000-4-3 Immunity to conducted RF disturbances - test level: 5 V/m (2...2.7 GHz) conforming to IEC 61000-4-3 Immunity to conducted RF disturbances - test level: 5 V/m (2.7...6 GHz) conforming to IEC 61000-4-3 Immunity to fast transients - test level: 4 kV (on input-output) conforming to IEC 61000-4-4 Surge immunity test - test level: 4 kV (between power supply and earth) conforming to IEC 61000-4-5 Surge immunity test - test level: 3 kV (between phases) conforming to IEC 61000-4-5 Immunity to conducted RF disturbances - test level: 15 V (0.15...80 MHz) conforming to IEC 61000-4-6 Immunity to magnetic fields - test level: 30 A/m (50...60 Hz) conforming to IEC 61000-4-8 Immunity to voltage dips conforming to IEC 61000-4-11 Disturbing field emission conforming to EN 55016-2-3 Limits for harmonic current emissions conforming to IEC 61000-3-2 conforming to EN 55016-1-2 conforming to EN 55016-2-1
<b>Electromagnetic emission</b>	Conducted emissions IEC 61000-6-3 Radiated emissions IEC 61000-6-4

## Packing Units

<b>Unit Type of Package 1</b>	PCE
<b>Number of Units in Package 1</b>	1
<b>Package 1 Height</b>	6.10 in (15.500 cm)
<b>Package 1 Width</b>	8.27 in (21.000 cm)
<b>Package 1 Length</b>	8.74 in (22.200 cm)
<b>Package 1 Weight</b>	3.252 lb(US) (1.475 kg)
<b>Unit Type of Package 2</b>	S03
<b>Number of Units in Package 2</b>	7
<b>Package 2 Height</b>	11.81 in (30.000 cm)
<b>Package 2 Width</b>	11.81 in (30.000 cm)
<b>Package 2 Length</b>	15.75 in (40.000 cm)

<b>Package 2 Weight</b>	24.097 lb(US) (10.930 kg)
<b>Unit Type of Package 3</b>	P12
<b>Number of Units in Package 3</b>	168
<b>Package 3 Height</b>	31.50 in (80.000 cm)
<b>Package 3 Width</b>	35.43 in (90.000 cm)
<b>Package 3 Length</b>	47.24 in (120.000 cm)
<b>Package 3 Weight</b>	598.917 lb(US) (271.664 kg)

## Environmental Data

Schneider Electric aims to achieve Net Zero status by 2050 through supply chain partnerships, lower impact materials, and circularity via our ongoing “Use Better, Use Longer, Use Again” campaign to extend product lifetimes and recyclability.

[Environmental Data explained >](#)

[How we assess product sustainability >](#)

### Environmental footprint

[Environmental Disclosure](#)

[Product Environmental Profile](#)

## Use Better

### Materials and Substances

Packaging made with recycled cardboard

No

Packaging without single use plastic

No

China RoHS Regulation

[China RoHS declaration](#)

## Use Again

### Repack and remanufacture

[Circularity Profile](#)

[End of Life Information](#)

WEEE

 The product must be disposed on European Union markets following specific waste collection and never end up in rubbish bins

Take-back

No

Dimensions Drawings

Dimensions

---

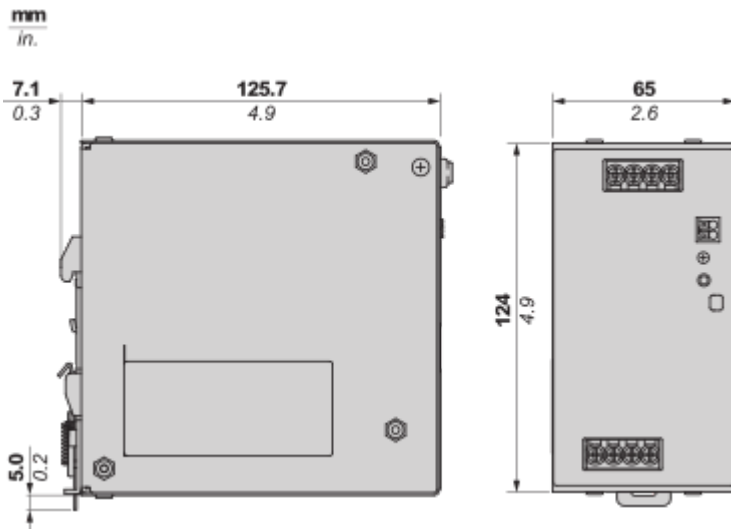

Connections and Schema

Wiring

---

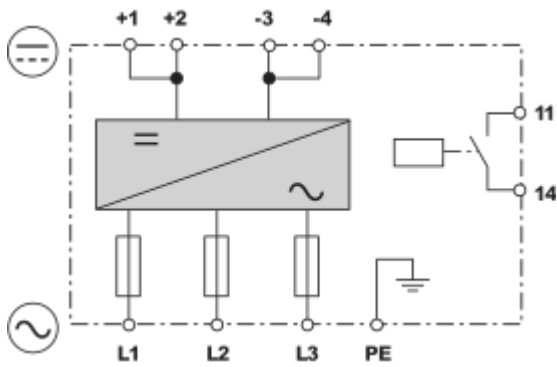

Block Diagram

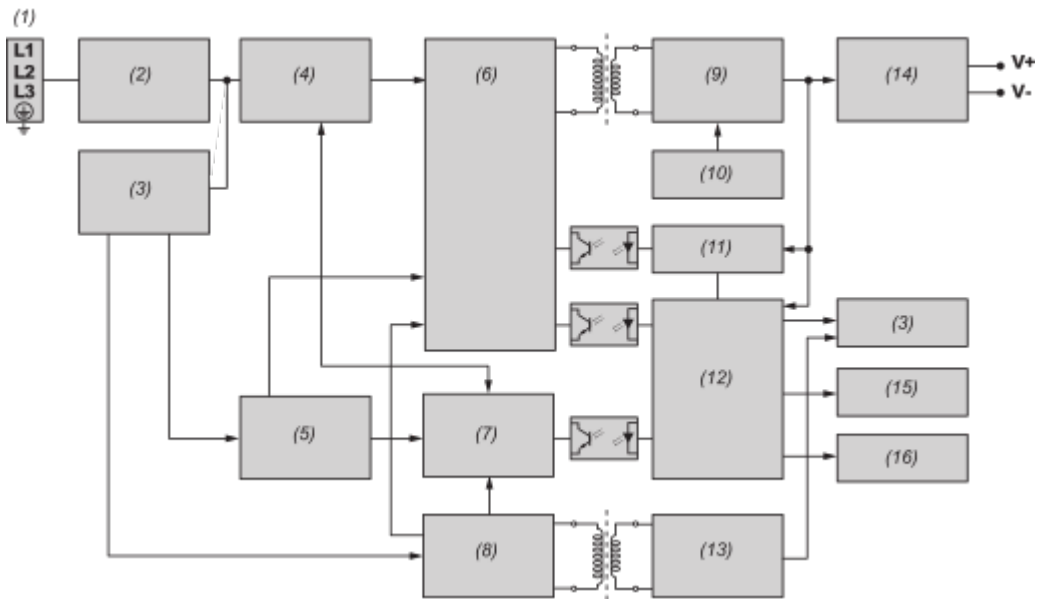

- (1) : Input
- (2) : EMI filter
- (3) : Relay control
- (4) : Interleave PFC converter
- (5) : Primary control
- (6) : Main LLC converter
- (7) : PFC controller
- (8) : Primary AUX
- (9) : Synchronous rectifier
- (10) : SR controller
- (11) : CV & CC feedback
- (12) : Secondary MCU
- (13) : Secondary AUX
- (14) : Output filter
- (15) : Automanual switch
- (16) : LED control

Mounting and Clearance

Mounting

Mounting Position

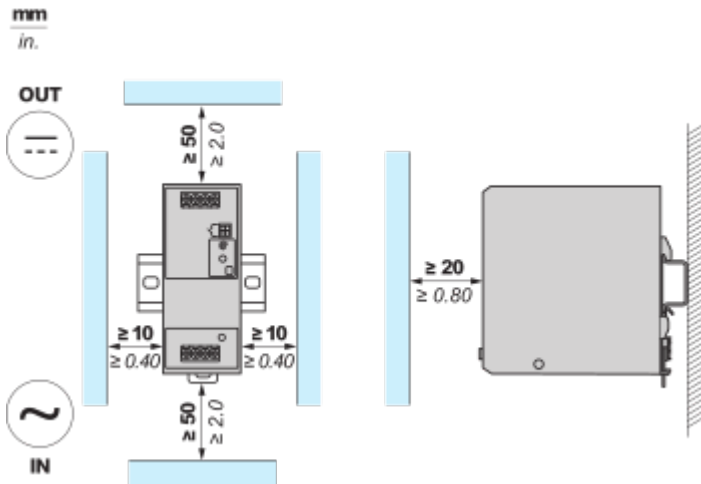

Incorrect Mounting

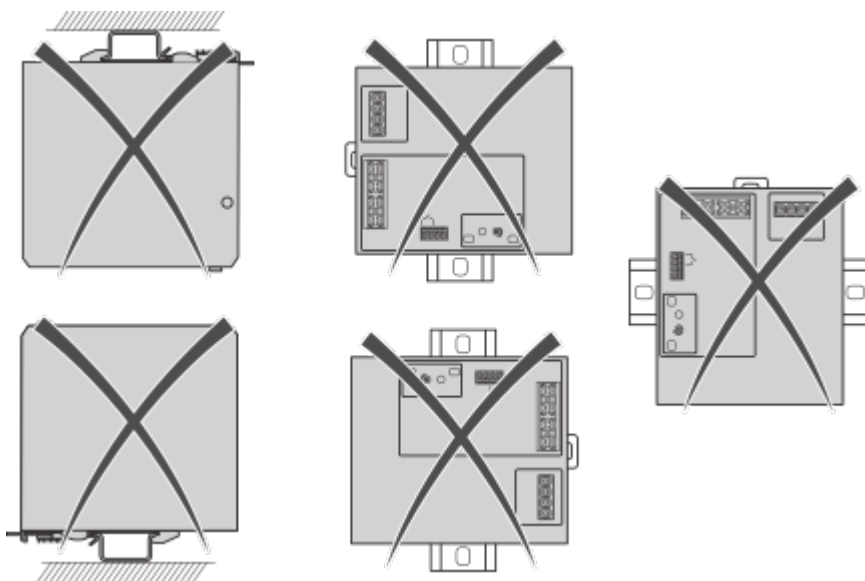

Performance Curves

Performance Curve

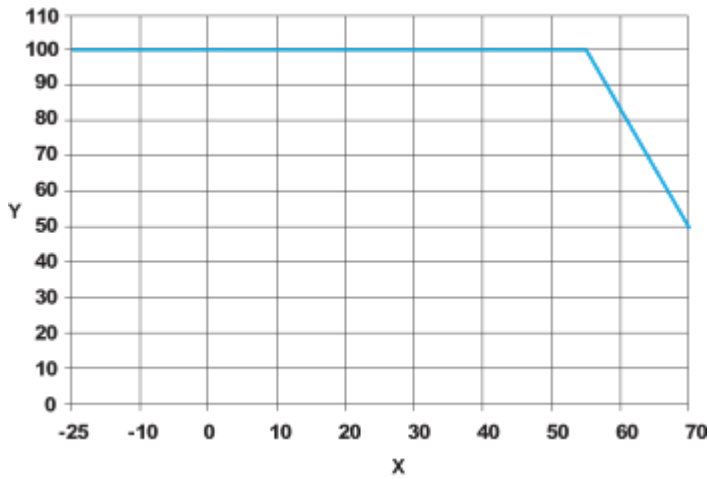

X : Surrounding Air Temperature (°C)  
 Y : Percentage of Maximum Load (%)

Overvoltage Protection Behavior

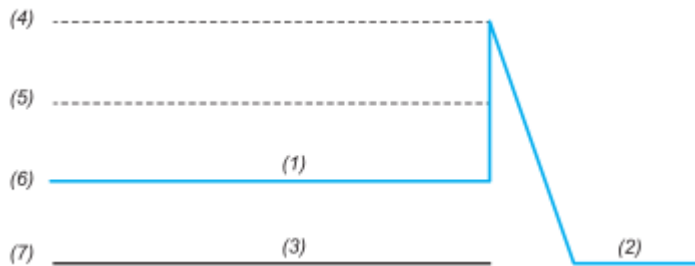

Overvoltage range : 26...36 VDC, Latch Mode

- (1) : Variable output voltage range
- (2) : Latch
- (3) : Typical overvoltage condition as seen at the output
- (4) : Maximum overvoltage protection level
- (5) : Overvoltage protection
- (6) : Norminal output voltage
- (7) : Zero output