

MOS 12-28VDC 100KHZ

Weidmüller Interface GmbH & Co. KG

Klingenbergstraße 26

D-32758 Detmold

Germany

www.weidmueller.com



Compact and powerful solid-state relays in terminal block format

Saving space in the panel is becoming more and more important, and requires increasingly compact components. With the compact and powerful MICROOPTO solid-state relays, you benefit from our decades of experience in manufacturing products in terminal block format. The MICROOPTO family comprises high-quality solid-state relays for application-specific problem solving and delivers high performance in a width of just 6.1 mm. The wide range of accessories from plug-in cross-connections to end-to-end marking solutions makes it particularly versatile. Thanks to international approvals, they can be used worldwide. Reliable function is ensured by the integrated protective suppressor circuit for inputs and outputs. The wide MICROOPTO portfolio includes a range of solutions for special loads. For example, for inductive loads up to 10 A at 24 V DC or for DC loads up to 300 V. In addition, there are solutions for decoupling 5 V TTL inputs and outputs, for frequencies up to 550 kHz, as well as the single CO contact version for inverting signals.

General ordering data

Version	MICROOPTO, Solid-state relay, Rated control voltage: 12 V DC...28 V DC , Rated switching voltage: 19.6...28.8 V DC, Continuous current: 50 mA, Screw connection
Order No.	8937990000
Type	MOS 12-28VDC 100KHZ
GTIN (EAN)	4032248716227
Qty.	1 pc(s).

MOS 12-28VDC 100KHZ

Weidmüller Interface GmbH & Co. KG

Klingenbergstraße 26

D-32758 Detmold

Germany

www.weidmueller.com

Technical data

Dimensions and weights

Depth	97.8 mm	Depth (inches)	3.85 inch
Height	88.1 mm	Height (inches)	3.468 inch
Width	6.1 mm	Width (inches)	0.24 inch
Net weight	31.81 g		

Temperatures

Storage temperature	-40 °C...80 °C	Operating temperature	-25 °C...60 °C
Humidity	5-95% relative humidity, T _u = 55°C, without condensation		

Probability of failure

MTTF	2,559 a
------	---------

Control side

Rated control voltage	12 V DC...28 V DC	Power rating	≤ 360 mW
Status indicator	Green LED	Protective circuit	Varistor, Reverse polarity protection
Input frequency	100 kHz		

Load side

Rated switching voltage	19.6...28.8 V DC	Continuous current	0.05 A
Rated switching current	50 mA	Load category	LC A
Max. switching voltage, DC	48 V	Pulse load, max. current	0.6 A (20 ms)
Switch-on delay	<200 ns	Switch-off delay	<400 ns
Voltage drop at max. load	≤ 2 V	Leakage current	<1 µA
Short-circuit-proof	No	Protective circuit, load side	Varistor, Reverse polarity protection
Contact type	1 NO contact (Transistor)	max. switching frequency (DC control voltage)	530 kHz
Nominal auxiliary voltage	19.6...28.8 V / max. 8 mA		

General data

Rail	TS 35		
Colour	black		
UL 94 flammability rating	V-0		
UL94 flammability rating component	Component	Housing	
	UL94 flammability rating	V-0	

Insulation coordination

Rated voltage	30 V	Pollution severity	2
Surge voltage category	II	Dielectric strength for control side - load side	350 V _{eff} / 1 min.
Dielectric strength to mounting rail	350 V _{eff} / 1 min.	Impulse withstand voltage	500 V (1,2/50 µ)
Protection degree	IP20		

Further details of approvals / standards

Certificate No. (DNV)	TAE000033E	Certificate no. (cULus)	E141197
-----------------------	------------	-------------------------	---------

Creation date November 26, 2024 12:17:09 PM CET

Catalogue status 26.11.2024 / We reserve the right to make technical changes.

2

MOS 12-28VDC 100KHZ

Weidmüller Interface GmbH & Co. KG

Klingenbergstraße 26

D-32758 Detmold

Germany

www.weidmueller.com

Technical data

Connection data

Wire connection method	Screw connection	Stripping length, rated connection	7 mm
Tightening torque, min.	0.4 Nm	Tightening torque, max.	0.6 Nm
Clamping range, rated connection	2.5 mm ²	Clamping range, min.	0.5 mm ²
Clamping range, max.	4 mm ²	Wire cross-section, solid, min.	0.5 mm ²
Wire cross-section, solid, max.	4 mm ²	Wire connection cross section, finely stranded, min.	0.5 mm ²
Wire connection cross section, finely stranded, max.	2.5 mm ²	Wire connection cross-section, finely stranded with wire-end ferrules DIN 46228/4, min.	0.5 mm ²
Wire connection cross-section, finely stranded with wire-end ferrules DIN 46228/4, max.	1.5 mm ²	Conductor cross-section, flexible, AEH (DIN 46228-1), min.	0.5 mm ²
Conductor cross-section, flexible, AEH (DIN 46228-1), max.	1.5 mm ²	Blade size	0.6 x 3.5 mm

Classifications

ETIM 6.0	EC001504	ETIM 7.0	EC001504
ETIM 8.0	EC001504	ETIM 9.0	EC001504
ECLASS 9.0	27-37-16-04	ECLASS 9.1	27-37-16-04
ECLASS 10.0	27-37-16-04	ECLASS 11.0	27-37-16-04
ECLASS 12.0	27-37-16-04	ECLASS 13.0	27-37-16-04
ECLASS 14.0	27-37-16-04		

Environmental Product Compliance

RoHS Compliance Status	Compliant with exemption
RoHS Exemption (if applicable/known)	7a, 7cl
REACH SVHC	Lead 7439-92-1
SCIP	d32f8e61-6733-45d6-9062-c95f9903aad6

Important note

Product information	The cable lengths must not exceed 30 m.
---------------------	-----------------------------------------

Approvals

Approvals



ROHS	Conform
UL File Number Search	UL Website
Certificate no. (cULus)	E141197

Downloads

Approval/Certificate/Document of Conformity	EU Konformitätserklärung / EU Declaration of Conformity
Engineering Data	CAD data – STEP
User Documentation	Beipackzettel / Package Insert – multilingual
Catalogues	Catalogues in PDF-format
Brochures	

Creation date November 26, 2024 12:17:09 PM CET

Catalogue status 26.11.2024 / We reserve the right to make technical changes.

3

MOS 12-28VDC 100KHZ

Weidmüller Interface GmbH & Co. KG
 Klingenbergstraße 26
 D-32758 Detmold
 Germany

www.weidmueller.com

Drawings

Wiring diagram

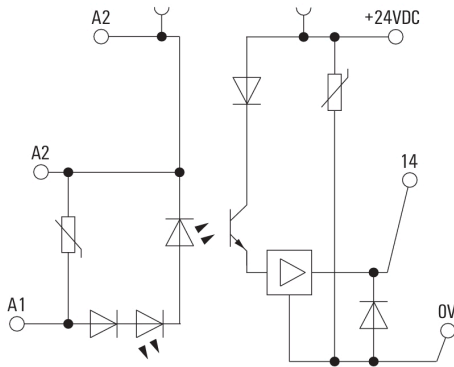

Max. switching frequency is dependent on the duty cycle deviation

MOS 12-28 V DC 100 kHz (switching current 50 mA, ohmic load)

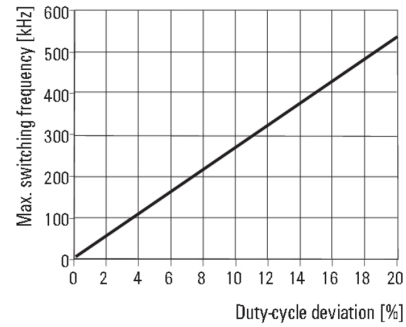

Max. switching frequency depending on the duty-cycle deviation

Dimensional drawing

