

ORDERING INFORMATION

Order code: 62935
 Description: BMH1000/TRITAP/C/CWA/H/K/STD
 UPC: 69549629356

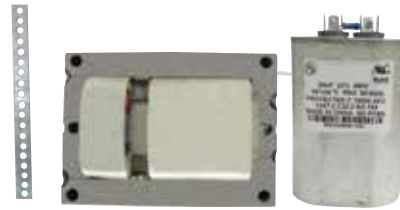

SPECIFICATIONS

Ballast type: Magnetic metal halide
 Ballast style: Core and coil
 Circuit type: CWA
 ANSI code: M47 or H36
 Input voltage (V): 120/277/347
 Input frequency (Hz): 60
 Line volt regulation: 10 %
 Line watt regulation: 10 %
 Insulation class: H (180)

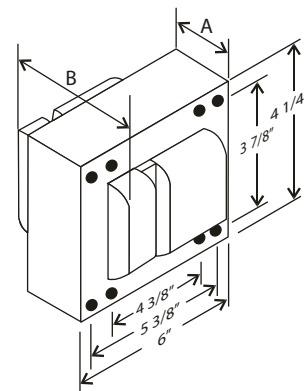

4 1/4" x 6" Core



Input voltage (V)	Operating current (A)	Open circuit current (A)	Starting current (A)	Rated lamp watts (W)	Input watts (W)	OCV (V)	Dropout voltage (V)	UL 1029 code	Fuse rating (A)	Input current (A)	Power factor	Starting temperature
120	8.90	4.95	6.60	1 000	1 100	415	84	E	25	3.30 - 5.10	0.90	-20°F / -30°C
277	3.90	2.30	2.85	1 000	1 100	415	194	E	10	1.40 - 2.15	0.90	-20°F / -30°C
347	3.15	1.80	2.25	1 000	1 100	415	243	D	8	1.10 - 1.70	0.90	-20°F / -30°C

HIGH POTENTIAL TEST (V)

1 minute:	2 000
2 seconds:	2 500
OCV test:	380 - 470
Short circuit:	4.80 - 6.80

BALLAST DIMENSIONS

Dimension A:	3.50"
Dimension B:	5.50"
Lead lengths:	12" - 14"
Weight (lbs) :	23

WIRING DIAGRAM

Ground ballast core

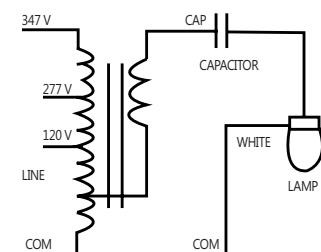

BRACKET

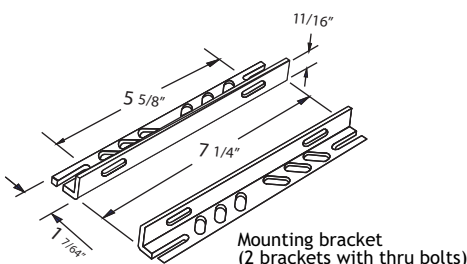

CAPACITOR

