



Main

Range Compatibility	Lexium 32i
Product or Component Type	Servo motor with power stage
Device short name	BMI

Complementary

Maximum mechanical speed	8000 rpm
[Us] rated supply voltage	208...480 V - 15...10 %
Supply voltage limits	208...480 V
Phase	Three phase
Supply frequency	50/60 Hz - 5...5 %
Network frequency limits	47.5...63 Hz
EMC filter	Integrated
Continuous output current	2 A 8 kHz
Output current 3s peak	6 A 400 V 3 s
Continuous stall current	2 A
Continuous stall torque	30.09 lbf.in (3.4 N.m) 208...480 V three phase
Peak stall torque	76.12 Lbf.in (8.6 N.m) 208 V three phase 76.12 Lbf.in (8.6 N.m) 400 V three phase 76.12 lbf.in (8.6 N.m) 480 V three phase
Nominal output power	900 W 400 V three phase 900 W 480 V three phase 450 W 208 V three phase
Nominal torque	25.67 Lbf.in (2.9 N.m) 208 V three phase 23.90 Lbf.in (2.7 N.m) 400 V three phase 20.36 lbf.in (2.3 N.m) 480 V three phase
Nominal speed	3300 rpm 400 V three phase 1600 rpm 208 V three phase 3900 rpm 480 V three phase
Maximum current Irms	12.5 A 400 V, three phase 12.5 A 480 V, three phase 12.5 A 208 V, three phase
Product compatibility	Drive control unit LXM32i CANopen Drive control unit LXM32i EtherCAT
Shaft end	Untapped
Second shaft	Without second shaft end
Shaft diameter	0.55 in (14 mm)
Shaft length	1.18 in (30 mm)
Feedback type	Absolute multiturn SinCos Hiperface
Speed feedback resolution	32768 points/turn x 4096 turns
Holding brake	Without
Mounting Support	International standard flange
Motor flange size	2.76 in (70 mm)

Electrical Connection	Printed circuit board connector
Torque constant	1.41 N.m/A 68 °F (20 °C)
Back emf constant	95.39 V/krpm 68 °F (20 °C)
Number of motor poles	10
Rotor inertia	1.67 kg.cm ²
Stator resistance	7.99 Ohm 68 °F (20 °C)
Stator inductance	25.6 mH 68 °F (20 °C)
Stator electrical time constant	3.2 ms 68 °F (20 °C)
Maximum radial force Fr	730 N 1000 rpm 580 N 2000 rpm 510 N 3000 rpm 460 N 4000 rpm 430 N 5000 rpm 400 N 6000 rpm
Maximum axial force Fa	0.2 x Fr
Type of cooling	Natural convection
Length	11.81 in (300 mm)
Number of motor stacks	3
Centring collar diameter	2.36 in (60 mm)
Centring collar depth	0.10 in (2.5 mm)
Number of mounting holes	4
Mounting holes diameter	0.22 in (5.5 mm)
Circle diameter of the mounting holes	2.95...3.23 in (75...82 mm)
Distance shaft shoulder-flange	0.10 in (2.5 mm)

Environment

IP Degree of Protection	Shaft IP54 Housing IP65
-------------------------	----------------------------

Ordering and shipping details

Category	18287-LEXIUM 32 INTEGRATED DRIVES
Discount Schedule	PC56
GTIN	3606485376349
Returnability	No
Country of origin	DE

Packing Units

Unit Type of Package 1	PCE
Number of Units in Package 1	1
Package 1 Height	10.16 in (25.8 cm)
Package 1 Width	7.87 in (20.0 cm)
Package 1 Length	23.23 in (59.0 cm)
Package 1 Weight	14.33 lb(US) (6.5 kg)
Unit Type of Package 2	P06
Number of Units in Package 2	8
Package 2 Height	30.31 in (77.0 cm)
Package 2 Width	31.50 in (80.0 cm)
Package 2 Length	23.62 in (60.0 cm)
Package 2 Weight	133.38 lb(US) (60.5 kg)

Offer Sustainability

Sustainable offer status	Green Premium product
California proposition 65	WARNING: This product can expose you to chemicals including: Lead and lead compounds, which is known to the State of California to cause cancer and birth defects or other reproductive harm. For more information go to www.P65Warnings.ca.gov
REACH Regulation	REACH Declaration
EU RoHS Directive	Pro-active compliance (Product out of EU RoHS legal scope)
Mercury free	Yes
China RoHS Regulation	China RoHS Declaration
RoHS exemption information	Yes
Environmental Disclosure	Product Environmental Profile
Circularity Profile	End Of Life Information
WEEE	The product must be disposed on European Union markets following specific waste collection and never end up in rubbish bins.
PVC free	Yes

Contractual warranty

Warranty	18 months
----------	-----------

External Dimensions

With Standard Braking Resistor

Mounting type A

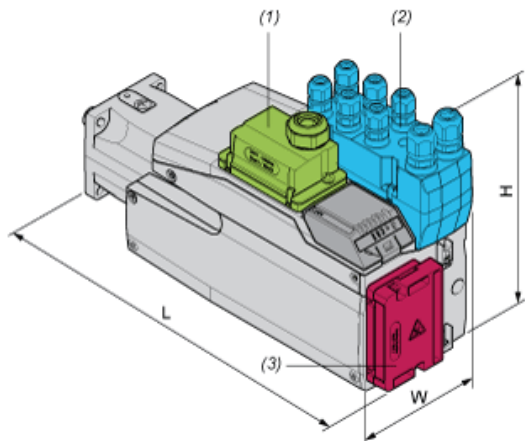

- (1) Module for supply voltage
- (2) I/O module
- (3) Standard braking resistor

Dimensions in mm

W	H	L
99	187	321

Dimensions in in.

W	H	L
3,90	7,36	12,64

Mounting type B



- (1) Module for supply voltage
- (2) I/O module
- (3) Standard braking resistor

Dimensions in mm

W	H	L
99	138,5	370

Dimensions in in.

W	H	L
3,90	5,45	14,57

With External Braking Resistor

Mounting type C



- (1) Module for supply voltage
- (2) I/O module
- (4) External braking resistor

Dimensions in mm

W	H	L
99	187	333

Dimensions in in.

W	H	L
3,90	7,36	13,11

Mounting type D



- (1) Module for supply voltage
- (2) I/O module
- (4) External braking resistor

Dimensions in mm

W	H	L
99	160	370

Dimensions in in.

W	H	L
3,90	6,3	14,57

Mounting type E



- (1) Module for supply voltage
- (2) I/O module
- (4) External braking resistor

Dimensions in mm

W	H	L
99	187	360

Dimensions in in.

W	H	L
3,90	7,36	14,17

Mounting type F



- (1) Module for supply voltage
- (2) I/O module
- (4) External braking resistor

Dimensions in mm

W	H	L
99	180	370

Dimensions in in.

W	H	L
3,90	7,09	14,57

Performance Curves

Torque/Speed Curves with 208 V Three Phases Supply Voltage



- (X) Speed (rpm)
- (Y) Torque (N.m)
- (1) Motor peak
- (2) Drive peak
- (3) Drive cont
- (4) Motor cont
- (5) Operating point

		Power	At Speed	With Torque
max. Peak Power	■	1138 W	1360 rpm	7.99 N.m
max Cont. Power (Drive)	●	564 W	1840 rpm	2.93 N.m

Performance Curves

Torque/Speed Curves with 400 V Three Phases Supply Voltage



- (X) Speed (rpm)
- (Y) Torque (N.m)
- (1) Motor peak
- (2) Drive peak
- (3) Drive cont
- (4) Motor cont
- (5) Operating point

		Power	At Speed	With Torque
max. Peak Power	■	2390 W	2960 rpm	7.71 N.m
max Cont. Power (Drive)	●	895 W	3760 rpm	2.27 N.m

Performance Curves

Torque/Speed Curves with 480 V Three Phases Supply Voltage

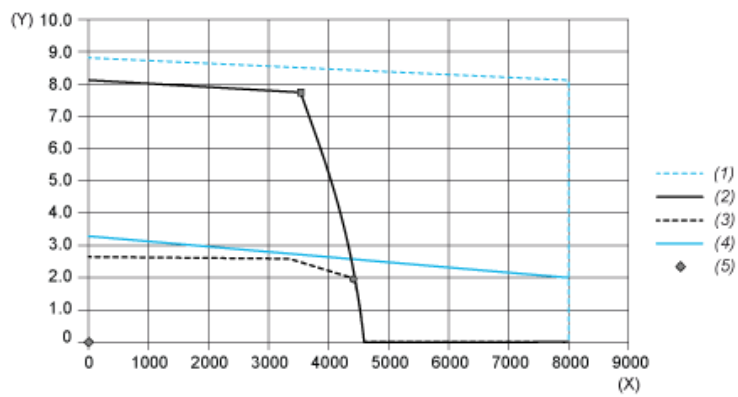

- (X) Speed (rpm)
 (Y) Torque (N.m)
 (1) Motor peak
 (2) Drive peak
 (3) Drive cont
 (4) Motor cont
 (5) Operating point

		Power	At Speed	With Torque
max. Peak Power	■	2915 W	3600 rpm	7.73 N.m
max Cont. Power (Drive)	●	945 W	4560 rpm	1.98 N.m