

# Heavy Duty Industrial

# Silver Line

All Silver Line HD industrial fans are complete with corrosion resistant epoxy-coated metal blades.

**save**

*up to*  
**50%** of your cooling cost  
**30%** of your heating cost



**new**  
**heavy duty**  
**CAST YOKE**

## Silver features

- Downrod diameter 7/8" eg. E962-36
- Corrosion-resistant epoxy prime and finish coat on all metal housing & blades  
The aerodynamically curved-tip blade results in maximum air delivery.
- All metal, no plastic.
- Permanent lubricated sealed TPI ball bearings.
- Totally enclosed impedance protected motor.
- Non-polar, weatherproof encapsulated, extra heavy-duty capacitor.
- Use solid state infinite speed motor controls or church quiet control. (WC103)
- Heavy cast yoke for easy infield downrod change.
- Customized downrod lengths over 36" available.  
Also 16' cord with plug part# Cord-Wh16.

Model	60F-9	60F-7
Safety Cable	60"	60"
Cord/Lead Wire	60"	60"
Diameter Sweep	56"	56"
CFM	27,500	27,500
Area (sq.ft.)	1,800	1,800
Velocity (ft/m)	600	600
Volts	120	120
Amps	0.70	0.70
Watts	75	75
RPM (max)	320	320
Wiring	3+ground	plug-in
Airflow	up & down	down only
Weight	13 lbs	13 lbs

## Silver



*ideal*

for heavy duty industrial use

heavy duty motor application  
 more airflow - higher RPM's  
 higher performance heavy duty fan

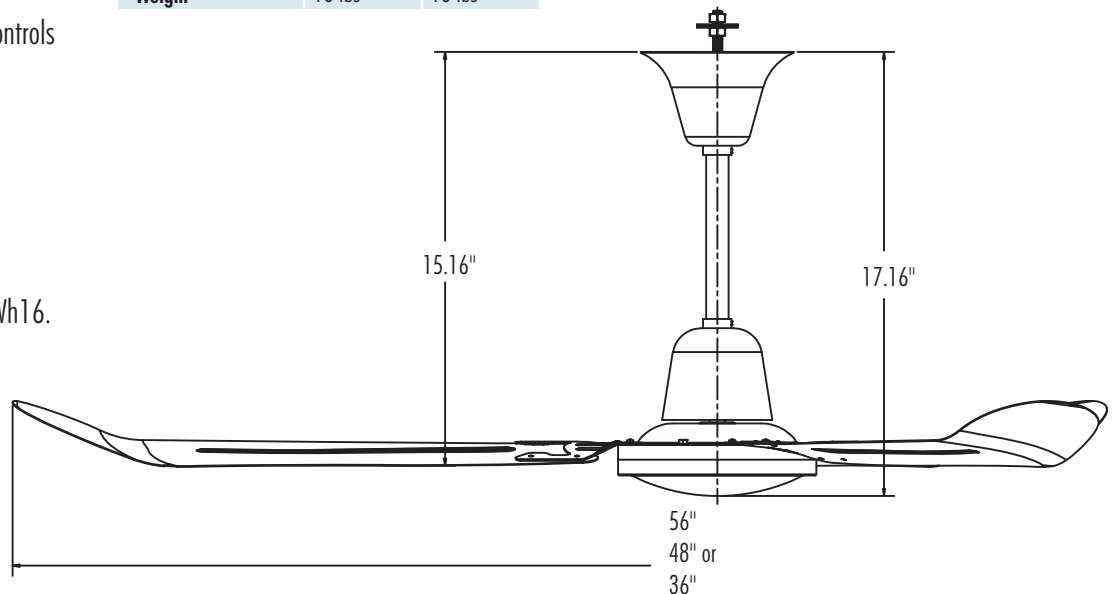

Silver Line features curve tip blades.