

CI-355

v3

360° Passive Infrared • Line Voltage Occupancy Sensor with Light Level feature



Installation Instructions

SPECIFICATIONS

Voltages.....	120//230/277/347VAC, 50/60Hz
Load Ratings	
@120VAC	0-800W Ballast/Tungsten/LED
@230VAC (Single Phase).....	0-1200W Ballast/LED
@277VAC	0-1200W Ballast/LED
@347VAC	0-1500W Ballast/LED
Operating Temperature	32° to 131°F (0° to 55°C)
Light Level One-Step Adjustment	10FC-300FC
Time Delay Adjustment.....	30 seconds to 30 minutes
Walk-Through Mode	3 minutes if no activity after 30 sec.
Test Mode.....	5 sec. upon DIP switch reset
PIR Coverage	
Model CI-355.....	up to 1200ft ²
Model CI-355-1	up to 500ft ²
Sensitivity Adjustment	High or Low (DIP switch)

WattStopper®

UNIT DESCRIPTION

The WattStopper CI-355 360° passive infrared (PIR) occupancy sensors turn lighting systems on and off based on occupancy and ambient light levels. The light level feature can be used to keep lights from turning on if the ambient light level is sufficient.

The sensors can be configured to turn lighting on, and hold it on as long as the sensor detects occupancy. After no movement is detected for a user specified time (30 seconds to 30 minutes) the lights are switched off. A "walk-through" mode can turn lights off after only 3 minutes, if no activity is detected after 30 seconds of an occupancy detection.

The CI-355 operates on 120VAC, 230VAC (1Ø), 277VAC, or 347VAC.

COVERAGE PATTERN

The CI-355 provides a 360° coverage pattern. Two lens patterns are available. The CI-355 provides up to 1200 square feet of coverage and the CI-355-1 provides up to 500 square feet of coverage. The coverage shown represents walking motion at a mounting height of 8 feet. For building spaces with lower levels of activity or with obstacles and barriers, coverage size may decrease.

Drawings not to scale

Side View

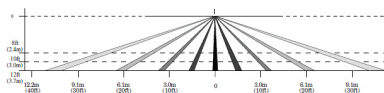

CI-355 Coverage Pattern
(standard lens)

Top View @ 8ft

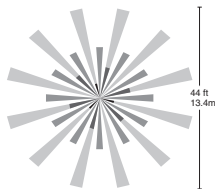

Side View

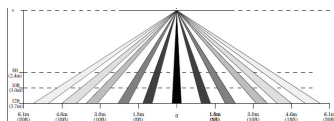

CI-355-1 Coverage Pattern
(high density, reduced range lens)

Top View @ 8ft

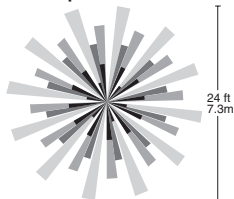

PLACEMENT GUIDELINES

Depending upon obstacles such as furniture or partitions, the area of coverage may be less or more than the sensing distances shown in the coverage pattern. This must be considered when planning the number of sensors and their placement. It is also recommended to place the sensor 4 to 6 feet away from air supply ducts as rapid air currents or the differences in temperatures may cause false activations.

Mount the sensor to the ceiling. The CI-355 is designed for a ceiling height of about 8-12 feet. Mounting above or below this range will significantly affect the coverage patterns. Be aware that as you decrease the mounting height, you decrease the range and increase the sensitivity to smaller motions. Conversely, when you increase the height, you increase the range and decrease the sensitivity to smaller motions. At heights of more than 12-14 feet, you may start to significantly reduce sensitivity. As a general rule, each occupant should be able to clearly view the sensor.

Often the best location to install a CI-355 in a closed office is off-center. Avoid placing a sensor directly in line with an open door through which it has a clear view out, as the sensor may detect people walking by.

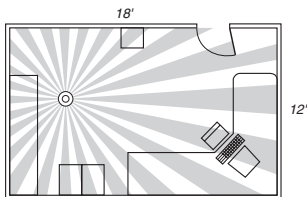

Masking the PIR Lens: Opaque adhesive tape is supplied so that sections of the PIR lens can be masked. This restricts the sensor's view and allows you to eliminate PIR coverage in unwanted areas such as hallways outside of the desired coverage area. Since masking removes bands of coverage, remember to take this into account when troubleshooting coverage problems.

Optimizing Coverage: To get complete coverage in an open office area, install multiple sensors so that there is an overlap with each adjacent sensor's coverage area.

For open office areas with partitions it is best to place sensors over intersection of four workstations.

For large areas of coverage use multiple sensors.

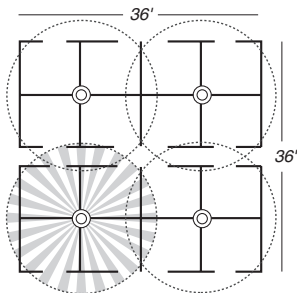

WIRING DIRECTIONS



CAUTION



**TURN POWER OFF AT THE CIRCUIT BREAKER
BEFORE INSTALLING SENSORS.**

#12 to #16 AWG

Strip Gauge

Cu Wire Only

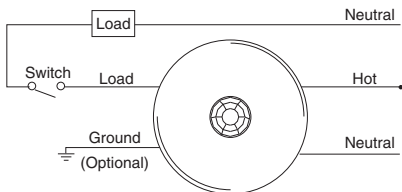

Single Sensor, Single Load

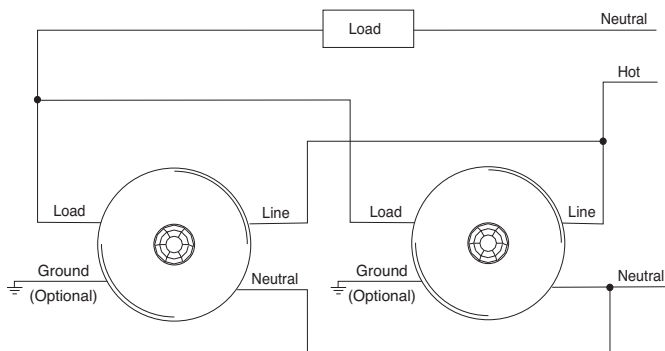

Multiple Sensors Connected in Parallel

WARNING: This application does not allow for Load to increase.

Visit our website for FAQs: www.wattstopper.com

MOUNTING THE SENSOR

Using a 4-Inch Square Junction Box with Double-Gang Mudring

1. Pull the high voltage wires into the J-Box through the conduit knockout.
2. Connect the high voltage wires to the appropriate terminals on the sensor.
3. Align the sensor in the J-Box so that the mudring mounting screw tabs on the box match the mudring mounting holes on the sensor's rear housing.
4. Use two machine screws (included with the sensor) to attach the sensor to the mounting tabs on the J-Box.
5. Snap the front cover onto the sensor.

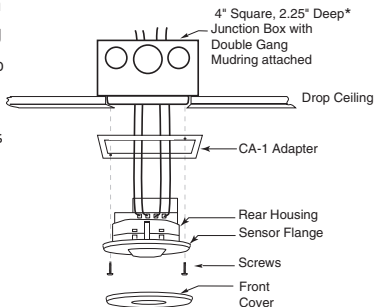

Mounting to a 4" Square Junction Box with Mudring

Using an Octagonal Junction Box

1. Pull the high voltage wires into the J-Box through the conduit knockout.
2. Connect the high voltage wires to the appropriate terminals on the sensor.
3. Align the sensor in the J-Box so that the mounting screw tabs on the box match the key holes on the sensor's rear housing.
4. Use two machine screws (included with the J-Box) to attach the sensor to the mounting tabs on the J-Box.
5. Snap the front cover onto the sensor.

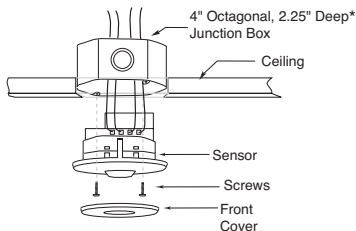

Mounting to an Octagonal Junction Box

*** The Junction Box must be at least 2.25" deep. If it is not, an extension ring is required.**

SENSOR ADJUSTMENT

This unit is pre-set for basic operation as described in this guide. Adjustment is optional.

The sensors are factory preset to allow for quick installation in most applications. Verification of proper wiring or coverage, or customizing the sensor's settings can be done using the following procedures. To make adjustments, open the Front Cover by pulling on the cover tab.

There is a 30 second warm-up period when power is first applied.

Before making adjustments, make sure the office furniture is installed, lighting circuits are turned on, and the HVAC systems are in the overridden/on position. VAV systems should be set to their highest airflow. Set the DIP switches to the desired settings. See "DIP Switch Setting", next page.

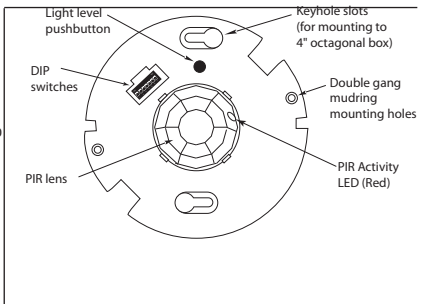

To Test Occupancy Sensors

1. Ensure the Time Delay is set for **Test Mode*** using the "Test Mode/20 minutes" setting. (DIP switches 1,2, & 3 are OFF).
2. Ensure that the Light Level is at default (maximum). See the Light Level Feature section of this document for instructions.
3. Remain still. The red LED should not flash. The lights should turn off after 5 seconds. (If not, see "Troubleshooting.")
4. Move about the coverage area. The lights should come on.

When testing and adjustment is complete, reset DIP switches and Light Level to the desired settings, and replace the cover on the sensor.

* Test Mode is a temporary state that starts when you first set the sensor's DIP switches for the "Test Mode/20 minutes" (switches 1, 2, 3 OFF). If you need to invoke the Test Mode and the DIP switches are already set for Test Mode/20 minutes, toggle DIP switch 1 ON then back to the OFF position. This provides a 10 minute test period. During the test period, the Time Delay is only 5 seconds.

LIGHT LEVEL FEATURE

The Light Level feature holds lights off upon initial occupancy if adequate ambient light exists. It will not turn the lights off if they are on. The default setting is for maximum, meaning that even the brightest ambient light will not hold the lights off.

Notes on Functionality

- Avoid mounting the sensor close to lighting fixtures
- Adjust during daylight hours when ambient light in the area is at desired level.
- Light Level cannot be enabled while Test Mode is active. Either wait for Test Mode to expire or select any of the other Time Delay settings before enabling the Light Level feature.
- The red LED will flash periodically to indicate the sensor has Light Level enabled.
- Light Level settings are only saved in the event of a power loss. Disabling Light Level and then reenabling it will not return it to previous settings.
- If Test Mode is enabled after Light Level has been set, Light Level functionality will cease to function throughout the duration of Test Mode. When Test Mode period expires, the Light Level functionality will resume, even if the Dip Switches remain set to Test Mode.

Setting Light Level

1. Make sure Test Mode is not active.
2. Toggle the state of the sensor, by briefly pressing the Light Level button, to include or exclude the lighting load from the light level calibration. Open the Front Cover and locate the Light Level pushbutton. See Sensor Adjustment.
3. Press and hold the Light Level button between 2s and 5s. The red LED will be ON showing 2s is reached and then be OFF showing 5s has passed*. The sensor enters setup mode, as indicated by the rapidly flashing LED. The LED will flash throughout the setup process. Occupancy indications from the LED is disabled during setup.
4. Move away from the sensor to avoid interference with light level detection. The sensor measures the light level for a 10 second period, then averages the readings and automatically sets the level that will be used as the new setting. The sensor will hold lights off when the ambient light exceeds this setting.
5. When the LED stops flashing, replace the Front Cover.

*Disabling Light Level

Pressing the Light Level button for 5 seconds or more resets the light to default (maximum).

The LED will be ON while the button is pressed, and then OFF once five seconds have passed. The LED flashes rapidly for 10 seconds after the setting has changed.

DIP SWITCH SETTING

The CI-355 has 6 DIP switches under the cover.

Time Delay: Switches 1, 2, 3

The sensor will hold the lights ON as long as occupancy is detected. The time delay countdown starts when no motion is detected. After no motion is detected for the length of the time delay, the sensor will turn the lights OFF.

Walk Through: Switch 4

Walk-through mode turns the lights OFF three minutes after the area is initially occupied, if no motion is detected after the first 30 seconds. If motion continues beyond the first 30 seconds, the selected time delay applies.

Sensitivity: Switch 5

- Minimum forces a reduced detection range for the PIR.
- Maximum forces the sensitivity to the maximum coverage area. This setting is constantly updated.

Service: Switch 6

To override all sensor functions, set DIP switch 6 to the ON position. The red LED will come on and stay on for the duration of the override.

This bypasses the light level and occupancy detection control functions of the sensor.



Feature	Switch#
Time Delay	1 2 3
Test Mode/20 min	↓ ↓ ↓
30 seconds	↓ ↓ ↑
5 minutes	↑ ↓ ↓
10 minutes	↓ ↓ ↑
15 minutes	↑ ↓ ↓
20 minutes	↑ ↓ ↑ ◀
25 minutes	↑ ↑ ↓
30 minutes	↑ ↑ ↑
Walk-Through	4
Enabled	↑
Disabled	↓ ◀
PIR Sensitivity	5
Minimum	↑
Maximum	↓ ◀
Service	6
Service	↑
Normal	↓ ◀

◀ = Factory Setting

↑ = ON

↓ = OFF

TROUBLESHOOTING

 **CAUTION** 
**TURN POWER OFF AT THE CIRCUIT BREAKER
BEFORE WORKING WITH OR NEAR HIGH VOLTAGE.**

For any unexpected operation

1. Check DIP switch settings.
2. Make sure the switches are set according to the defined settings in the DIP Switch Setting chart.

Lights do not turn ON with occupancy, and the following condition exists:

Red LED does not flash:

1. When power is initially applied to the sensor, there is a warm-up period of up to 30 seconds before the red LED is active.
2. Check that the circuit breaker has been turned back on.
3. Check all sensor wire connections.
4. Make sure that PIR Sensitivity is set to 100% (DIP switch #5 set to OFF).
5. If it still does not flash, call 800.879.8585 for Technical Support.

LED flashes:

- Check all sensor wire connections.

Lights do not turn OFF automatically:

1. The sensor technology (PIR) may be experiencing activations from outside the controlled area or from some type of interference (see "Unwanted Sensor Activations" below).
2. Check all sensor wire connections.
3. Turn sensitivity and time delay to minimum and allow the sensor to time out. If the lights turn off, the sensor is working properly (see number 1, above, and "Sensor Adjustment" for readjustment of sensor).

Unwanted Sensor Activations (LED flashes):

Improper sensor location or inadequate masking may be causing detection outside of desired coverage area.

1. The PIR sensitivity may be set too high.
2. Sensor located too close to HVAC or VAV vents with heavy air flow.
3. Check if Light Level is enabled.
 - If occupancy indicator LED blinks every few seconds, sensor is using Light Level feature.

Call 800.879.8585 for Technical Support

- If Light Level functionality is not desired, press and hold for 5 seconds to return sensor to the default setting (maximum).

Possible solutions

1. Mask the lens to reduce PIR coverage (see “Masking the PIR Lens”, under “Placement Guidelines”).
2. Set Dip switch 5 to Minimum (ON) and see if activations stop.
3. Relocate the sensor.

ORDERING INFORMATION

Catalog #	Description
CI-355	Passive Infrared Occupancy Sensor, Line Voltage, 360° lens, up to 1200 square ft., with light level sensor
CI-355-1	Passive Infrared Occupancy Sensor, Line Voltage, 360° high density/reduced range lens, up to 500 square ft., with light level sensor
CA-1	Cosmetic adapter for ceiling installation with 4" square j-box or Wiremold #V5752 box

All sensors are white.

WARRANTY INFORMATION

WattStopper warrants its products to be free of defects in materials and workmanship for a period of five (5) years. There are no obligations or liabilities on the part of WattStopper for consequential damages arising out of or in connection with the use or performance of this product or other indirect damages with respect to loss of property, revenue, or profit, or cost of removal, installation or reinstallation.

WattStopper®

2800 De La Cruz Boulevard, Santa Clara, CA 95050
 800.879.8585 • www.wattstopper.com
 17044r4 11/2014

Please
Recycle

