



Main

Range of Product	Harmony GTU
Product or Component Type	Flat screen
Terminal type	Touchscreen display
[Us] rated supply voltage	12...24 V DC power supply
Supply voltage limits	10.8...28.8 V
Power Consumption in W	21 W
Inrush current	30 A

Complementary

Integrated connection type	USB 2.0 type A USB 2.0 type mini B
Touchscreen resolution	1024 x 1024
Pixel resolution	1024 x 600
Display size	12.1 inch
Aspect ratio	4:3
Display type	Colour TFT LCD
Display Resolution	1024 x 768 pixels XGA
Display colour	16 million colours
Backlight lifespan	50000 hours
Touch panel	Multi touch analogue resistive
Function Available	Brightness sensor
Type of cooling	Natural convection
Type of Installation	Indoor installation
Cut-out dimensions	301.5 (+ 1/- 0) x 227.5 (+ 1/- 0) mm
Width	12.40 in (315 mm)
Height	9.49 in (241 mm)
Depth	2.64 in (67 mm)
Net Weight	6.61 lb(US) (3 kg)

Environment

IP degree of protection	Front panel IP66 Front panel IP67
NEMA degree of protection	NEMA 4X front panel
Standards	UL 508 ANSI/ISA 12-12-01 Class I division 2 CSA C22.2 No 213 CSA C22.2 No 142 IEC 61132-2
Product certifications	CE[RETURN]UKCA[RETURN]UKEX
Ambient air temperature for operation	32...140 °F (0...60 °C) IEC 61131-2
Ambient air temperature for storage	-4...140 °F (-20...60 °C)
Relative Humidity	10...90 % non-condensing
Operating altitude	6561.68 ft (2000 m)
Vibration resistance	3.5 mm constant amplitude 5...9 Hz) IEC 61131-2 9.8 m/s ² 9...150 Hz) IEC 61131-2

Shock resistance	147 m/s ² IEC 61131-2
Electromagnetic compatibility	Electrostatic discharge immunity test level 3 conforming to IEC 61000-4-2

Ordering and shipping details

Category	22567-MAGELIS HMI GTU
Discount Schedule	MC2
GTIN	3606480687242
Returnability	Yes
Country of origin	CN

Packing Units

Unit Type of Package 1	PCE
Number of Units in Package 1	1
Package 1 Height	7.32 in (18.6 cm)
Package 1 Width	12.99 in (33 cm)
Package 1 Length	16.93 in (43 cm)
Package 1 Weight	10.58 lb(US) (4.8 kg)
Unit Type of Package 2	CAR
Number of Units in Package 2	2
Package 2 Height	15.75 in (40 cm)
Package 2 Width	13.39 in (34 cm)
Package 2 Length	17.32 in (44 cm)
Package 2 Weight	22.05 lb(US) (10 kg)
Unit Type of Package 3	P12
Number of Units in Package 3	10
Package 3 Height	21.85 in (55.5 cm)
Package 3 Width	31.50 in (80 cm)
Package 3 Length	47.24 in (120 cm)
Package 3 Weight	106.53 lb(US) (48.32 kg)

Offer Sustainability

Sustainable offer status	Green Premium product
California proposition 65	WARNING: This product can expose you to chemicals including: Lead and lead compounds, which is known to the State of California to cause cancer and birth defects or other reproductive harm. For more information go to www.P65Warnings.ca.gov
REACH Regulation	REACH Declaration
EU RoHS Directive	Pro-active compliance (Product out of EU RoHS legal scope)
Mercury free	Yes
China RoHS Regulation	China RoHS Declaration
RoHS exemption information	Yes
Environmental Disclosure	Product Environmental Profile
Circularity Profile	End Of Life Information
WEEE	The product must be disposed on European Union markets following specific waste collection and never end up in rubbish bins.

Contractual warranty

Warranty	18 months
----------	-----------

External Dimensions

Display Unit with Box Module

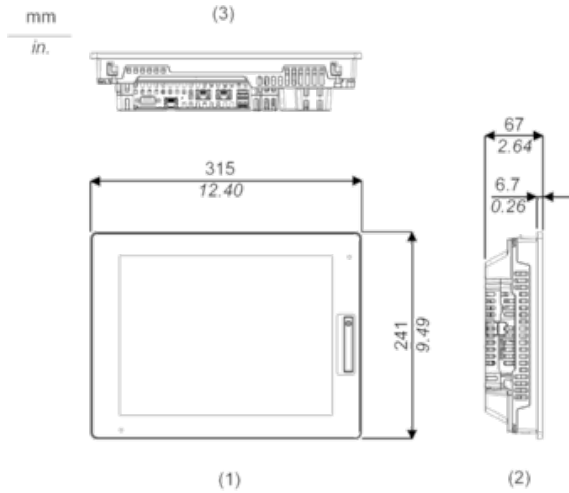

- 1 Front
- 2 Left
- 3 Bottom

Installation with Installation Fasteners and Dimensions with Cables

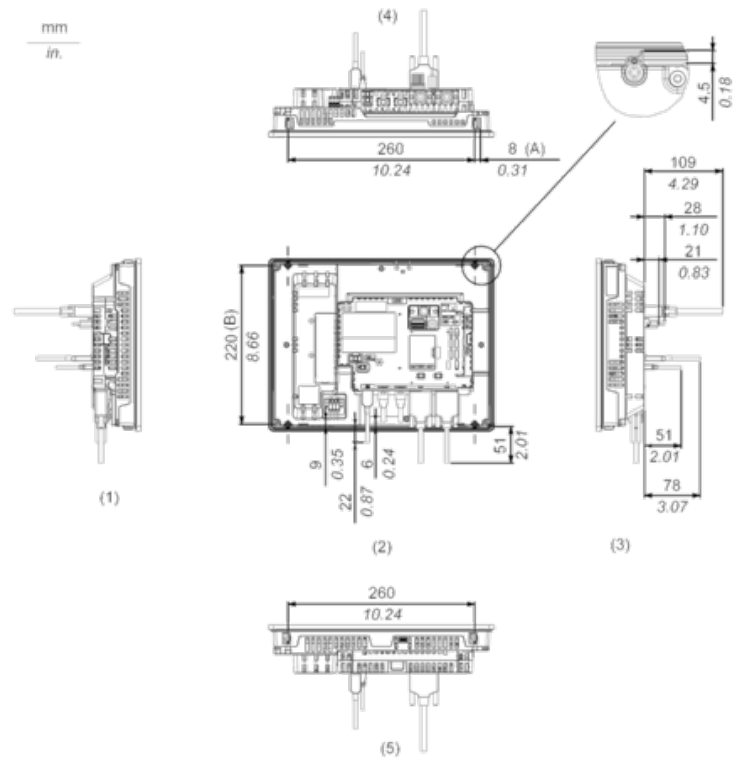

- (A) Rotation area of the fastener
- (B) Pitch of the center of installation fastner screws

- 1 Right
- 2 Front
- 3 Left
- 4 Bottom

Mounting

Panel Cut Dimensions

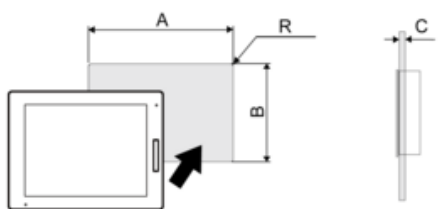

Dimensions in mm

A	B	C	R
301.5 (+1/-0)	227.5 (+1/-0)	1.6...5	3 max.

Dimensions in in.

A	B	C	R
11.87 (+0.04/-0)	8.96 (+0.04/-0)	0.06...0.2	0.12 max.

Installation Requirements

Mounting Angle

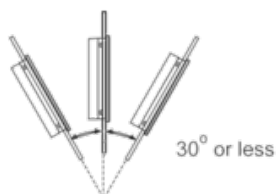

When installing this product in a slanted position with an incline more than 30°, the ambient temperature must not exceed 40 °C (104 °F). You may need to use forced air cooling (fan, A/C) to ensure the ambient operating temperature is 40 °C or less (104 °F or less).

Clearance

