

SCREW:	MATERIAL:	TOLERANCES-UNLESS OTHERWISE SPECIFIED 2 PL. DEC. ±.015 TRUE C.L. ±.015 3 PL. DEC. ±.015 ANGLES ±1		DWG. NO. M2813-05	
CAT. NO.: SPAR-250	PLATING:	DRAWN BY: NN	SCALE: 1/2	SHEET 1 OF 1	
MASS:	MARKING:	DATE: 4/24/2008	SIZE: A		
SURFACE AREA: ²		CELL:	REV.	DESCRIPTION	
STUFFER SHT:					

Cat #: SPAR-250

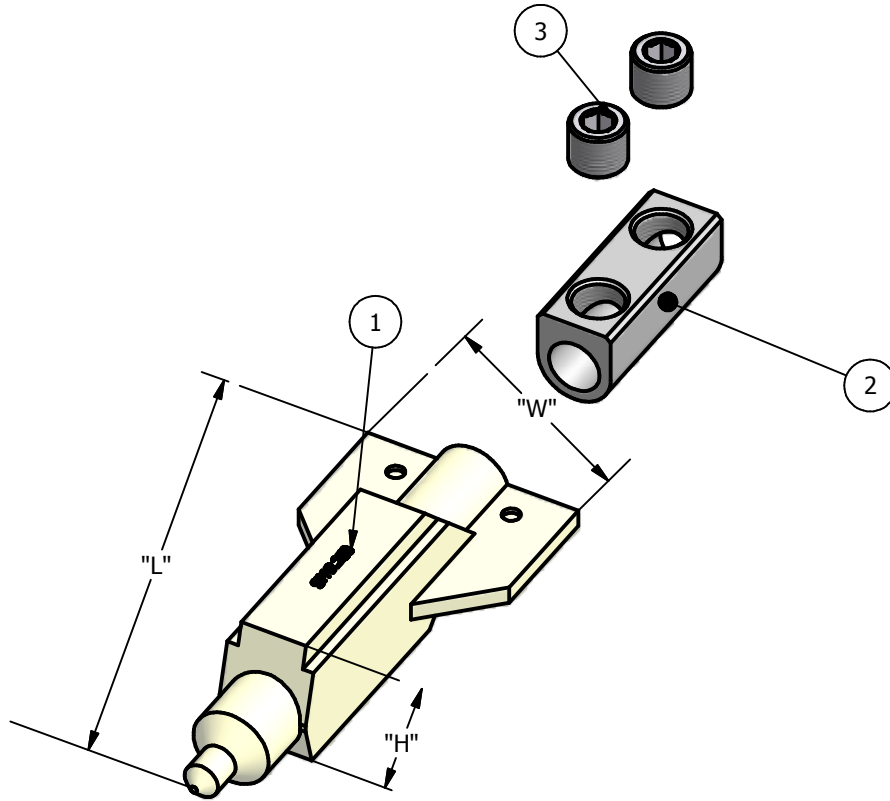

ITEM	"L"	"H"	"W"
1	5.67	1.431	2.53

Parts List			
ITEM	QTY	PART NUMBER	DESCRIPTION
1	1	R1809C01A	COVER WITH HOLES
2	1	D8814C22T	SPAR-250 CONNECTOR
3	2	E0941C00T	SCREWS
4	1	R1689C00A	WIRE TIE
5	1	CBR1426	BAG SIZE