

Raychem AMC-1A

AMBIENT-SENSING THERMOSTAT FOR NONHAZARDOUS LOCATIONS INSTALLATION INSTRUCTIONS

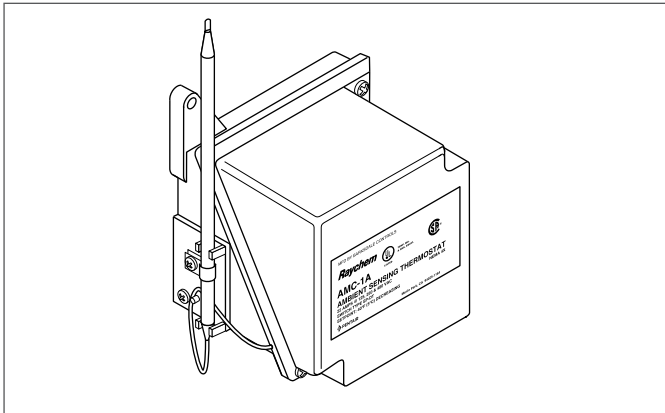

DESCRIPTION

The AMC-1A thermostat is designed for controlling freeze protection heat-tracing systems in nonhazardous locations. The thermostat responds to ambient temperature changes. The AMC-1A can be used to control a heat-tracing circuit directly (see Figure 1 on back page) or it can be used to control a contactor coil (see Figure 2).

APPROVALS



SPECIFICATIONS

Enclosure	NEMA 4X, polyurethane-coated cast-aluminum housing, stainless-steel hardware
Entries	One 3/4 in. NPT conduit hub
Set point range	15°F to 140°F (-9°C to 60°C)
Sensor exposure limits	-40°F to 160°F (-40°C to 71°C)
Housing exposure limits	-40°F to 160°F (-40°C to 71°C)
Switch	SPDT
Electrical rating	22 A at 125/250/480 Vac
Accuracy	±6°F (±3.3°C)
Deadband	2°F to 12°F (1.1°C to 6.7°C) above actuation temperature
Set point repeatability	±3°F (±1.7°C)
Sensor type	Fixed fluid-filled (silicone) bulb and capillary
Sensor material	300 series stainless steel
Connection	Screw terminals, 10-14 AWG (2-5 mm ²) terminals

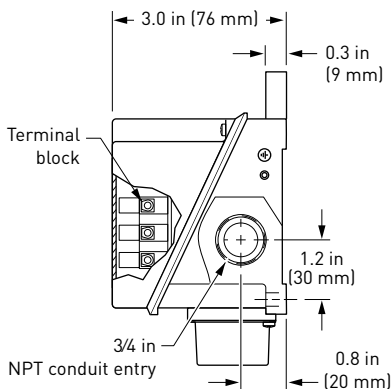
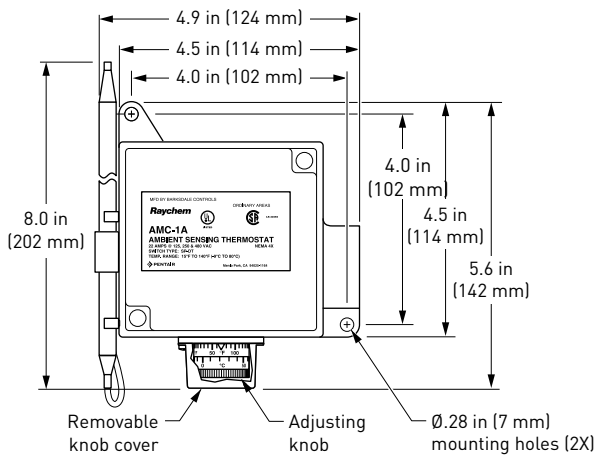

WARNING:

This component is an electrical device. It must be installed correctly to ensure proper operation and to prevent shock or fire. Read these important warnings and carefully follow all the installation instructions.

Component approvals and performance are based on the use of specified parts only. Do not use substitute parts or vinyl electrical tape to make connections.

INSTALLING THE THERMOSTAT

1. Verify that the thermostat is suitable for the area where it is to be installed.
2. Check the line voltage and the heat-tracing load to ensure that the thermostat ratings are not exceeded.
3. Mount the unit in a position that prevents condensation from draining into the enclosure from the connecting conduit (see diagram above).

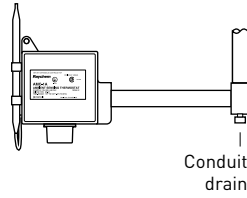

POSITIONING

4. Mount ambient-sensing units in the area exposed to the coldest temperature and the most wind. Do not mount on the side of a warm building or in a location that is exposed to warm air currents or direct sun light.

SETTING AND ADJUSTING

5. Set the thermostat dial to the desired temperature and finish wiring.

WIRING

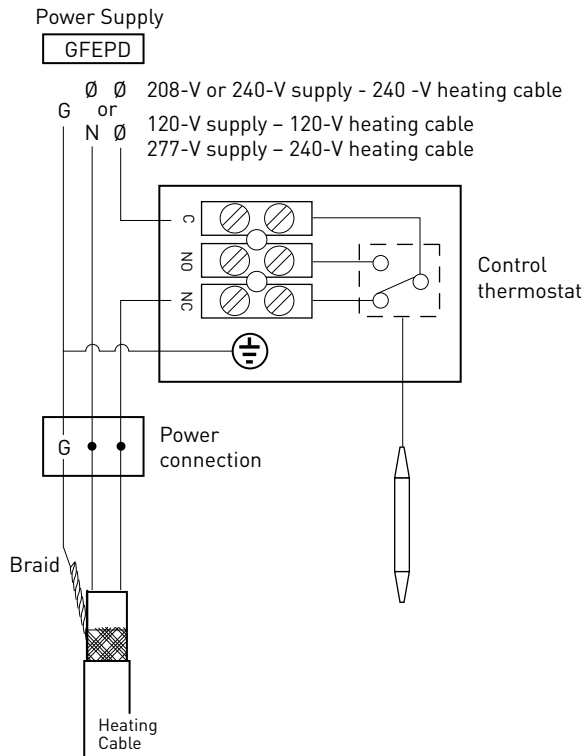

Figure 1. Heat-tracing control

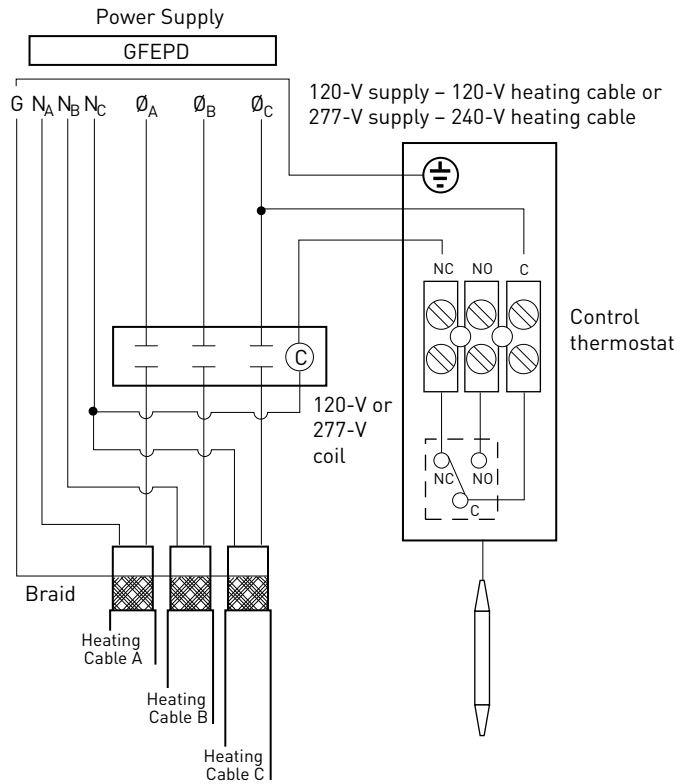

Figure 2. Controlling a contactor

For switching heat-tracing loads greater than 22 A or switching multiple heat-tracing circuits.



WWW.PENTAIRTHERMAL.COM

NORTH AMERICA

Tel: +1.800.545.6258
 Fax: +1.800.527.5703
 Tel: +1.650.216.1526
 Fax: +1.650.474.7711
 thermal.info@pentair.com

EUROPE, MIDDLE EAST, AFRICA

Tel: +32.16.213.511
 Fax: +32.16.213.603
 thermal.info@pentair.com

ASIA PACIFIC

Tel: +86.21.2412.1688
 Fax: +86.21.5426.2937
 cn.thermal.info@pentair.com

LATIN AMERICA

Tel: +1.713.868.4800
 Fax: +1.713.868.2333
 thermal.info@pentair.com

Pentair and AMC are owned by Pentair or its global affiliates. All other trademarks are the property of their respective owners. Pentair reserves the right to change specifications without prior notice.