



FEDERAL SIGNAL
Safety and Security Systems / Industrial
Advancing security and well-being.

Siren Models A & L



Installation and Maintenance Manual

INSTALLATION INSTRUCTIONS FOR FEDERAL SIGNAL SIREN MODELS A & L

I. INSTALLATION

WARNING

Failure to follow all safety precautions and instructions may result in property damage, serious injury, or death to you or others.

SAFETY MESSAGE TO INSTALLERS

Peoples lives depend on your safe installation of our products. It is important to follow all instructions shipped with the products.

This device is to be installed by a trained electrician who is thoroughly familiar with the applicable National Electric Code and will follow the NEC guidelines as well as local codes.

The selection of the mounting location for the device, its controls and the routing of the wiring are to be accomplished under the direction of the Facilities Engineer and the Safety Engineer. In addition, listed below are some other important safety instructions and precautions you should follow:

- Read and understand all instructions before installing or operating this equipment.
- Do not connect this unit to the system when power is on.
- Optimum sound distribution will be severely reduced if any objects are in front of the siren. You should ensure that the front of the siren is clear of any obstructions.
- All effective signaling sirens produce loud sounds, which may cause, in certain situations, permanent hearing loss. They should be installed far enough away from potential listeners to limit their exposure while still maintaining their effectiveness. The OSHA Code of Federal Regulations 1910.95 provides guidelines which may be used regarding permissible noise exposure levels.
- After installation, ensure that all mounting bolts are properly tightened.
- After installation, test the emergency warning system to ensure proper operation.
- Show these instructions to your Safety Engineer and then file them in a safe place and refer to them when maintaining and/or reinstalling the unit.
- Establish a procedure to routinely check the signaling system for proper activation and operation.

A. GENERAL

The Models A and L sirens are intended for general signaling applications. They have NEMA 3R enclosures which are suitable for indoor or outdoor use, providing a degree of protection from rain, sleet and damage from external ice formation. The Model A is intended to operate on 120 volts AC or DC. The 120 volt and 240 volt Model L sirens are also intended to operate on AC or DC. The Model A siren is Underwriters Laboratories Listed as an audible signal (File E4813) for use in USA (Category UCST) or Canada (Category UCST7) and is also CSA Certified for use in Canada (Class 4812 04).

B. UNPACKING

After unpacking the unit, examine it for damage that may have occurred in transit. If the equipment has been damaged, do not attempt to install or operate it, file a claim immediately with the carrier stating the extent of the damage. Carefully check all envelopes, shipping labels and tags before removing or destroying them.

C. SIRENS

Models A-120, L-120 and L-240 sirens are intended to be mounted to a rigid surface. Securely attach siren to the mounting surface by using bolts and washers (user supplied) through the mounting frame. (After the siren is securely attached to the surface, loosen the hex nuts at the sides of the siren and adjust the unit to the desired position. Retighten the hex nuts.

NOTE

Ensure that nothing obstructs the siren projector.

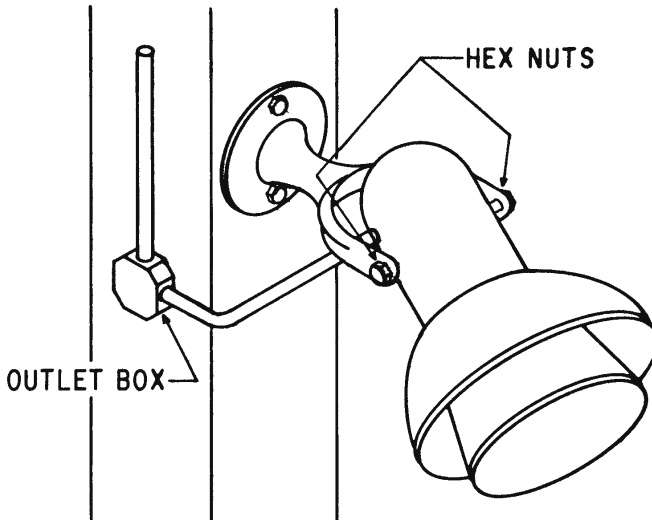

D. ELECTRICAL CONNECTIONS

WARNING

Do not connect if supply wires are energized.

NOTE

CONNECTION OF SIREN'S POWER LEADS TO FIELD WIRING MUST ONLY BE MADE IN A SUITABLE ELECTRICAL BOX SUPPLIED BY THE INSTALLER!

The Model A and L sirens are provided with a 1/2-inch threaded conduit opening and 18-inch field wiring leads. The user supplied electrical box should be mounted as close as possible to the siren using suitable flexible conduit for connecting them.

1. When the Model A siren is to be connected to AC power, its black lead should be connected to the phase lead, its white lead to the neutral lead and its green lead to ground. When the Model A is to be connected to DC power, its black lead should be connected to the negative (-) lead, its white lead to the positive (+) lead and its green lead to ground.
2. When the Model L siren is to be connected to AC power, one of its black leads should be connected to the phase lead, the other to the neutral lead and its green lead to ground. When the Model L is to be connected to DC power, one of its black leads should be connected to the negative (-) lead, the other to the positive (+) lead and its green lead to ground.

E. SPECIFICATIONS

1. Model A

Operating Voltage:	120 V AC/DC
Operating Current:	1.8A
UL Audibility Rating:	104 dB(A)
Sound Output:	103 dB(A) @ 10 ft. on axis

2. Model L

Operating Voltage:	120 V AC/DC 240V AC/DC
Operating Current:	1.95A (120 V) 0.9A (240 V)
Sound Output:	112 dB(A) @ 10 ft. on axis

SAFETY MESSAGE TO OPERATORS

Listed below are some important safety instructions and precautions you should follow:

- It is important that you read and understand all instructions before operating this system.
- All effective sirens produce a loud sound which may cause, in certain situations, permanent hearing loss. You should take appropriate precautions such as ensuring that the recommendations in OSHA Sound Level Standard (29CFR 1910) 1910.95 are not exceeded.
- Although your signaling system is operating properly, it may not be completely effective. People may not hear your signal. You must recognize this fact and take steps to ensure it is achieving the desired effect.

II. MAINTENANCE

Other than cleaning, no regularly scheduled maintenance is required. To ensure unit is operating properly, it should be tested at regularly scheduled intervals.

In the event repair is required, listed below are some safety instructions and precautions you should follow.

WARNING

Failure to follow all safety precautions and instructions may result in property damage, serious injury, or death to you or others.

SAFETY MESSAGE TO MAINTENANCE PERSONNEL

Listed below are some important safety instructions and precautions you should follow:

- Read and understand all instructions before operating this system.
- Optimum sound distribution will be reduced if siren becomes clogged with a foreign substance. Periodic checks should be performed to ensure no foreign matter is packed into the siren.
- Any maintenance to the signaling system must be performed by a trained electrician in accordance with NEC Guidelines and local codes.
- Any maintenance to the signaling system must be done with power turned off.

- Never alter the unit in any manner.
- The nameplate, which may contain cautionary or other information of importance to maintenance personnel, should not be obscured if exterior of housings are painted.

III. SERVICE.

Federal Signal will service your equipment or provide technical assistance with any problem that cannot be handled locally.

Any units returned to Federal Signal for service, inspection, or repair must be accompanied by a Return Material Authorization. This R.M.A. can be obtained from the local Distributor or Manufacturer's Representative.

At this time, a brief explanation of the service requested or the nature of the malfunction should be given.

Address all communications and shipments to:

Industrial Systems
 2645 Federal Signal Drive • University Park, IL 60484-3167
 Tel.: 1-708-534-4756 • 1-877-289-3246 • Fax: 1-708-534-4852
www.federal-signal-indust.com • www.fs-isys.com

IV. REPLACEMENT PARTS.

Description	Part Number
Motor and Rotor Service Kit	K8118052