



These instructions are provided to assist you in the installation of the field installed accessories (CZBB, CZTDP, and CZSM) for use in CZ and FCC Series wall heaters. Refer also to the installation manual provided with the heater for additional warnings and instructions.

**WARNING**

**ELECTRIC SHOCK HAZARD. MAKE SURE POWER IS DISCONNECTED AT MAIN SERVICE PANEL BEFORE INSTALLING THESE ACCESSORIES.**

**Back-Box Model CZBB:**

The back-box is sold separately to allow for rough in installation and to allow for the purchase of the CZ-IF heaters units for later installation.

The back-box may be recess mounted into a standard 2" x 4" stud wall or may be surface mounted using the model **CZSM Surface Mounting Frame**. If surface mounting, refer to *Installation of Model CZSM Surface Mounting Frame*.

**Installation in New Construction:**

Locate back-box so one side of box is adjacent to a wall stud and front surface flush with the finished wall surface. The following minimum clearances must be maintained:

- Bottom of box to floor – 4-1/2" (115 mm)
- Side of box to adjacent wall – 6" (153 mm)
- Top of box to ceiling – 36" (915 mm)

The rubber shim (provided with back-box) should be installed as shown in Fig. 1 to allow box to square up with stud and finished wall. Secure box to stud with two screws

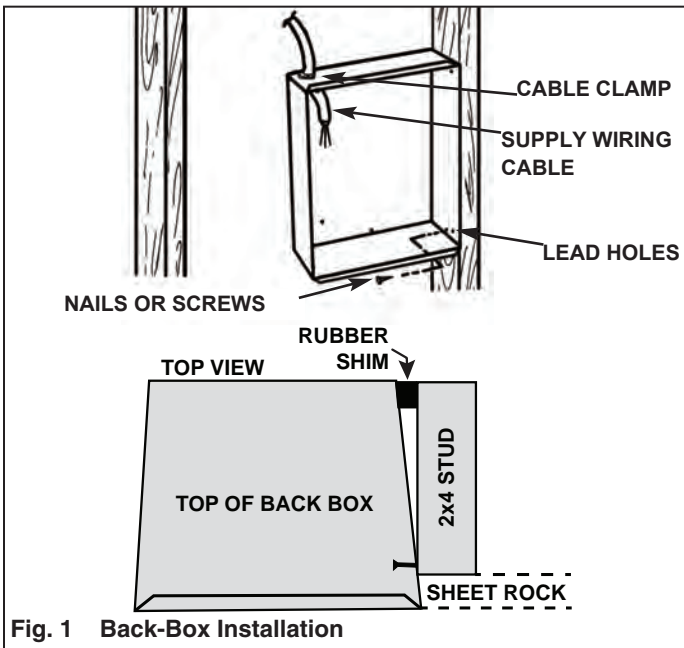

**Fig. 1 Back-Box Installation**

Bring power supply to heater, remove desired knockout in back-box, install cable clamp, and route cable into box leaving adequate length to allow ground wire to be attached under green colored ground screw near bottom of box.

**Installation in Existing Construction:**

Locate wall stud so heater can be installed while maintaining the following clearances:

- Bottom of box to floor – 4-1/2" (115 mm)
- Side of box to adjacent wall – 6" (153 mm)
- Top of box to ceiling – 36" (915 mm)

Carefully cut a hole measuring 7-7/8" (200 mm) wide by 10" (254 mm) high so side of box will fit against stud. Bring power supply to heater, remove desired knockout in back-box, install cable clamp, and route cable into box leaving adequate length to allow ground wire to be attached under green colored ground screw near bottom of box.

The foam shim (provided with back-box) should be installed as shown in Fig. 1 to allow box to square up with stud and finished wall. Slide box into wall opening and secure box to stud with two screws making sure front of box is flush with finished wall.

**Surface Mounting Frame Model CZSM:**

This accessory provides for surface installation of the CZ series heaters and provides for a finished appearance. This accessory installs between the back-box and wall as shown in Fig. 2.

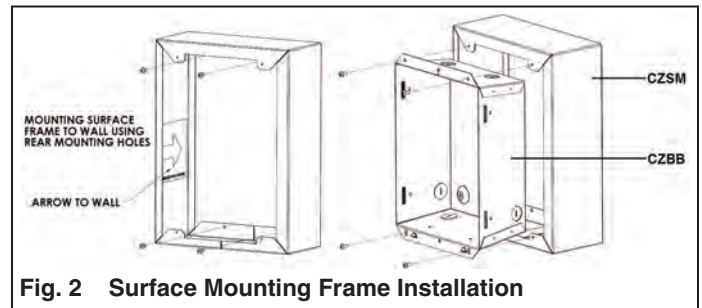

**Fig. 2 Surface Mounting Frame Installation**

1. Locate desired mounting location for heater maintaining required clearances. Position CZSM assembly to wall and secure using four (4) holes in back as shown in Fig. 2.
2. Route branch circuit power cable to heater location. Cable can be routed in wall or in surface conduit. If in wall, bring cable into the interior of frame so it is near sides to allow for the back-box to fit into the space. Remove desired knockout in back-box, route cable into box leaving adequate length to allow ground wire to be attached under green colored ground screw near bottom of box. If surface conduit is to be used, a knockout is provided at bottom of surface frame for entrance of the conduit and cable. Route cable into back-box allowing approximately 8 inches of cable for connections.
3. Fit back-box into surface frame making sure two tabs, provided to secure heater/fan assembly to back-box, are at bottom. Secure back-box to surface frame using four (4) screws provided.

Follow the instructions provided with heater to complete the installation.

### DP Thermostat Model CZTDP:

This accessory is provided for field installation into the CZ series models with -IF suffix. Refer to Fig. 3 for location and mounting of this control in the heater.

### Thermostat Operation

After heater and thermostat are fully assembled, rotate thermostat knob fully counter clockwise (CCW). This is the OFF position and should have a dimple to indicate this position on grille.

Energize heater and check to make sure heater is not operating. If it is, shut off power and check wiring.

Rotate thermostat knob to the full clockwise (CW) position. Heater should immediately power on and operate as intended. If it does not, shut off power and check wiring.

Allow heater to operate until room temperature reaches a desired level and then slowly rotate thermostat knob CCW until it clicks. The heater should stop heating. At this position, the heater should cycle on and off to maintain this desired comfort level. Slight adjustments may be necessary. To increase the comfort level, it may be necessary to rotate knob in CW direction. To decrease, rotate in the CCW direction.

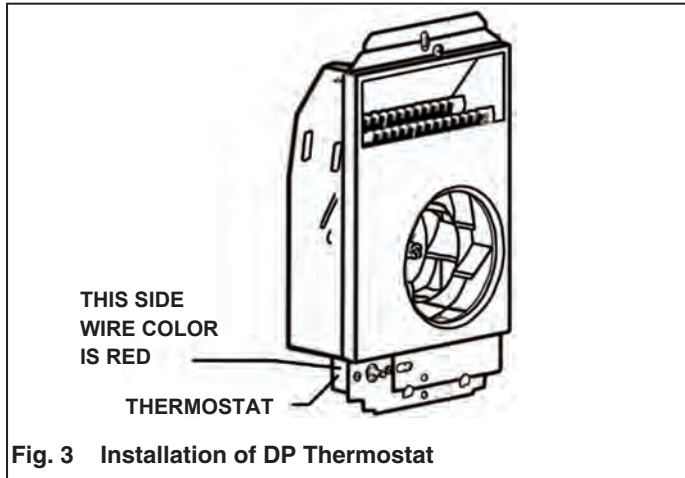

Locate two machine screws in parts bag and mount the thermostat to the back of the heater frame as shown in figure 3.

Referring to wiring diagram Fig. 4, make connections to heater leads using wire nuts provided. Note terminal markings on back of thermostat case.

Refer to heater installation instructions to complete the wiring and heater installation.

After heater is installed and grille is in place, install thermostat knob onto thermostat shaft by lining up the flat side on the shaft with the flat side in knob and pushing knob onto shaft.

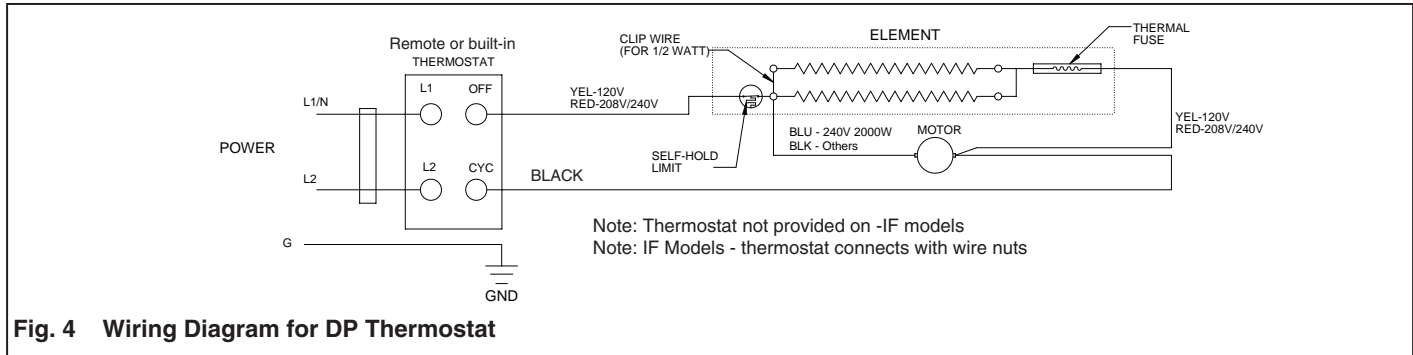

Fig. 4 Wiring Diagram for DP Thermostat

### HOW TO OBTAIN WARRANTY SERVICE AND WARRANTY PARTS PLUS GENERAL INFORMATION

- |                                |                   |
|--------------------------------|-------------------|
| 1. Warranty Service or Parts   | 1-800-642-4328    |
| 2. Purchase Replacement Parts  | 1-800-654-3545    |
| 3. General Product Information | www.marleymep.com |

Note: When obtaining service always have the following:

1. Model number of the product
2. Date of manufacture
3. Part number or description



470 Beauty Spot Rd. East  
Bennettsville, SC 29512 USA