



INSTRUCTION MANUAL

INS405-201411-02



OWF-R Series

Floor Heating Cable
for Installation with Strapping



Warranty

Subject to provisions stipulated in the Consumer Protection Act's legal requirements respecting the quality and durability of goods: Ouellet Canada Inc. guarantees its OWF-R series heating cables for a period of 25 years from the date of purchase against any manufacturing defect or malfunction.

Limitations and exclusions

The above mentioned guarantees are limited to the reimbursement of the original purchase cost or replacement of the heating cables (hereinafter called "equipment") excluding any other part and also excluding any cost or any expense relating to connection, removal or installation of aforesaid equipment, including all workmanship costs. The buyer may choose between the reimbursement of the original purchase cost and the replacement of defective equipment, subject to the aforementioned restrictions. This warranty is provided to the original buyer of the equipment as well as subsequent owners of the building where the equipment was installed.

Warranty terms

The above mentioned warranties are subject to the following conditions:

- i. The buyer must provide the original purchase invoice for the defective equipment, to Ouellet Canada Inc. or to one of their authorized dealer.
- ii. The buyer must report promptly in writing to Ouellet Canada Inc. any malfunction of equipment covered by the present warranties, in a reasonable time frame, from the time the malfunction occurred or the malfunction was brought to their knowledge thereby enabling Ouellet Canada Inc. representatives enough time to verify the defective equipment, if need be.
- iii. Equipment covered under the present warranties must be installed in compliance with Ouellet Canada Inc. instructions.
- iv. Equipment covered under the present warranties must be used under normal conditions of use and be maintained on a regular basis from the date of purchase.

Name and address of the person providing the present warranties:



Ouellet Canada Inc.

180, 3^e Avenue

L'Islet (Québec) G0R 2C0 CANADA

Telephone: 1 800 463-7043 or 418 247-3947

Fax: 1 800 662-7801 or 418 247-7801

info@ouellet.com

www.ouellet.com

Table of contents

1	Warnings and cautions	2
2	Product specifications and details	3
3	Selection of floor heating system	4
4	Critical information	5
5	Selection of floor covering material	7
6	Thermal insulation	8
7	Installation instructions	9
	7.1 Room layout and corresponding floor heating system product	9
	7.2 Work planning	10
	7.3 General recommendation and subfloor preparation	10
	7.4 Identification of components	13
	7.5 Floor marking	17
	7.6 Installation of the floor heating system	18
	7.7 Installation of the temperature sensor	19
	7.8 Application of the self-levelling cement	20
	7.9 Final view	20
8	Electrical connection	21
9	Operation of the floor heating system	22
10	Control device	22
11	Operating tips	21
12	Locating a fault	21
13	Control Card	23



CAUTION!

Please read through these instructions carefully before you begin installing & check that you are aware of all the components required.

1 Warnings and cautions



Risks of electrical shocks and fire



For safe installation and efficient performance of this system, read the instruction manual thoroughly and keep it handy.

- Where applicable, installation must meet requirements of the following codes:
 - Canadian Electrical Code (CSA C22.1 Part 1);
 - National Electrical Code (NFPA 70);
 - Any other applicable local and/or national code.
- Where required by law, this product must be installed by a qualified person.
- To prevent any possibility of electrical shocks, the power supply must be turned off before handling the heating cables.
- **A GROUND FAULT PROTECTION DEVICE MUST BE USED WITH THIS PRODUCT, UNLESS EXEMPTED BY ELECTRICAL CODE IN FORCE.**
- This heating cables must be used for indoor applications only.
- The heating cable and the mechanical joint (junction) must be installed and fully embedded in cement or an equivalent binder (cement glue, ceramic glue or self-levelling cement).

SAVE THESE INSTRUCTIONS

2 Product specifications and details

The floor heating system is designed exclusively for interior floor heating. The system is not designed for snow melting or any other outdoor uses; it is mainly designed to complement a building's primary heating source by serving as a secondary (floor warming) or primary room heat source (radiant floor heating).

This heating system is made of a twin conductor heating cable combined to a 10' (3 m) cold lead.

The heating cable consists of a resistance-heating element insulated with Fluoropolymer having high dielectric strength and high temperature withstand ability, which makes the heating cable safe. A metallic sheath provides additional mechanical strength and a ground path. A final PVC outer jacket makes it sturdier and provides corrosion protection. The hot and cold lead junction is uniquely designed to make it fool proof.

The heating cables are available in a wide range of capacities and lengths to suit your requirements.

3 Selection of floor heating system

Selection of floor heating system will depend on the application.

Maximum allowed installation is 12 W/ft² (130 W/m²) for heating and comfort applications.

Depending on the claimed result, the cable system can also be used in lower density applications. To ensure optimal heating results, please contact a qualified person.

Wet areas (in locations subject to saturation with water) like showers, saunas and steam rooms, bathrooms, etc: 12 W/ft² (130 W/m²).

Note: *The floor heating system can be installed under a shower floor only if the floor is ceramic or natural stone. A waterproof membrane must be used to maintain the heating cables in a dry environment. The manufacturer recommends using a separate cable for the shower area. The UL listing for this product does not cover use in wet location in the United States.*

Please note the above-indicated values are meant as a general guide, actual requirement will depend on insulation levels, floor construction, type of floor coverings, ambient temperature, movement of the people etc.

4 Critical information

- 1 **Heating cable must not touch, crossover or overlap itself** at any point. (Please use strapping to avoid bunching or crossover of cable). This could cause the cable to overheat.
- 2 **Heating cable cannot be cut or shorten.**
- 3 The **heating cable length cannot be altered** in any circumstances. This may cause over heating resulting in damage to the cable.
- 4 **Take precautions to avoid damage to the heating cable** during installation, due to dropping sharp objects or stepping or careless pouring of concrete or banging the trowel on the heating cable while applying cement mortar for tiling/flooring. In case of remodeling of floors, make sure that old mats/cables are removed before you lay new heating cables.
- 5 **Heating cables should be separated from other heat sources** such as floor luminaries and chimneys.
- 6 **Do not install the heating cable below 5 °C (40 °F) ambient temperature.**
- 7 **Minimum bending radius** of the heating cable while laying shall not be less than **1" (2.54 cm)**. The **mechanical joint** between the cold lead and the heating part of the cable **must not be bent**.
- 8 **If Thermal Insulation Boards of adequate thickness is used, please ensure the item has R Value of 0.027 or less.**
- 9 Floor thermostat sensor location shall be centered between two adjacent runs of heating cable.
Do not locate floor thermostat sensor closer than 1" (2.54 cm) to heating cable or allow to overlap any other cable.
- 10 **Maximum limit of the temperature setting on the thermostat should not exceed 30 °C (86 °F).**
- 11 **Check the main voltage and wattage** of the heating cable as per the selection made. These are indicated on the product name plate.
- 12 Keep the power leads conduit separated from the floor temperature sensor cable conduit.
- 13 It is highly recommended to connect **the Cablecheck electrical fault indicator** at the free end of the cold lead during the installation to warn about accidental damage to the heating cable or lead wires.
- 14 In case GFCI trips during normal operation, and cannot be reset, there is likely a fault in the cable. No attempt should be made to re-energize the heating cable. **GFCI must not be bypassed in any circumstances.** Consult a qualified person.
- 15 **Do not install** the heating cable under permanent fixtures.
- 16 **Allow** sufficient drying or curing period of the subfloor and finished floor before and after installing the heating cable.
- 17 Indicate which branch circuits supply the power to the heating cable and retain the UL labels for each heating cable in a convenient location, i.e. taped to the circuit breaker box, for reference by the electrical inspector or home owner. Leave one UL label attached to the heating cable. Attach warning label in convenient location to show the room location where heating cable is installed.
- 18 Use only listed conduit, fittings, and or other components.
- 19 Heating cables shall not extend beyond the room or area in which they originate.
- 20 This heating cable shall be installed only by qualified people who are familiar with the construction and operation of the heating cable and the risks involved.
- 21 The installation of the heating cable shall be in accordance with the manufacturer's instructions and local national codes.
- 22 The manufacturer recommends using a separate cable for the shower area. It can be installed under a shower floor only if the floor is ceramic or natural stone. A waterproofing membrane must be used to maintain the heating cable in a dry environment. The UL listing for this product does not cover use in wet location in the United States.
Note: *The UL Listing for this product covers use in wet locations for CANADA only. Wet location installation in United States shall be in accordance with the National Electric Code, (NFPA 70) and any other applicable jurisdictional code and final acceptance is to be made by the Authority Having Jurisdiction (AHJ).*
- 23 Use copper wires only.
- 24 The heating cable (including the mechanical joint) must not be installed in walls.

25 Install the temperature control where it is not accessible from the shower or bath (install at least 3' 4" (1 m) away).

26 Required distances and clearances

CAUTION!

NEVER install a heating cable under an interior wall or any fixed unit, a closet or in any other location where air cannot circulate freely over the floor surface. Always maintain the following minimum clearance:

- 3" (7.6 cm) between heating cables;
- 3" (7.6 cm) from any exterior wall, interior wall, drain, or any fixed obstacle you need to go around;
Note: 10" (25.4 cm) from a toilet drain with a wax ring seal.
- 3" (7.6 cm) from any fixed unit (e.g., vanity sink, shower, refrigerator), etc;
- 8" (20 cm) from any heating appliance affixed to or in contact with the floor;
- 2" (5 cm) between the floor surface and the furniture to allow air to circulate freely;
- 0.5" (1.3 cm) between the heating cable and any exposed combustible surface;
- 10' (3 m): maximum length of a free cable in a straight line.

27 The system is only one step in the floor construction process. Each trade is responsible for the quality of its work and must ensure that the work performed by the previous tradesman has been duly completed according to code. All tradesmen are engaged in the installation process and share joint responsibility for it.

28 Perform all six (6) insulation and resistance test steps required during installation:

- 1 Before breaking the security seal and opening the product.

Note: Once the seal is broken, you are then in charge of the cable integrity throughout the entire installation process. Be sure to follow instructions and observe all precautionary measures.

- 2 After the installation of the heating cable.

- 3 Before embedding the heating cable.

- 4 After embedding the heating cable.

- 5 After the final installation of flooring.

- 6 Before connecting the heating cable system.

- Enter results in the measurement table found in the envelope. All 6 measurements must be correctly recorded for the warranty to be applicable.

- Once completed, affix the measurement table to electrical panel and mark the specific circuit breaker that powers the heating cable circuit.

A qualified electrician must measure the system's insulation resistance as follows:

Megohmmeter

- Use a calibrated megohmmeter only;
- Measure insulation resistance at the free end of the cold lead, between the phase conductors and ground;
- Write the reading in the measurement table;
- This reading must be over 1 000 000 ohms;
- If the reading is under 1 000 000 ohms, stop work and contact the manufacturer's technical support.

Multimeter

- Use a calibrated multimeter only;
- Measure resistance at the free end of the cold lead, between the two phase conductors;
- Write the reading in the measurement table;
- Verify the heating cable integrity by comparing your reading to the value on the cold lead label;
- If your reading is very different from the nominal resistance at any step, stop work and contact the manufacturer's technical support.

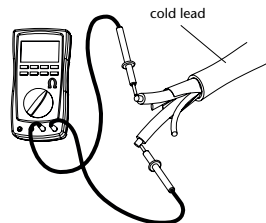
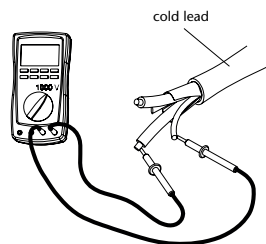

CAUTION! Dangerous Test



WARNING!

"Risk of electric shock and fire".

"Damage to supply conductor insulation may occur if conductors are routed less than 3" (7.6 cm) from this heating product. Refer to installation instructions for recommended means of routing supply conductors".



5 Selection of floor covering material

Caution: Check with the manufacturer to make sure your floor covering is compatible with the heating cable system.

The type and thickness of floor covering materials used with this product must not exceed a thermal insulation "R" value of 1 (RSI = 0.123).

There is no thermal insulation limit under the floor.

Typical floor covering	Thermal resistance	
	R	RSI
Vinyl tiles	0.20	0.035
Linoleum	0.22	0.039
Ceramic	0.25	0.044
Low-pile carpet	1.0	0.123
Natural stone (Granite, limestone, marble, sandstone) 1" thick	0.38-0.114	
Plywood 0.5" thick	0.63	
Parquet flooring	0.70	0.123
Floating floor 10 mm to 16 mm (3/8" to 5/8") (Laminate)	0.70	0.123
Wood on lathes (strapping)*	2.10	0.368



IMPORTANT!

For engineered wood floorings, laminated hardwood flooring, vinyl coverings, and linoleum glued to a concrete surface, consult your floor covering manufacturer to ensure they are compatible with floor heating systems.

6 Thermal insulation

The insulation levels of a floor will affect both the performance & running costs of the floor heating system.

The thermal insulation reflects the heat upwards into the floor instead of allowing heat to penetrate into the sub-floor and keeps the floor warmer for a longer period of time. While installing the floor heating system, user should install adequate thermal insulation below it. In cases where the floor heating system is being installed over large areas, insulation boards will greatly reduce warm-up times & running costs.

When floor heating systems are installed on a concrete slab, we strongly recommend adding a layer of insulation to the slab prior to installing the heating cables. Adding insulation on top of the concrete slab or board, and beneath any floor heating system will allow a greater percentage of heat generated to transfer to the flooring surface.

The heating cable system is approved for the following type of installation:

- On a subfloor



CAUTION!

The subfloor material in contact with the heating cable must be able to withstand a temperature of at least 90 °C (194 °F).



IMPORTANT!

The efficiency will depend on factors such as available surface of the room to be covered with heating cable (or sufficient percentage of the surface to be heated), heat conductivity of the floor covering, insulation on outside walls, etc. We recommend that you verify these points and seek professional advice before investing time and money.

7 Installation instructions

7.1 Room layout and corresponding floor heating system product

Plan the installation taking into account the guidelines below.

- Create a room layout plan to scale (for maximum accuracy, use the manufacturer form designed for this purpose);
- Identify all stationary elements (toilet, bath, shower, counters, dressers, and permanent furnishings) and never install the heating cable under these stationary elements (Figure 1);
- Determine thermostat or temperature control location;
- Indicate all the dimensions of the space that requires heating;
- Determine the electric cable (cold lead) location that will be connected to the heating control;
- When calculating the area to be covered by the heating cable, remember that the cable must be installed 3" (7.6 cm) from any exterior wall, interior wall, drain, or any fixed obstacle you need to go around.
- Once you have determined the area to be heated, calculate total required output by multiplying area x watt density required for the room. Choose nearest suitable wattage cable from the available range. When calculated size required is between two sizes of offered cables, select the smallest of the two.

Cable rating	Density and distance between cable			
	3 inches	4 inches	5 inches	6 inches
9.84 W/m (3 W/ft.)	12 W/sq.ft.	9 W/sq.ft.	7.5 W/sq.ft.	6 W/sq.ft.

Each cable's length is listed in the product sheet; combine cables if more than one is being used.

We recommend the installation of the cable at a spacing of 3 or 4 inches for an uniform floor temperature.

Room layout example

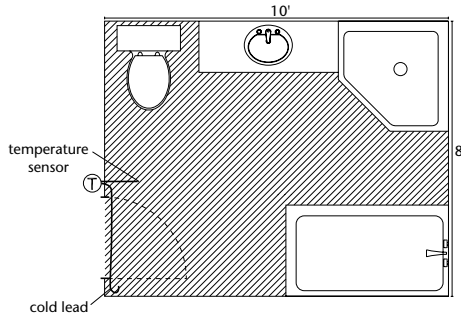

Figure 1



Need help to optimize your work plan? Contact our technical support. Clearly indicate all dimensions. A minimum of one horizontal and one vertical dimensions are necessary to validate the scale.

7.2 Work planning

Materials provided by the manufacturer

- Heating cable
- Installation strappings
- Installation instructions
- Measurement table label
- Floor temperature sensor

Note: Always use the temperature sensor supplied with the thermostat. The temperature sensor supplied with the heating cable is installed in case of failure of the thermostat sensor.

Material required

- Temperature control with GFCI (available at the manufacturer)
- Electrical fault indicator (available at the manufacturer)
- Stapler
- Screws
- Safety glasses
- Measuring tape
- Broom
- Felt marker
- Tape
- Hot glue gun
- Wood chisel
- Hammer
- Multimeter and megohmmeter
- Electrician tools
- Electrical tape

For installation over a concrete slab, add the following:

- Concrete chisel
- Drilling machine
- Percussion drill for concrete

7.3 General recommendation and subfloor preparation

- Clean and remove any debris, dust, or protruding objects that could damage the heating cable;
- Subfloor cracks must be filled with polyester wood filler;
- The subfloor must be solidly fastened in place to prevent movement;
- For concrete subfloors, apply a surface sealer that is compatible with electrical heating systems in accordance with the cement glue manufacturer's instructions. Completely coat the surface;
- Always let the sealer dry before installing floor heating system (refer to the sealer's instructions for drying time).

7.4 Identification of components

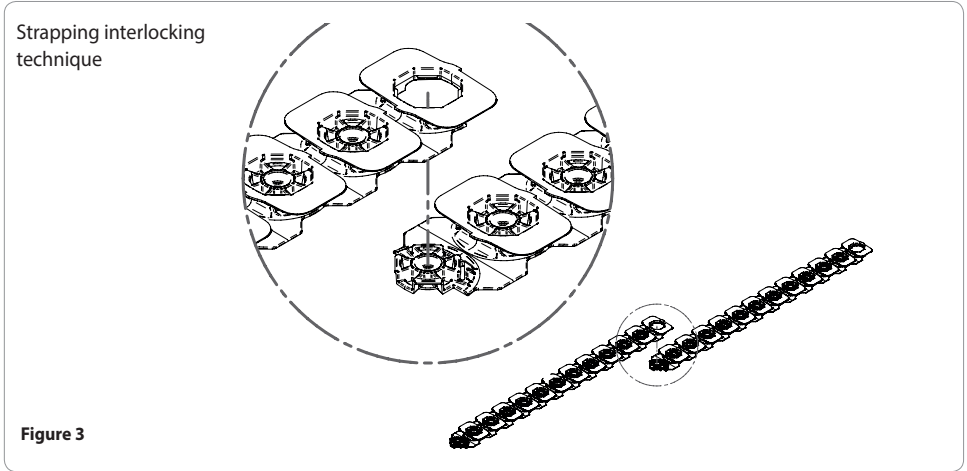
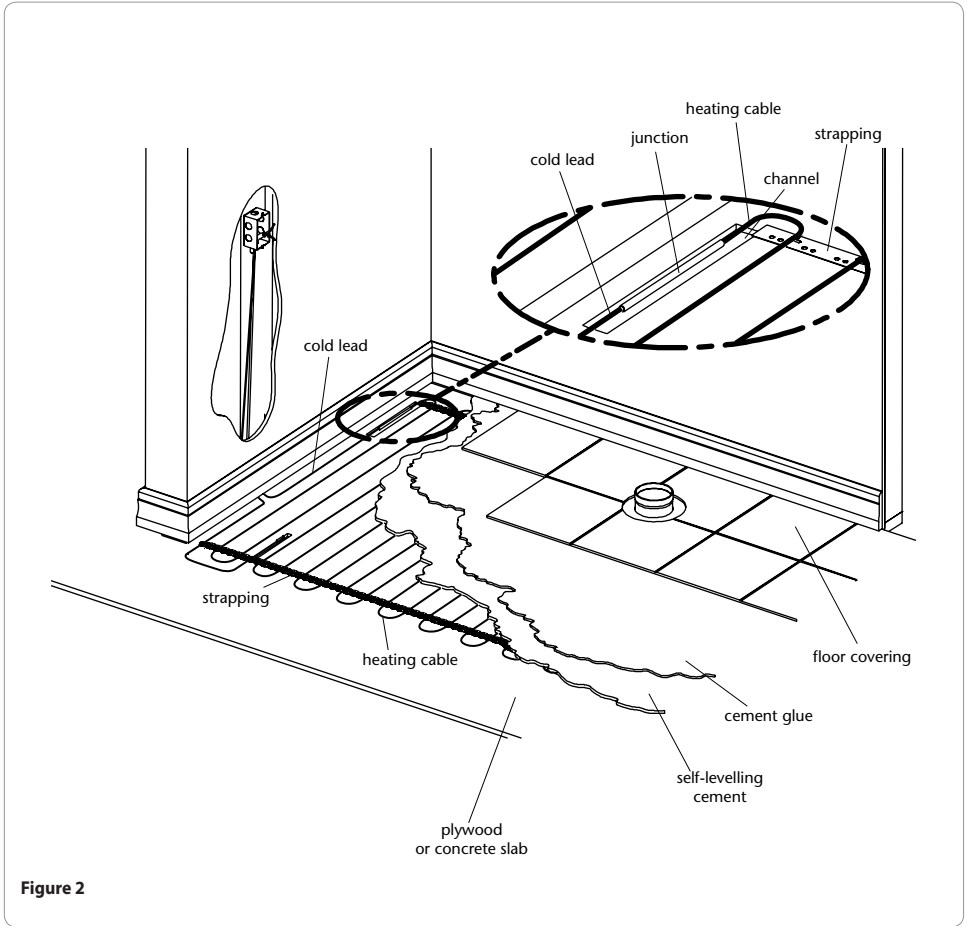
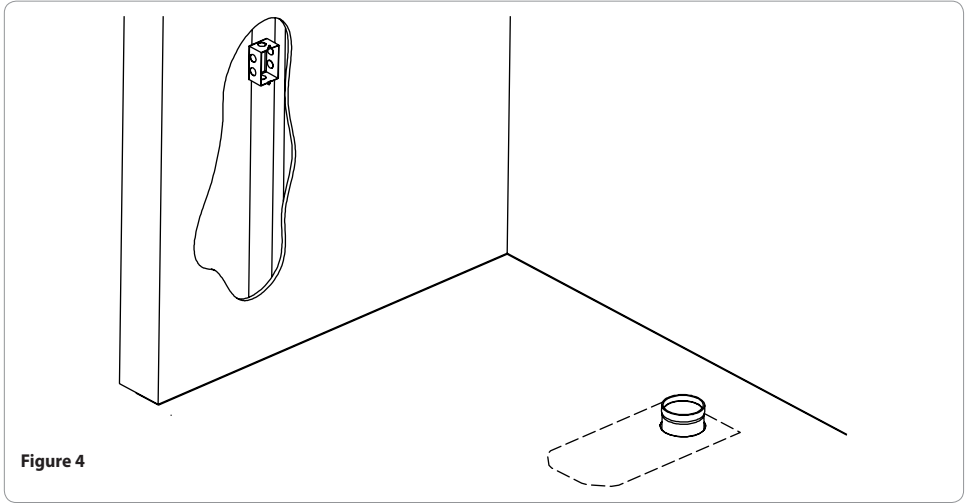

Figure 3

7.5 Floor marking

- On the floor of an empty room (under construction or major renovations), draw the location of stationary elements (toilet, bath, shower, counters, dressers, permanent furnishings) that will be installed later. These marks will outline the heating area to ensure the heating cable system is not placed under these stationary elements.



- The floor temperature sensor must be centered between two parallel heating cables. The ideal location is one where it is likely to be away from stationary objects and sheltered from outside influences (sunlight) that could skew floor temperature readings. For maximum comfort, the area above the sensor must be free of obstruction.

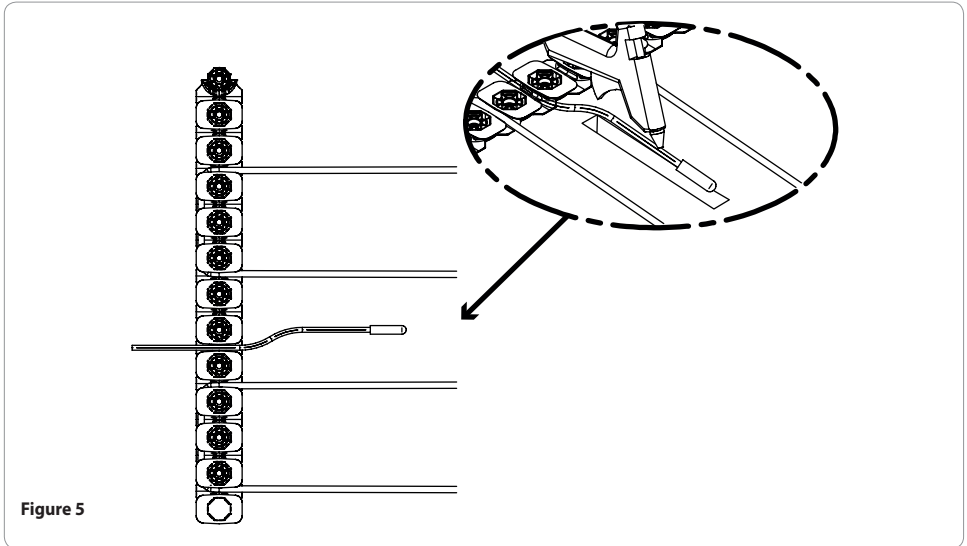

7.6 Installation of the floor heating system

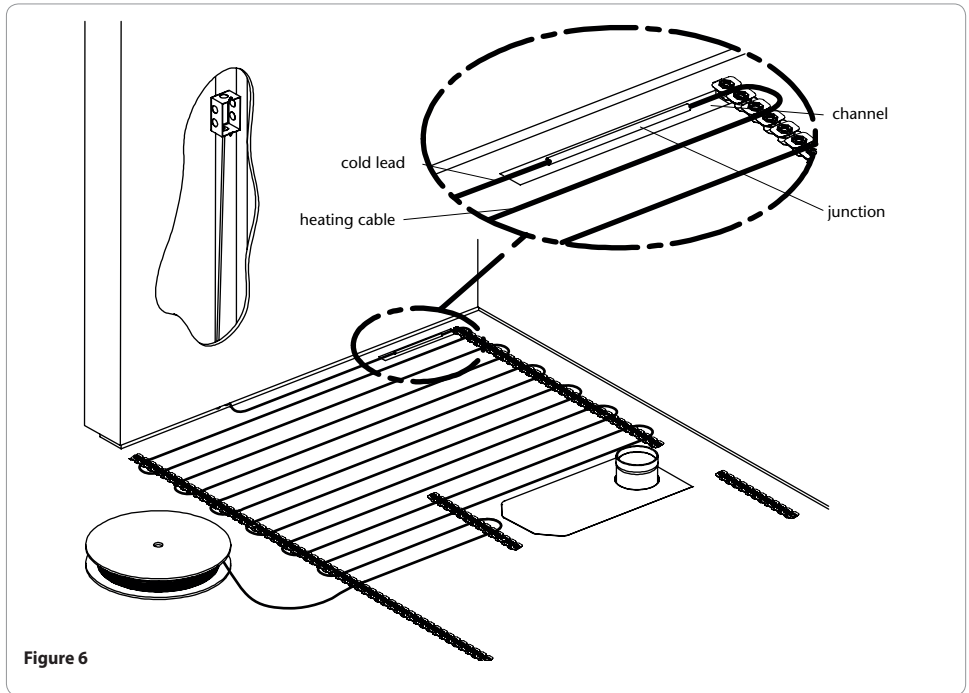
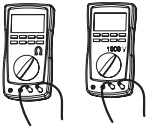

Figure 6



- 1) First insulation and resistance test.
Before breaking the security seal and opening the product, measure the cable's electrical and insulation resistance and record the readings on line 1) Before breaking seal.

Installation of the plastic strapping

- The strappings are fixed on the floor with staples or screws (when the floor is made of plywood or wood) or with a hot glue gun.
- The strappings must follow the outline drawn on the room layout (section 7.1).
- If the lacing distance between two strappings is over 2' (0.625 m), it is necessary to place an intermediate strapping to maintain the cable in position during the pouring of self-leveller. This strapping is installed at the end, after the lacing of the cable in order to have a good finish and aregular laying.
- The cable can be installed under the ceramic tile of a shower or other wet surfaces, the strappings and the heating cable must be glued under the waterproofing membrane and not stapled, staples could damage the waterproofing membrane. The UL listing for this product does not cover use in wet locations in the United States.

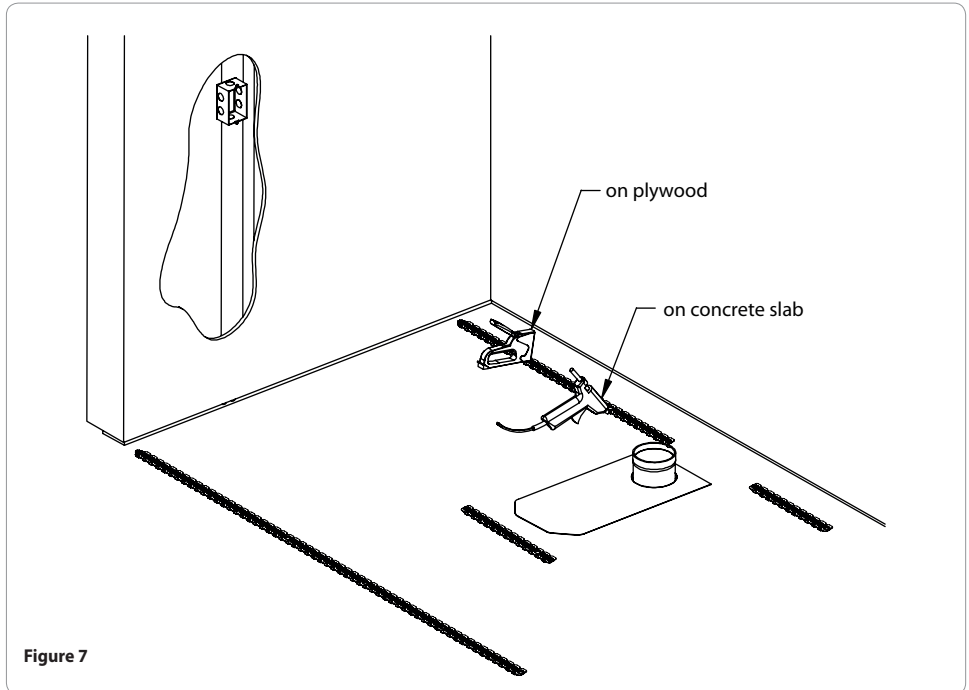

Figure 7

Installation of the heating cable

- Set the cable near the connection box. Ensure that the cold lead is long enough to be connected to the thermostat or junction box.
- To minimize floor height, chisel a 3/8" x 3/8" x 10" (10 mm x 10 mm x 250 mm) channel in the subfloor to receive the cold lead/heating cable junction. The junction has an extra insulation sheath and a slightly larger diameter than the heating cable. **Attention:** The mechanical joint (junction) must not be bent.
- Regularly lace the heating cable respecting the distance between the sections; 3" (7.6 cm) minimum.
- Do not bend the cable at 90° when setting it in the strapping hooks; leave a 1" (2.5 cm) radius. This radius comes naturally; the cable must not be forced to have a tight bend.
- A tag is located at 50% of the cable length. During installation of the product, verify the cable half tag to compare with your cable layout planification. Adjust pattern with the result to cover the surface. Never shorten the heating cable. The heating cable must not be shortened, neither cut.

- Always start the cable at least 3" (7.6 cm) from the walls.
- It is important not to subject the heating cable to any mechanical strain (stretching, bending radius under 1" [2.5 cm], scoring). **Attention:** The mechanical joint (junction) must not be bent.
- Avoid walking on the cable.

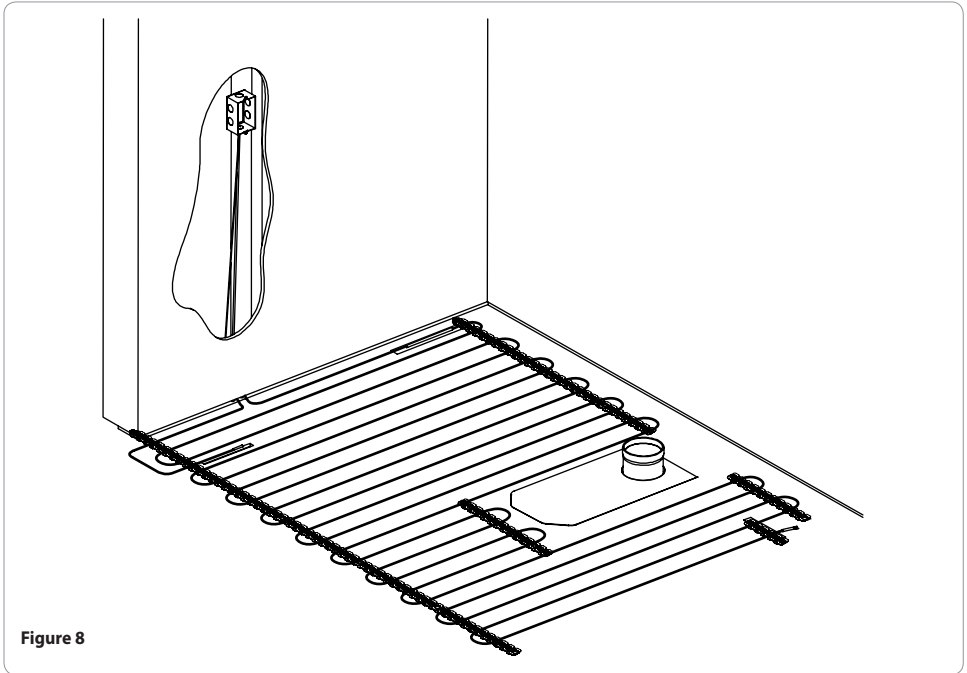
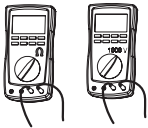

Figure 8



IMPORTANT!



2) Second insulation and resistance test.

After the installation of the heating cable, measure the cable's electrical and insulation resistance and record the readings on line 2) After cable installation.

7.7 Installation of the temperature sensor



IMPORTANT!

The sensor must be embedded in cement or an equivalent binder (cement glue, ceramic glue, self-levelling cement).

- The floor temperature sensor must be centered between two parallel heating cables. The ideal location is one where it is likely to be away from stationary objects and sheltered from outside influences (sunlight) that could skew floor temperature readings. For maximum comfort, the area above the sensor must be free of obstruction.
- To minimize floor height, chisel a $3/8" \times 3/8" \times 10"$ (10 mm x 10 mm x 250 mm) channel in the subfloor to receive the floor temperature sensor.
- Glue the sensor to the subfloor (figure 15). The sensor must be solidly fastened to the subfloor to ensure it stays in place when the cement or an equivalent binder (cement glue, ceramic glue, self-levelling cement) is applied.

Note:

- *It is recommended to install two (2) temperature sensors; in case of malfunction of the first one, the second sensor is already encased and ready for connection.*
- *Always use the temperature sensor supplied with the temperature control as your primary sensor. The one supplied with the heating cable should be used as back up.*

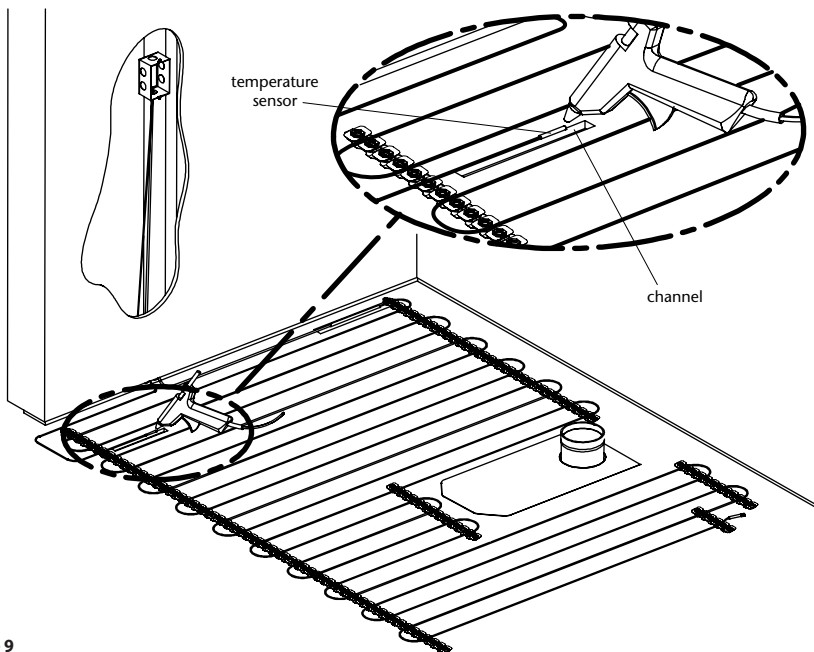
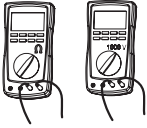

Figure 9

7.8 Application of the self-levelling cement



3) Third insulation and resistance test

Before embedding the heating cable in self-levelling, measure the cable's electrical and insulation resistance and record the readings on line 3) Before embedding the cable.



IMPORTANT!

All the heating portion of the cable (including the mechanical joint) must be completely embedded in mortar. The floor covering must be in direct contact with the mortar the cable is in.

- Applying a minimum 1/4" (6.4 mm) layer of self-levelling cement on the heating cable is recommended. To completely embed the cable in the cement or cement glue.
- Only use cement or an equivalent binder compatible with floor heating systems (cement glue, ceramic glue, self-levelling cement).
- Consult the manufacturer's instruction for the type of floor covering (ceramic, linoleum, or other) (see section 5).

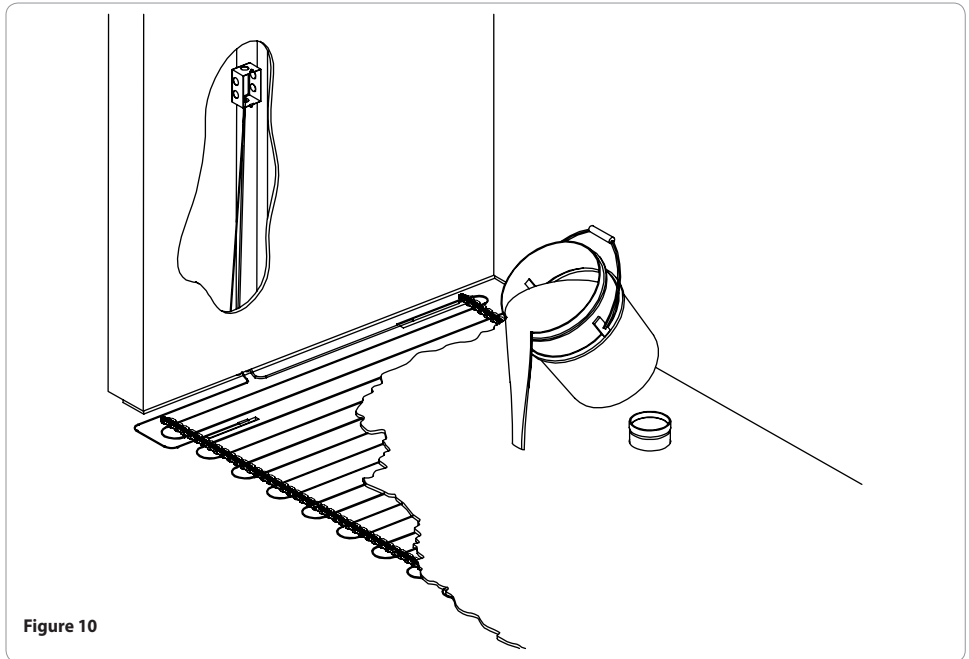
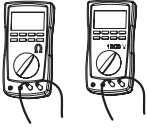

Figure 10



IMPORTANT!

Do not turn on the floor heating system before the cement has completely dried. Follow the manufacturer recommendations (may take up to 30-40 days, depending on the product).



4) Fourth insulation and resistance test.

Once the cement or binder has been applied, measure the cable's electrical resistance and record the readings on line 4) After embedding the cable.

7.9 Final view

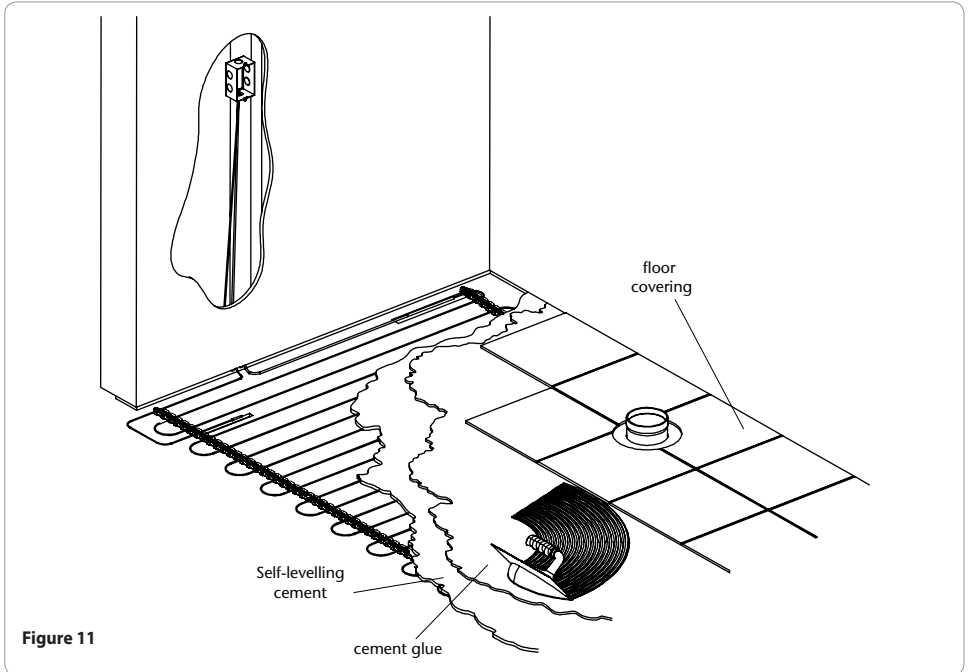
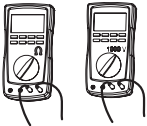

Figure 11



5) Fifth insulation and resistance test.

After final surfacing. Once the cement or binder has been applied and completely dried, measure the cable's electrical resistance and record the readings on line 5) After final surfacing.

8 Electrical connection



IMPORTANT!

Electrical connection must be performed by a master electrician, only after the cable has been installed and encased in concrete and the curing of concrete period is complete.
WARNING! DANGER OF ELECTROCUTION: always make sure the power supply circuit is turned off before proceeding with the electrical connection.



- 6) Sixth insulation and resistance test.
Before wiring system, measure the cable's electrical resistance and record the readings on line 6) Before wiring the system.

- 1 Perform the connection in compliance with instructions provided with the temperature controller and in compliance with local and national electrical specifications in effect.

Cold lead:

- 240V/208V connection
 - Line 1 - Black
 - Line 2 - Red
 - Ground - Yellow/Green
- 120V connection:
 - Neutral - Yellow
 - Line - Black
 - Ground - Yellow/Green

IMPORTANT

- Check product name plate to make sure that voltage supply is correct.
 - Never connect a 208/240V product at 347V or vice versa.
- 2 The master electrician who installed and connected the floor heating system must complete the measurement table (this label is available at the opening of the product) and give it to the customer. This label must be kept on the electrical panel.



CAUTION!

If the table is not duly completed, the warranty may be void. Warranty terms are set on the back of the cover page.

9 Operation of the floor heating system

The floor heating system is now ready for use. However, before turning on the system, make sure the curing period specified by the concrete manufacturer has expired. Adjust the thermostat's temperature based on your needs and desired comfort level.

10 Control device

Important

The floor heating system must be controlled by a temperature control system.

An electronic floor temperature control featuring a floor sensor is recommended to ensure heat levels never exceed the floor covering maximum temperature tolerance.

The room temperature control and floor temperature sensor must never be installed where they will be exposed to sunlight or air drafts.



IMPORTANT!

Recommended temperature regulation devices:

1 Thermostat with floor sensor and integrated GFCI (floor warming only).

2 Electronic ambient thermostat with a GFCI (radiant room heating).

For installations requiring more than one electrical circuit, get a set of adequate controls including a master thermostat and the required number of slave units, according to the total power of the system.

We recommend using a thermostat with floor sensor specially designed for the control of floor heating systems.

The floor sensor comes with a lead wire/cable of 15' (4.6 m) length.

The floor sensor location shall be centered between two adjacent runs of heating cable.

Sensor cable shall be routed to the thermostat located in the wall at suitable operating height.

Do not allow any other cable to overlap with the sensor cable. Maximum limit of the temperature setting on thermostat should not exceed 30 °C (86 °F).

The details of thermostat installation will be available in the instruction manual provided with the thermostat.

*****Refer to instructions that came with your specific thermostat for electrical schematics*****

11 Operating tips

- 1 When first energized, the heating cables may take sometime to fully warm your floor.
- 2 Energy consumption will vary depending on user preferences.
- 3 Energy consumption can be minimized by turning the system OFF when floor heat is not required, but you will have to allow time for the floor to warm up once the system is turned ON again.
- 4 Do not place thick mats/rugs/floor level furniture/mattresses on your heated floor. These restrict the heat transfer and may result in the cable overheating.
- 5 Avoid mats with rubber or vinyl type backing, as these may decompose with heat and could stain flooring.

12 Locating fault

If the cable gets damaged during installation, the **Cablecheck** electrical fault indicator (sold separately) will warn you about the damage.

Electrical fault finding

Once the system has been turned off and made safe, have a qualified person:

- 1 Ensure all wires have been connected as per the wiring diagrams;
- 2 Make sure multiple rolls have been wired in parallel and not in series;
- 3 Confirm that control devices are receiving correct voltage.

Using a well calibrated multimeter with good batteries, or preferably, a digital multimeter, the ohm resistance level of each heating cable should be checked and the reading compared with the resistance that was recorded during installation and the nominal value indicated on the corresponding CSA label.

If your reading is not within the original reading range, the cable may have been damaged in some way.

This indicates an open or short circuit beneath the finished flooring. The qualified individual must locate the point of break or short.

At all time, turn off the power at the main panel and disconnect the heating cable from the thermostat to take readings.

Locating a break or a short

If your installation is complete, all wiring connections have been verified to be correct, including grounding of the system, you have checked the sensor wire for proper Ohms reading, and you suspect the system is still not working; you need to determine if there is a break or a short under the floor.



WARNING!

Danger of electrocution.

- ***Always make sure the power supply circuit is turned off at the panel before proceeding with tests.***
- ***Always disconnect the heating cable from the controller to take reading.***

Checking for breaks

The ohm resistance of each cable should be measured. Make sure the probes of the multimeter do not touch the ground wire of the power connector. Make sure you do not touch either of the probe ends, or the meter will be reading your internal body resistance.

Make sure your multimeter is set on the proper scale (0 to 2000Ω for heating cable, or 0 to 20,000Ω for the floor temperature sensor wire).

Your ohm resistance readings should be within +10%/-5% of the nominal resistance indicated by the factory on the CSA label.

If your ohm reading is within +10% / -5% of what it should be, there is no break. However you still need to check for an electrical short.

If your ohm reading is lower (outside the range), but there is clearly some continuity, check your multimeter and your batteries. If these are good, there is a possibility that you have several electrical shorts.

If you have absolutely no reading (infinity on your meter), and you are sure you adjusted the setting of the multimeter to the correct reading range (0 to 2000Ω for the heating cable, or 0 to 20,000 Ω for the floor temperature sensor wire), then you have a break (total cut) in the conductor.

Checking for electrical short:

In some rare occasions an installation may have suffered from a high pressure point that broke the insulation between the core conductor and the metal sheath. Such opening in the insulation layer can create an electrical short, even though the Ohm reading from the line conductor to the other line conductor is normal and does not indicate any circuit break. In these rare occasions a continuity test will show continuity between the line conductor and the ground wire, and/or between the other line core conductor and the ground.

There should be no continuity ("infinite" resistance reading, not zero) between the line conductor and the ground.

There should be no continuity ("infinite" resistance reading, not zero) between the other line conductor and the ground.

If your instrument reveals continuity between both the line conductors and the ground, there is a short in the circuit.

There are three ways to locate breaks or electrical shorts with underground fault detectors:

- 1 A break can be found with a "thumper", an impulse-generating device that generates a sound at the break point. The thumper includes a stethoscope to locate the exact placement of the break under the floor.
- 2 A short can be found with a "time domain reflectometer" tester, which will measure the distance of the wire between the tester and the short point.
- 3 Breaks and shorts may generate some heat and they can also be found with infrared cameras scanned over the floor.

13 Control card

Perform all six (6) insulation and resistance test steps required during installation:

- 1 Before breaking the security seal and opening the product.

Note: *Once the seal is broken, you are then in charge of the cable integrity throughout the entire installation process. Be sure to follow instructions and observe all precautionary measures.*

- 2 After the installation of the heating cable.
- 3 Before embedding the heating cable.
- 4 After embedding the heating cable.
- 5 After the final installation of floor covering.
- 6 Before connecting the heating cable system.

Enter results in the measurement table found in the envelope.

Affix the measurement table to the electrical panel, once completed.

Tableau de mesures - Apposer au tableau électrique Measurement table - Place in electrical panel	Résistance Resistance (Ω)	Isolation Insulation > 1M Ω
Résultats d'usine/Factory results	Ex. : 11.52	OK
1. Avant de briser sceau/ <i>Before breaking seal</i>		
2. Après la pose du câble/ <i>After cable installation</i>		
3. Avant l'enrobage du câble/ <i>Before embedding cable</i>		
4. Après l'enrobage du câble/ <i>After embedding cable</i>		
5. Après la pose finale du revêtement/ <i>After final surfacing</i>		
6. Avant raccordement du système/ <i>Before wiring system</i>		