

High Bay 360° Passive Infrared Line Voltage Occupancy Sensor Control Module

MODEL: IOS-HB-U

INSTALLATION AND CONFIGURATION INSTRUCTIONS

Specifications:

Voltage - 120/277 VAC, 60 Hz

Load Requirements:

- @ 120VAC, 800W Tungsten 800 VA Electronic Ballast
- @ 277VAC, 1600 VA Electronic Ballast

Motor:

- @ 120 VAC 1/4 HP

Adjustable Light Level - 10FC-150FC

Sensitivity Adjustment - 50% or 100% (DIP switch)

Coverage -

Lens A: Mounting height-50 ft Field of view-360° Coverage-2800 sq. ft.

Lens B: Mounting height-8 ft Field of view-360° Coverage-1200 sq. ft.

Relative Humidity - 20-90%, non-condensing

WARNING Risk of Fire, Electrical Shock or Personal Injury

- Turn OFF power at circuit breaker or fuse and test that the power is OFF before wiring.
- To be installed and/or used in accordance with appropriate electrical codes and regulations.
- If you are not sure about any part of these instructions, consult a qualified electrician.
- Use this device only with copper or copper clad wire.
- INDOOR USE ONLY

DESCRIPTION:

The IOS-HB-U occupancy sensor is designed for automatic lighting control in high bay applications, such as warehouses, distribution centers, gymnasiums, and areas with direct access to the lighting fixtures, specifically for indoor locations. This product contains a passive infrared sensor (PIR) and is made up of two parts: a control module and a lens.

MOUNTING THE SENSOR

The IOS-HB-U can attach to a fixture or junction box. Follow this procedure to mount the sensor to the junction box or fixture. A customer-supplied junction box with 1/2 inch knockout or fixture is needed to complete this procedure.

1. Turn off power at the circuit breaker.
2. Determine the mounting location appropriate to the control and the coverage area.
3. Punch out the cap in the 1/2 inch knockout on the junction box.
4. Remove the nut from the occupancy sensor nipple. Set aside nut for re-use.
5. Insert the nipple into the junction box or fixture.
6. Pull the wires from the nipple through the junction box and secure the connection with the nut.

INSTALLATION

NOTE: Be sure there are no objects, such as an edge of a fixture or shelving, that obstruct the sensor's line of sight.

1. Mount the sensor below the edge of the fixture, away from the fluorescent lamps so that the heat from the lamps does not affect the sensor.
2. Connect the line voltage as show in Figure 4.

NOTE: Make sure all connections are secure and the bare wire is not exposed.

3. Connect the Hot wire to the Black wire from the sensor
4. Connect the Neutral wire to the White wire from the sensor
5. Connect the Load wire to the Red wire from the sensor
6. Attach the sensor as shown in Figures 5 and 6.
7. Restore power from the circuit breaker.

INITIAL OPERATION OF SENSOR AFTER POWER UP

Upon the initial sensor power up, there is a minute warm-up period. The sensor LED flashes to indicate the sensor warm-up. Make sure there is no movement in the sensor coverage area during power up. If the sensor detects motion during the warm-up, the time delay will increase.

ADJUST THE LIGHT LEVEL

The Light Level feature enables the user to adjust the brightness requirements for the coverage area before the sensor turns the lights ON. Remove the cover from the sensor and adjust the lighting from the light level dial on the sensor (see Figure 8). You can set the dial anywhere between + or - to obtain the optimal brightness configuration for the room (see Figure 7).

LENS INSTALLATION

1. Determine which lens is required. (see Figures 1 & 2)
2. Lens simply snaps into place.

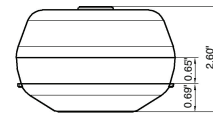
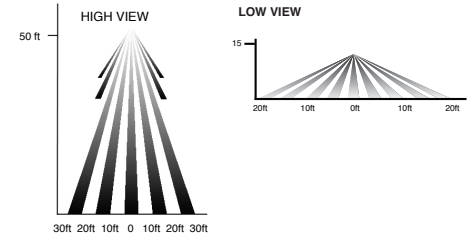

Lens A
Sensor including
backbox and lens
Figure 1

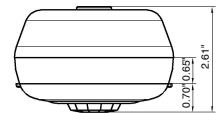

Lens B
Sensor including
backbox and lens
Figure 2

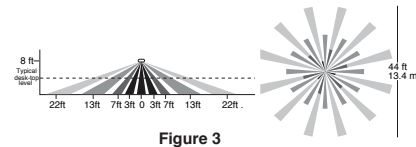

Figure 3

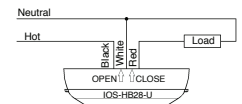

Figure 4

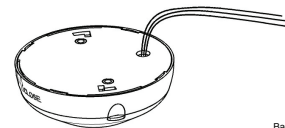

Figure 5

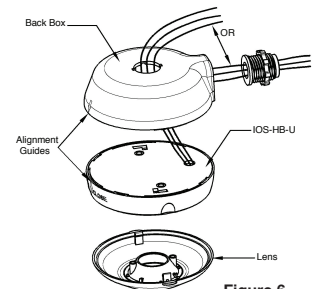

Figure 6



Light
Figure 7

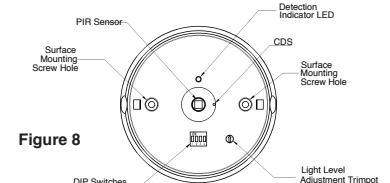

Figure 8

ADJUSTING THE SENSOR DIP SWITCH SETTINGS

The occupancy sensor features 4 DIP switches, one sensitivity setting and three time delay settings. Each setting can be set to an up position or down position that configures the DIP Switch setting to a specified sensitivity or time delay. Follow this procedure to adjust the DIP switch settings.

1. Adjust the sensitivity level DIP Switch (1). The Up position sets the sensitivity to 100%, while the down position adjusts the sensitivity level to 50%.
2. Adjust the time delay DIP switches (2-4). Refer to the table below to set a time delay.

NOTE: After the sensor detects no motion in the coverage area, it will delay a user-configured amount of time before turning lights off. See the table below to determine how to set the desired time delay for the sensor.

3. Install the front on the sensor and secure with the screws.

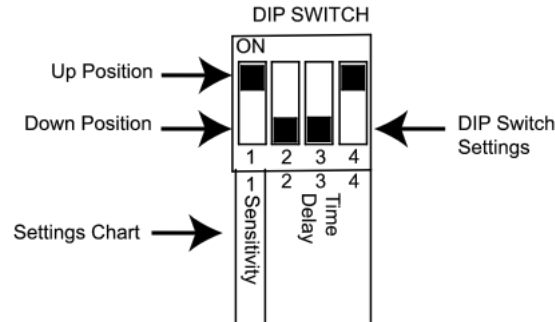

FIGURE 9. Configuring DIP Switch Settings

Time Delay Option	Slide 2 Switch Setting to	Slide 3 Switch Setting to	Slide 4 Switch Setting to
Set for 15 Seconds	Down Position	Down Position	Down Position
Set for 5 Minutes	Down Position	Down Position	Up Position
Set for 10 Minutes	Down Position	Up Position	Down Position
Set for 15 Minutes	Down Position	Up Position	Down Position
Set for 20 Minutes	Up Position	Down Position	Down Position
Set for 25 Minutes	Up Position	Down Position	Up Position
Set for 30 Minutes	Up Position	Up Position	Down Position.

TROUBLESHOOTING

LED flashes but lights do not turn ON:	<p>Make sure wiring is correct.</p> <p>Make sure that the power to the sensor has been ON continuously for 1 minute.</p> <p>Cover the light sensor lens to simulate darkness. If light turns ON adjust the light level.</p> <p>Check the light fixture.</p>
Lights will not turn OFF:	<p>Make sure other sources of infrared energy in the area, such as turbulent air from a heating or cooling supply, are not causing the sensor to detect motion. Adjust accordingly.</p> <p>Verify the time delay DIP switches are set properly.</p> <p>Check sensor wiring.</p>

LIMITED TWO YEAR WARRANTY

If within the warranty period specified, this product fails due to a defect in material or workmanship, Intermatic Incorporated will repair or replace it, at its sole option, free of charge. This warranty is extended to the original purchaser only and is not transferable. This warranty does not apply to: (a) damage to units caused by accident, dropping or abuse in handling, acts of God or any negligent use; (b) units which have been subject to unauthorized repair, opened, taken apart or otherwise modified; (c) units not used in accordance with instructions; (d) damages exceeding the cost of the product; (e) sealed lamps and/or lamp bulbs, LED's and batteries; (f) the finish on any portion of the product, such as surface and/or weathering, as this is considered normal wear and tear; (g) transit damage, initial installation costs, removal costs, or reinstallation costs.

INTERMATIC INCORPORATED WILL NOT BE LIABLE FOR INCIDENTAL OR CONSEQUENTIAL DAMAGES. SOME STATES DO NOT ALLOW THE EXCLUSION OR LIMITATION OF INCIDENTAL OR CONSEQUENTIAL DAMAGES, SO THE ABOVE LIMITATION OR EXCLUSION MAY NOT APPLY TO YOU. THIS WARRANTY IS IN LIEU OF ALL OTHER EXPRESS OR IMPLIED WARRANTIES. ALL IMPLIED WARRANTIES, INCLUDING THE WARRANTY OF MERCHANTABILITY AND THE WARRANTY OF FITNESS FOR A PARTICULAR PURPOSE, ARE HEREBY MODIFIED TO EXIST ONLY AS CONTAINED IN THIS LIMITED WARRANTY, AND SHALL BE OF THE SAME DURATION AS THE WARRANTY PERIOD STATED ABOVE. SOME STATES DO NOT ALLOW LIMITATIONS ON THE DURATION OF AN IMPLIED WARRANTY, SO THE ABOVE LIMITATION MAY NOT APPLY TO YOU.

This warranty service is available by either (a) returning the product to the dealer from whom the unit was purchased, or (b) completing a warranty claim on line at www.intermatic.com. This warranty is made by: Intermatic Incorporated, Customer Service 7777 Winn Rd. Spring Grove, Illinois 60081-9698. For warranty service go to: <http://www.intermatic.com> or call 815-675-7000.