



180, 3^e Avenue, L'Islet, Québec, G0R 2C0, CANADA
 Tél.: (418) 247-3947, 1-800-463-7043, Fax: (418) 247-7801
www.ouellet.com

INSTALLATION INSTRUCTIONS 120V Preassembled Self-Regulating Heating Cable



Risks of electrical shocks and fire



WARNINGS AND CAUTIONS

For safe installation and efficient performance of this system, read the instruction manual thoroughly and keep it handy.

Where applicable, installation must meet requirements of the following codes:

- Canadian Electrical Code
- National Electrical Code
- Any other applicable local and/or national code

Where required by law, this product must be installed by a qualified person.

To prevent any possibility of electrical shocks, the power supply must be turned off before handling the heating cables.

CABLE DESCRIPTION

120V preassembled self-regulating heating cables are designed to provide freeze protection for metal and plastic pipes, and de-icing protection for roofs and gutters, in both residential and commercial applications. Because they are self regulating, the cables can be overlapped during installation.

They are available in lengths of 6, 12, 18, 25, 50, 75 and 100 ft. and are fitted with a 30 in. (76 cm) power cord.

PRODUCT SPECIFICATIONS:

Power output

	6 ft.	12 ft.	18 ft.	25 ft.	50 ft.	75 ft.	100 ft.
Nominal power output in air condition at 5 °C (40 °F) (Watts)*	42	84	126	175	350	525	700

* Because of the cable's self-regulating properties, the power density can reach up to 11 Watts per foot when buried in snow or ice: "wet density".
 In this situation, use of a 15 Amp. circuit breaker is valid for all models

Cable specifications

Nominal voltage	120V
Cold lead length	36" (0.9 m)
Outer jacket	Thermoplastic
Bus wire	Nickel plated copper
Minimum installation and start-up temperature	-25 °C (-13 °F)
Maximum operating temperature (power on)	60 °C (140 °F)
Maximum operating temperature (power off)	80 °C (176 °F)
Minimum bend radius	1 in. (25 mm)
Certification	CSA C US 2547790
Rating	Wet rated, for outdoor use (WS)
Warranty	1-year basic warranty on the heating cable 10-year limited warranty available

KIT CONTENTS

- One (1) 120V preassembled self-regulating heating cable
- One (1) pipe label

Upon receipt of the equipment, check the integrity of the heating cable and compare its length with that shown on the box.

Note: We recommend testing the product's insulation resistance.
 The resistance between the cable lead wires and the metal casing should not be below 20 MOhms.

METAL AND PLASTIC PIPE FREEZE PROTECTION



ITEMS REQUIRED FOR METAL AND PLASTIC PIPE FREEZE PROTECTION BUT NOT SUPPLIED:

- Stainless steel or plastic fastener.
- Self-adhesive glass fiber or aluminum tape.
- Extra warning label.
- Ground fault protection device.

INSTALLATION ADVICE AND RECOMMENDATIONS

The following recommendations are intended as basic guidelines for any proper installation of eltherm® self-regulating heating cables for pipes and gutters.

Protective measures:

- A ground fault protection device (30 mA, or a fault level 30 mA higher than that of the installation) must be installed for each heating circuit.
- Turn off all power to the circuits before installation or before performing maintenance on the heating elements.
- All work must be carried out in compliance with all prevailing codes and regulations

INSTALLATION INSTRUCTIONS

Before installing the heating cable, please read the following recommendations:

- Remove any sharp objects on the surface to be heated.
- Clean and degrease the surface.
- Maintain minimum of 1 in. (25 mm) bend radius with any of the cables.

Attaching the heating cable to pipes:

- Use self-adhesive glass fiber tape or stainless steel fasteners to secure the cable. Plastic cable ties (such as Ty-Rap) can also be used. Secure cable at 12 in. (30 cm) intervals.
- CAUTION: Do not use adhesive tape with emollients (e.g. PVC).
- For installation on plastic pipes, we strongly recommend attaching aluminum foil to the pipe before installing the cable. Aluminum allows for better conductivity and heat transfer.
 - Any excess cable can be wound around the pipe.

If the cable is the same length as the pipe:

Run the cable straight along the bottom of the pipe.

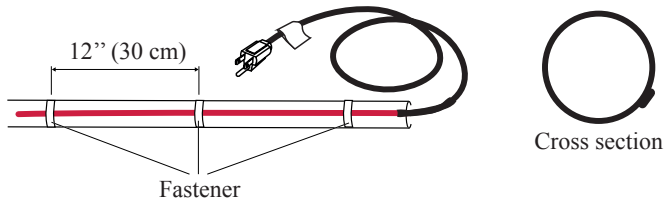

If the cable is double the pipe length:

Run the cable straight to the end of the pipe, then loop back and run it back to the starting point, placing both traces along the bottom of the pipe.



If the cable is longer than the pipe but less than double its length:

Spiral the cable around the pipe

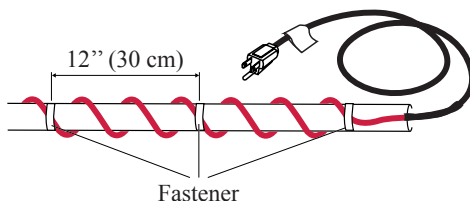

Attaching the heating cable to valves:

- Allow 12 in. (30 cm) of extra cable for each valve.

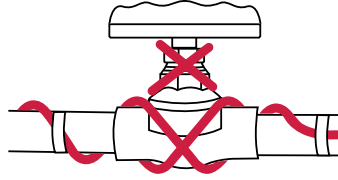

Installing thermal insulation:

- Before insulating, check the cable for mechanical or electrical damage.
 - Cover the pipes with at least 1/2 in. (12.7 mm) thick glass fiber insulation or fire-resistant preformed foam. **DO NOT LEAVE THE HEATING CABLE EXPOSED.**
- Note:** The heating cable must be securely fixed to the pipe to prevent the insulation material from sliding between the cable and the surface to be heated.
- Labelling: electrically heated pipes must be clearly labelled with "Electric Heat Tracing" warning labels placed on the outside of the insulation at suitable intervals (approximately every 15 ft. (5 m) or at least one label on each bypass pipe).

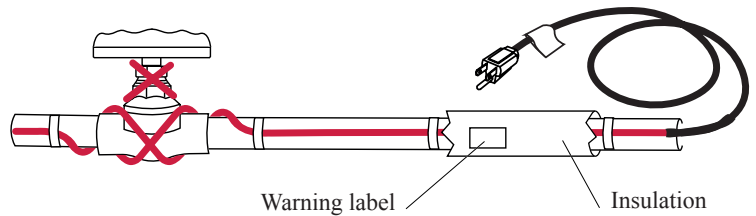

Starting the system:

- Once installation is complete, plug the cable into a 120V outlet fitted with a ground fault protection device (GFCI).
- One (1) hour after turning on, open the water tap and check that the water coming out is warm.
- Heating cables do not generally need any maintenance. However, we recommend that qualified personnel should periodically check the insulation resistance and for signs of damage.

ROOF AND GUTTER DE-ICING SYSTEM



ITEMS REQUIRED FOR ROOF AND GUTTER DE-ICING BUT NOT SUPPLIED:

- Downspout mounting plate.
- Gutter mounting plate
- Roof clip for cable.

INSTALLATION ADVICE AND RECOMMENDATIONS

The following recommendations are intended as basic guidelines for any proper installation of eltherm® self-regulating heating cables for pipes and gutters.

Protective measures:

- A ground fault protection device (30 mA, or a fault level 30 mA higher than that of the installation) must be installed for each heating circuit.
- Turn off all power to the circuits before installation or before performing maintenance on the heating elements.
- All work must be carried out in compliance with all prevailing codes and regulations.

INSTALLATION INSTRUCTIONS

Before installing the heating cable, please read the following recommendations:

- The installation method and layout are determined by the type of roof.
- Ensure the roof and gutters are free of all debris.
- Maintain minimum of 1 in. (25 mm) bend radius with any of the cables.

Shingle roof installation:

Cables should be installed in a serpentine (zig-zag) pattern with tracing widths of approximately 24 in. (610 mm) for normal and moderate snowfall conditions.

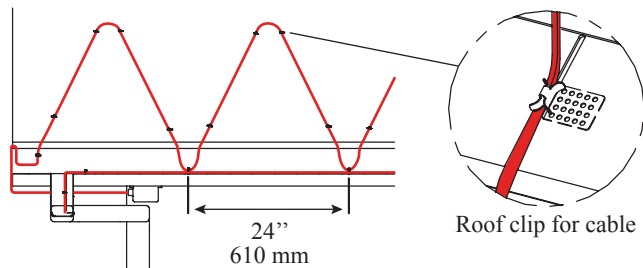

Corrugated metal roof installation:

Cables should be installed parallel to the standing seams or along the seams of a corrugated section.

IMPORTANT: Never exceed the 1 in. (25 mm) bending radius of the cable.

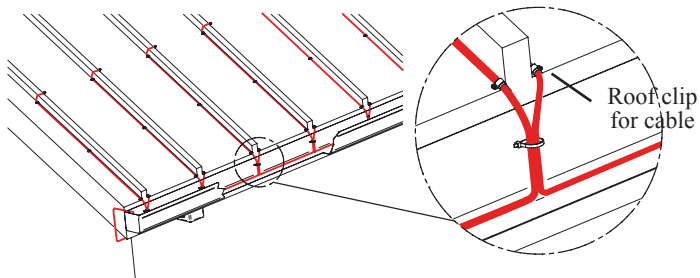

Drainage channels and drip loops:

Allow extra cable to create drainage channels into the gutter and extend beyond the roof to create drip loops. Drip loops should be 2-3 in. (50-76 mm) long.

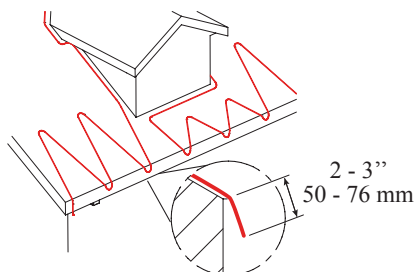

Gutters:

Plan for a single trace of cable for gutters less than 6 in. (152 mm) wide and two traces (measure two gutter lengths) for gutters 6 in. wide or larger.

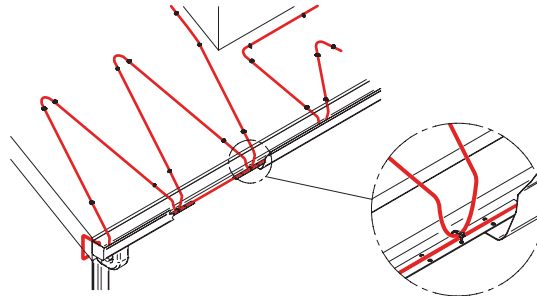

Downspouts:

We recommend an additional 12 in. to 18 in. (305 mm to 455 mm) of cable for end termination to be located back-up into downspout.

For downspouts directly connected to sewers, extend the heating cable under the ground near the horizontal drain.

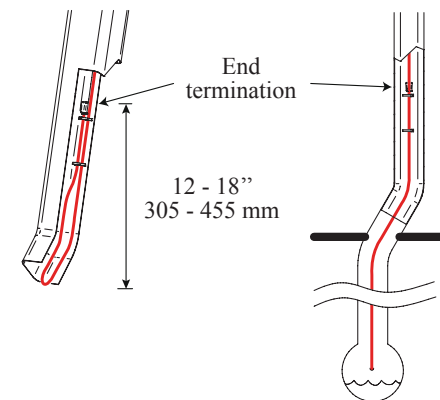

Roof valleys:

Ice sometimes forms on a roof at the junction where two slopes meet. To create a continuous path for meltwater runoff, run the cable 2/3 up and down the valley, as shown in the figure below.

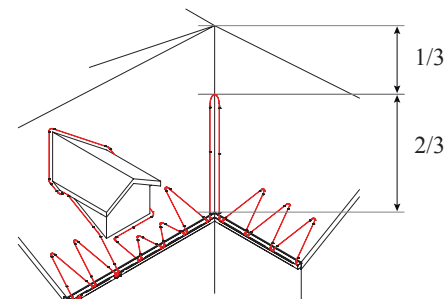

Starting the system:

- The system should only be switched on once ice has accumulated on the roof.
- Plug the cable into a 120V outlet fitted with a ground fault protection device (GFCI).
- Turn the power off when ice has disappeared from the roof.
- Heating cables do not generally need any maintenance. However, we recommend that qualified personnel should periodically check the insulation resistance and for signs of damage.