

# Raychem FTC-HST

## XL-TRACE, RAYSOL, AND ICESTOP SPLICE/TEE CONNECTION KIT INSTALLATION INSTRUCTIONS

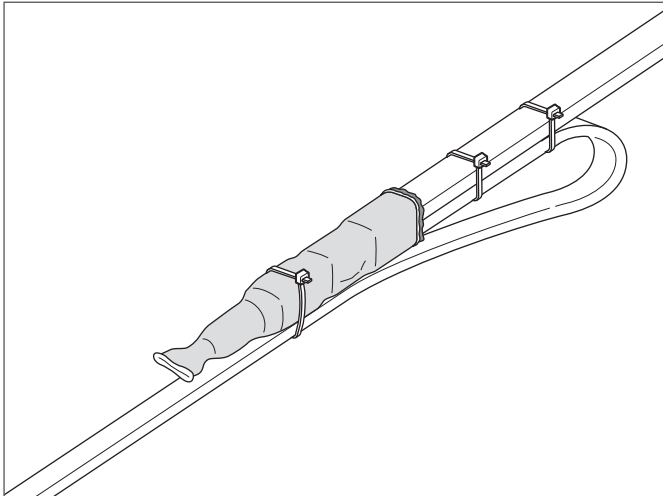

### DESCRIPTION

The Raychem FTC-HST is used with RaySol system heating cables to make splice connections (on slab bottoms only), and with IceStop and XL-Trace systems to make splice and tee connections. Materials for 2 splice or tee connections are included in each kit. These installation instructions should be used in conjunction with the RaySol, IceStop and XL-Trace System Installation and Operation Manuals. For technical support contact your Pentair Thermal Management representative or call Pentair Thermal Management at (800) 545-6258.

### TOOLS REQUIRED

- Diagonal cutters
- Utility knife
- Crimp tools (Ideal 30-425 and T&B WT112M or WT2000)
- Hammer and nail (for IceStop gutter/downspout applications only)
- Needle nose pliers
- Heat gun or torch

**IMPORTANT:** First verify heating cable is appropriate for the application. The cable type is printed on the outer jacket:

- IceStop: Roof and gutter de-icing
- XL-Trace: Above ground pipe freeze protection
- RaySol: Floor warming

The minimum installation temperature for the FTC-HST splice and tee is 0°F (-18°C).

### ADDITIONAL MATERIALS REQUIRED

When using FTC-HST as a tee kit, a RayClic-E is required.

### APPROVALS



718K Pipe Heating Cable or 877Z De-Icing and Snow-Melting Equipment or 9J86 Radiant Heating Cable



Certified with XL-Trace, IceStop and RaySol heating cables



For 12XL2-CT, -CR only



**With XL-Trace and IceStop heating cables only**  
For Class I, Div. 2, Groups A, B, C, D hazardous locations-GM-1XT and GM-2XT only

### KIT CONTENTS

Item	Qty	Description
A	4	Insulated bus wire crimps
B	2	Uninsulated braid crimps
C	6	Cable ties
D	12	Mastic strips
E	2	Heat-shrinkable caps
F	2	Heat-shrinkable tubes (6 in long, 1 in dia.)
G	2	Black cloth tapes (6 in long)
H	2	Clamp ties

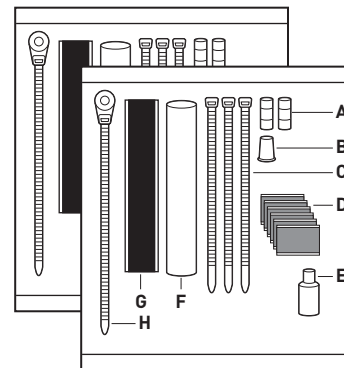

### WARNING:

This component is an electrical device that must be installed correctly to ensure proper operation and to prevent shock or fire. Read these important warnings and carefully follow all the installation instructions.

- To minimize the danger of fire from sustained electrical arcing if the heating cable is damaged or improperly installed, and to comply with the requirements of Pentair Thermal Management, agency certifications, and national electrical codes, ground-fault equipment protection must be used. Arcing may not be stopped by conventional circuit breakers.

- Bus wires will short if they contact each other. Keep bus wires separated.
- Keep components and heating cable ends dry before and during installation.
- The black heating cable core is conductive and can short. It must be properly insulated and kept dry.
- Component approvals and performance are based on the use of Pentair Thermal Management-specified parts only. Do not use substitute parts or vinyl electrical tape.
- Leave these instructions with end user for reference and future use.

### CAUTION:

**HEALTH HAZARD:** Overheating heat-shrinkable tubes will produce fumes that may cause irritation. Use adequate ventilation and avoid charring or burning. Consult MSDS RAY3122 for further information.

CHEMTREC 24-hour emergency telephone:  
800-424-9300.

Non-emergency health and safety information:  
800-545-6258.

Instructions are shown for a tee connection. Splice connections are done the same way, without the third heating cable section.

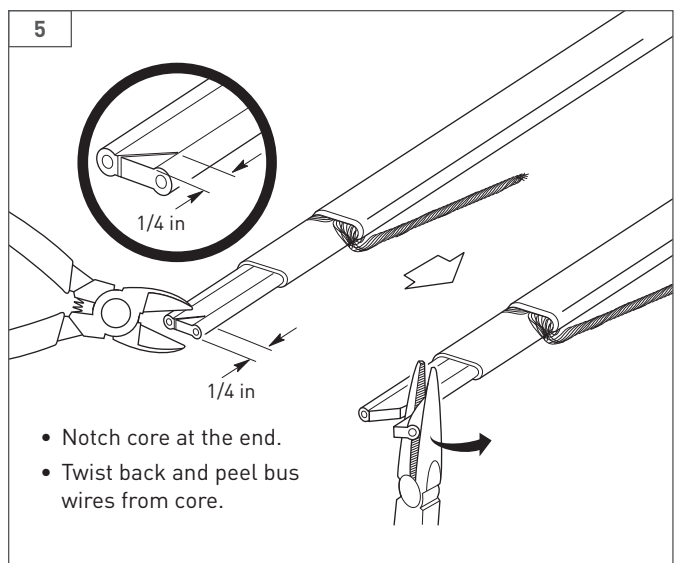
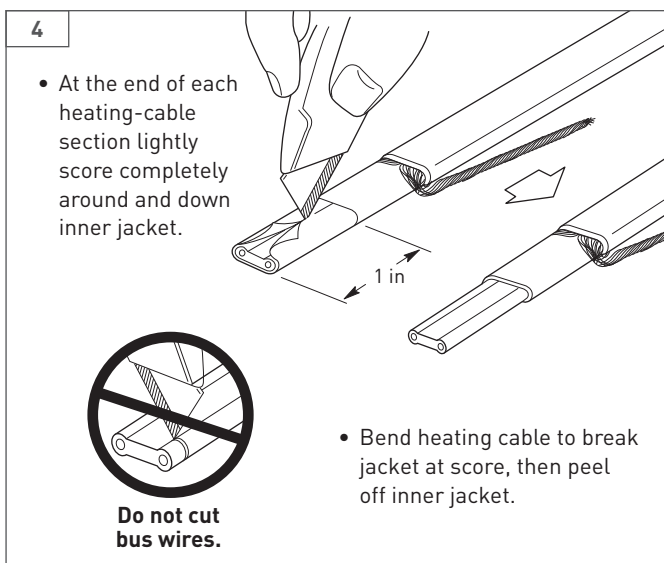
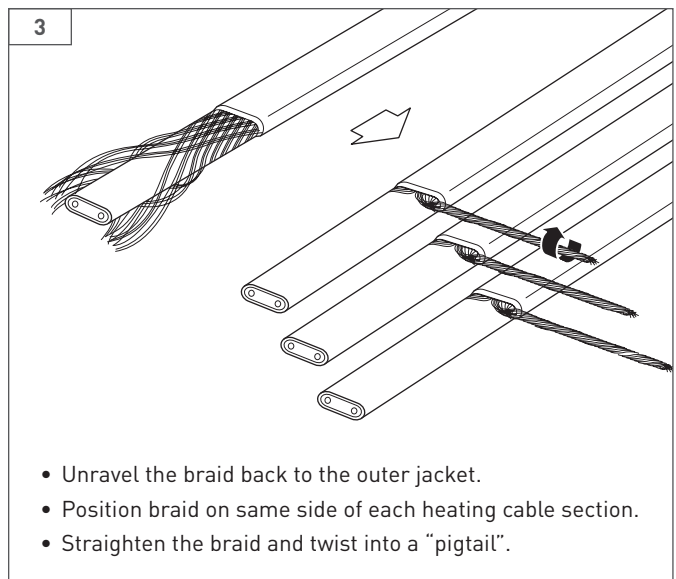
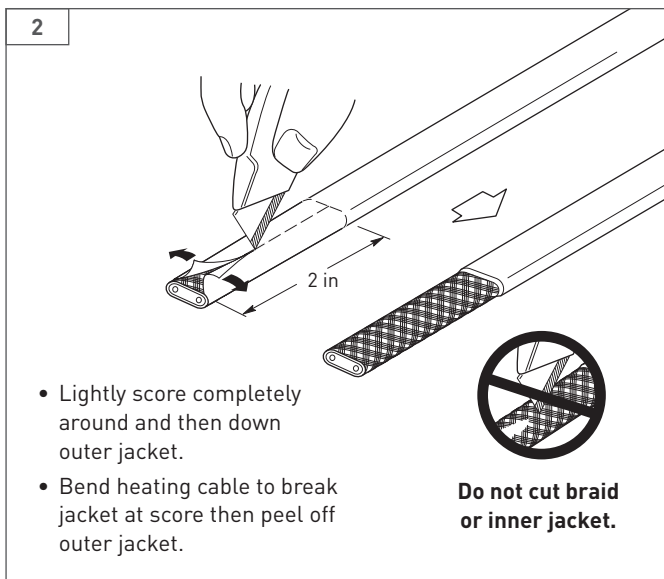
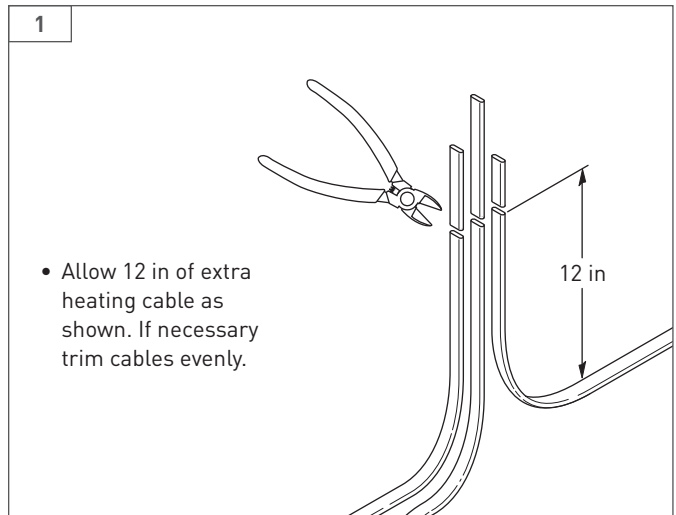
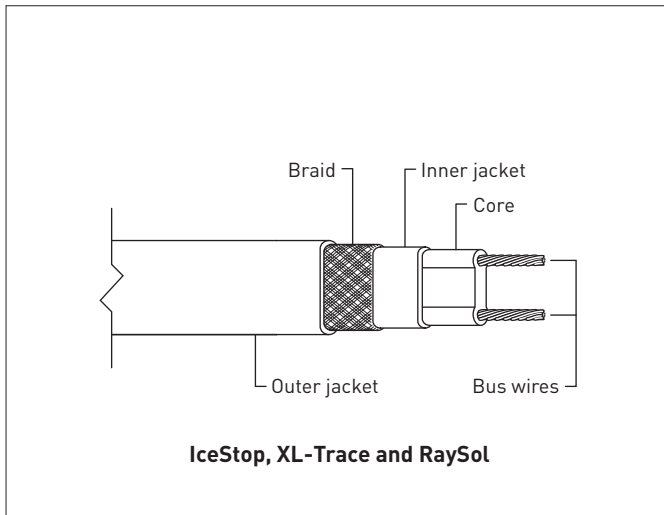

6

- Score between bus wires at base jacket.
- Bend core to break free at base jacket.



Do not cut bus wires.

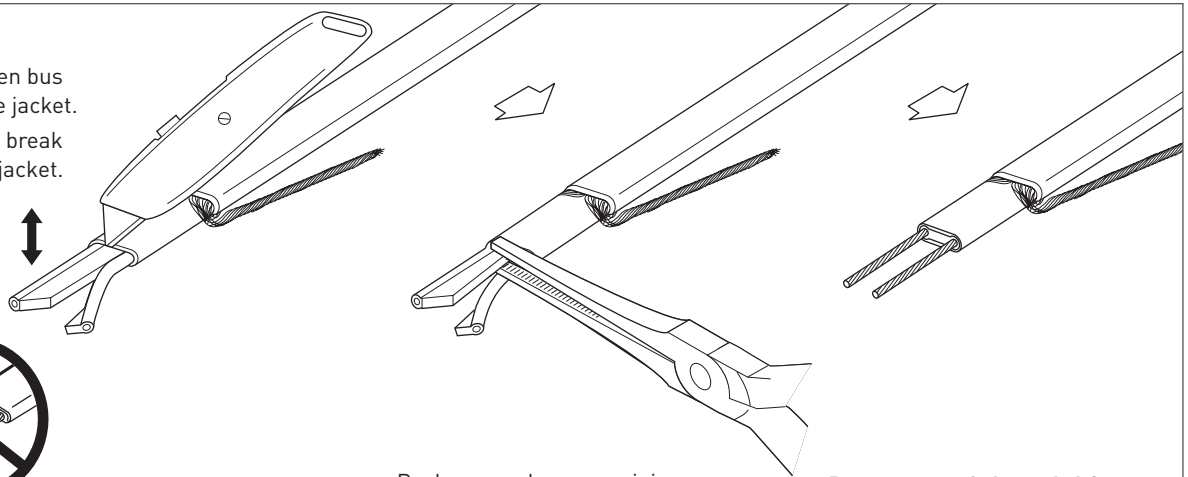

- Peel core and any remaining material from bus wires.

Repeat steps 2 through 6 for other heating cable sections.

7

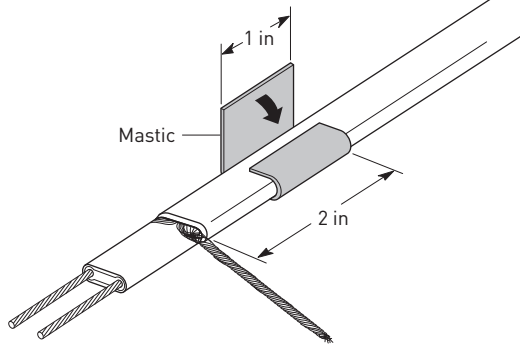

- Remove release paper from mastic strip.
- Wrap a piece of mastic around the outer jacket on each heating cable section.

8

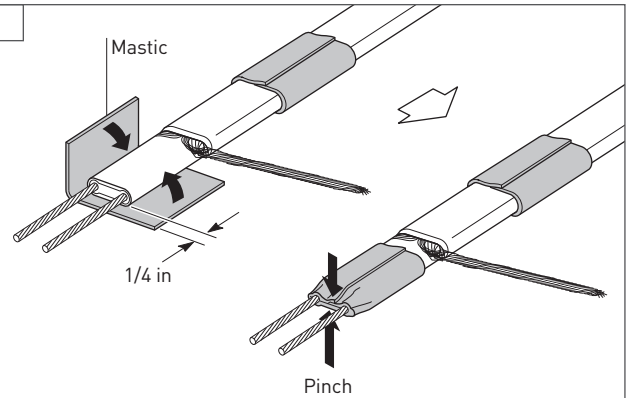

- Remove release paper from mastic strip.
- Wrap a piece of mastic around the end of each heating cable section and position as shown.
- Pinch the mastic in the center to completely seal the core at the end of each heating cable.

9

- Carefully align the heating cable sections and place them together.
- Press mastic strips firmly together.

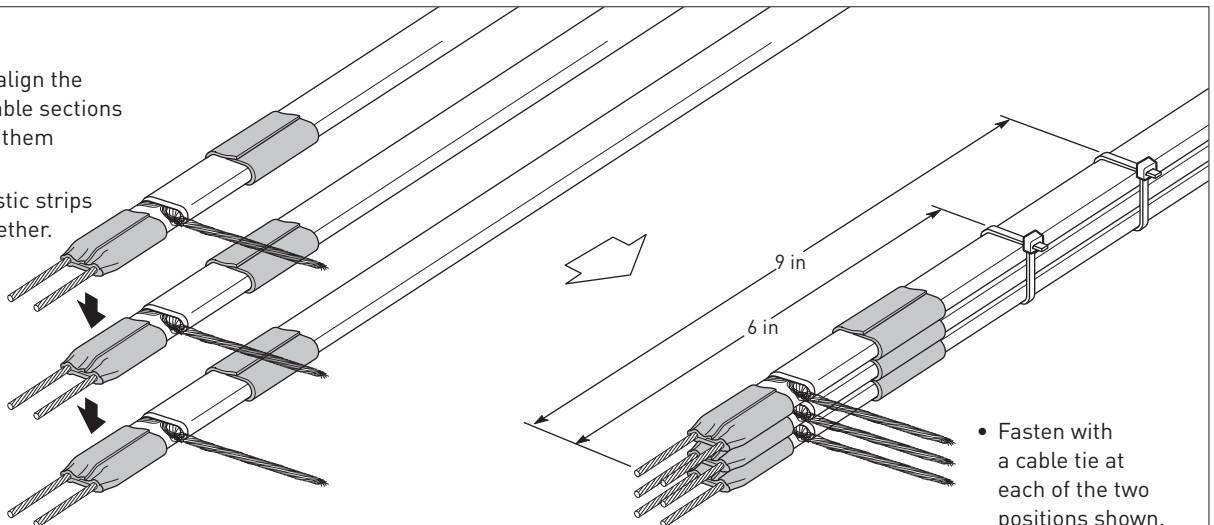

- Fasten with a cable tie at each of the two positions shown.

10

- Twist the braid pigtails together.

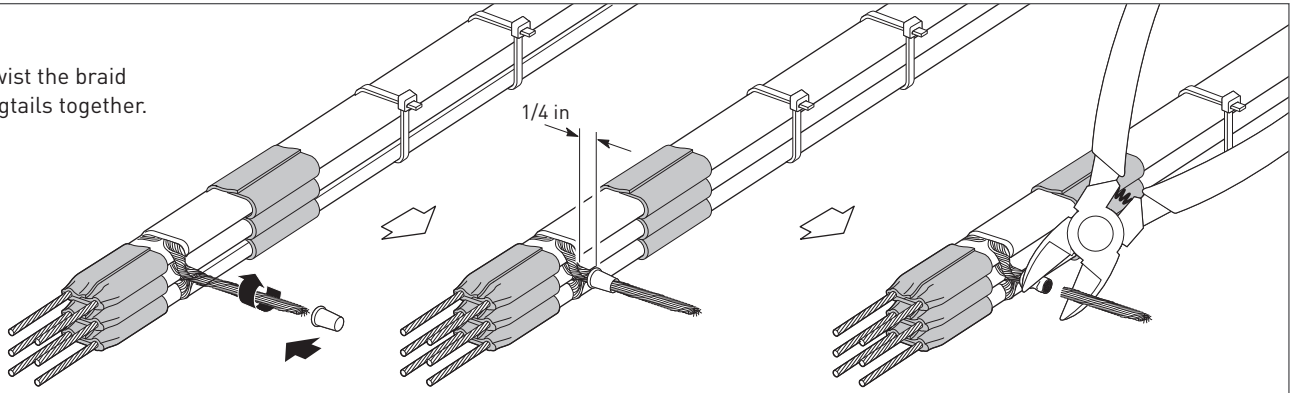

- Slide insulated crimp over braid to within 1/4 in of heating cable as shown.

- Crimp the braid, using the Ideal crimp tool.

- Cut off the extra braid.

11

Black tape

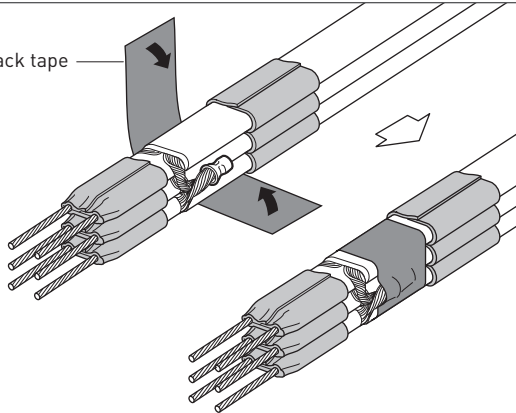

- Fold the crimped braid back against the heating cables.
- Wrap black cloth tape evenly around crimp and heating cables. Cover crimp completely.

12

- Select one bus wire from each cable section and twist the wires together.

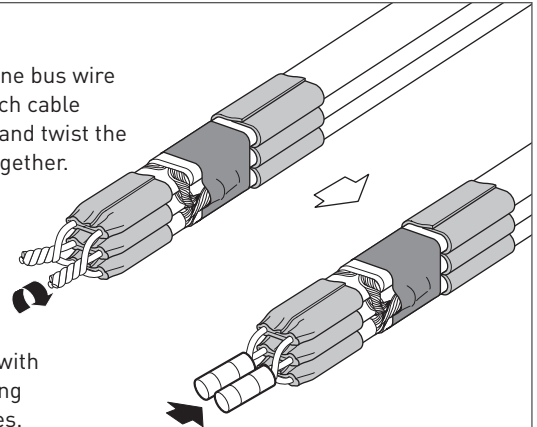

- Repeat with remaining bus wires.

**Be careful not to twist together bus wires from the same heating cable.**

- Use insulated bus wire crimps and T&B crimp tool to crimp each set of bus wires together.

13

- Slide heat-shrinkable cap over bus wire crimps.
- It is not necessary to shrink cap.

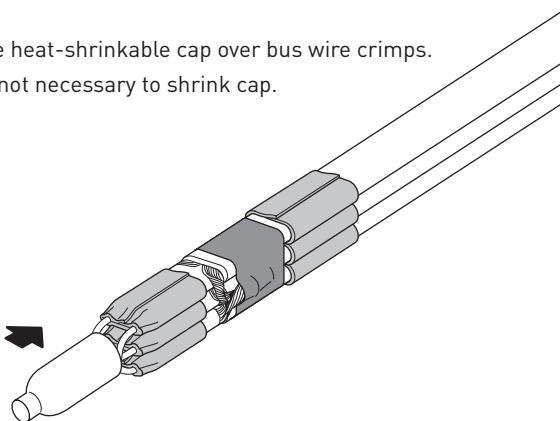

14

- Position the 6-inch-long heat-shrinkable tube as shown.

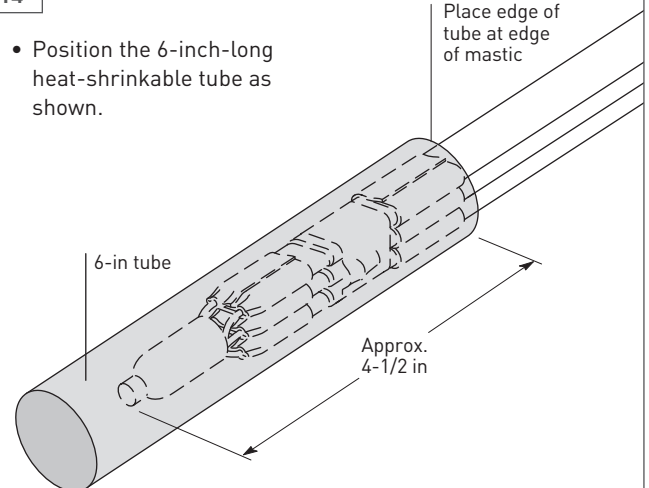

15

- Shrink the tube completely. Start at end farthest from the cap and work toward the open end.
- Keep heating after tube has shrunk, to melt adhesive and mastic inside tube. Total heating time should be about 5 minutes.

Ring of mastic and adhesive will appear

**Important:** Additional heat is needed after the tube is shrunk to melt mastic and adhesive inside.

• Immediately after shrinking, pinch the end of the tube with needle-nose pliers until the end stays sealed; this normally takes 10 seconds.

**CAUTION: Health Hazard.** Consult material safety data sheet RAY3122.

**CAUTION: To avoid burns allow heated sections to cool before touching.**

16A For all applications except IceStop in gutters and downspouts

Secure end of connection to heating cable

- After the connection has cooled, fold over the connection and fasten it with the third cable tie.

16B IceStop gutter and downspout applications

GM-RAKE

- Secure heating cable with down-spout hanger (GM-RAKE).
- Fasten clamp tie to center of connection.
- Use a hammer, nail, and clamp tie to secure connection and keep it off of the gutter bottom as shown.

16C For RaySol splice applications in conduit



[WWW.THERMAL.PENTAIR.COM](http://WWW.THERMAL.PENTAIR.COM)

**NORTH AMERICA**

Tel: +1.800.545.6258  
Fax: +1.800.527.5703  
Tel: +1.650.216.1526  
Fax: +1.650.474.7711  
[thermal.info@pentair.com](mailto:thermal.info@pentair.com)

**EUROPE, MIDDLE EAST, AFRICA**

Tel: +32.16.213.511  
Fax: +32.16.213.603  
[thermal.info@pentair.com](mailto:thermal.info@pentair.com)

**ASIA PACIFIC**

Tel: +86.21.2412.1688  
Fax: +86.21.5426.2917  
[cn.thermal.info@pentair.com](mailto:cn.thermal.info@pentair.com)

**LATIN AMERICA**

Tel: +55.11.2588.1400  
Fax: +55.11.2588.1410  
[thermal.info@pentair.com](mailto:thermal.info@pentair.com)

Pentair, RaySol, IceStop and XL-Trace are owned by Pentair or its global affiliates. All other trademarks are the property of their respective owners. Pentair reserves the right to change specifications without prior notice.