

## Installation, Operation, and Maintenance Guide

### For indoor/outdoor dry-type transformers which utilize DH series, NH series CN Series or NJ1, NJ2, NJ3, NJ4 type enclosures.

This manual covers the recommendations for the installation, operation and maintenance of dry-type low voltage transformers. It is emphasized that these abbreviated instructions should be used in conjunction with all local and National codes and should be referenced accordingly.

	Page
Warnings	2
Safety Instructions	3
General	4
Handling	4
Receiving & Inspection	4
Storage	5
Installation	5
Ventilation	6
Accessibility	7
Transformer Sound Levels	7
Cable Connections	8
Grounding	9
Altering the Transformer	9
Before Energization	10
Operation	10
Maintenance	11
Dry-out of Transformers	12
Accessories	12



*The pictures used in this guide are only a representation and may vary from the actual product.*

#### *Disclaimer of Liability*

*The recommended practices in this manual are for general applications and are supplied without liability for errors or omissions. Technical data are subject to change at any time without notice and any necessary corrections will be included in subsequent editions.*



*Special requirements should be referenced back to the manufacturer and/or their representative.*

This guide covers the recommendations for the installation, operation and maintenance of VPI indoor/outdoor dry-type transformers which utilize DH, NH, NJ or CN type enclosures. It is emphasized that these abbreviated instructions should be used in conjunction with all standards and local codes covering such work and should be referenced accordingly.

These recommended practices are for general applications and any special requirements should be referenced back to the transformer manufacturer and/or their representative.

It is further recommended that installation work be governed by all applicable National, State and Local codes standards and regulations and ANSI/IEEE C57.94. This is the IEEE recommended practice for Installation, Application, Operation and Maintenance of Dry-type General Purpose Distribution and Power Transformers. All work should be performed in accordance with NFPA 70E Standard for Electrical Safety in the Workplace and CSA Z462, Workplace Electrical Safety. Always use appropriate personal protective equipment (PPE).

This manual contains warnings to observe in order to ensure personal safety and prevent property damage. Read these instructions carefully and look at the equipment to become familiar with the device before trying to install, operate, service or maintain it. The notices referring to personal safety are highlighted in the manual by a safety alert symbol, notices referring only to property damage have no safety alert symbol. These notices shown below are graded according to the degree of danger. If more than one degree of danger is present, the warning representing the highest degree of danger will be used.

	<b>DANGER</b> DANGER indicates an imminently hazardous situation which, if not avoided, will result in death or serious injury, and/or substantial property damage.
	<b>WARNING</b> WARNING indicates a potentially hazardous situation which, if not avoided, can result in death or serious injury, and/or substantial property damage.
	<b>CAUTION</b> CAUTION indicates a potentially hazardous situation which, if not avoided, can result in minor or moderate injury and/or property damage.

**Important Note:**

Electrical equipment should be installed, operated, serviced, and maintained, only by qualified personnel. No responsibility is assumed by the manufacturer for any consequences arising out of the use of this material.

## Safety Precautions



### DANGER

#### HAZARD OF ELECTRIC SHOCK, EXPLOSION OR ARC FLASH

Refer to nameplate for ratings and voltages.  
This equipment must only be installed and serviced by qualified electrical personnel.  
Follow all requirements in NFPA 70E and CSA Z462 for safe work practice and personal protective equipment (PPE).  
Turn off all power supplying this equipment before working on or inside equipment.  
Always use a properly rated voltage sensing device to confirm power is off.  
Replace all devices, doors, and covers before turning on power to this equipment.

**Failure to follow these instructions will result in serious injury or death.**

1. Do not lift or move a transformer without proper equipment and properly trained personnel. Ensure that the transformer is only lifted using the listing provisions provided. Always use lifting provisions provided by the manufacturer. Rolling and skidding are recommended only on transformers with a pre-ordered skidding base.
2. Do not off-load the transformer until it has been fully inspected for damages. If any damages are identified the transformer should not be energized and HPS customer service should be contacted immediately, Canada 1-888-798-8882 and USA 1-866-705-4684.
3. Only use terminals for electrical connections. Flexible connectors are recommended for bus connections. The transformer terminals are not designed to support the weight of line or load cable. Uni-strut supports can be added in the field providing proper clearances are maintained.
4. Connections should only be made in accordance with the nameplate diagram or connection drawings and the applicable local codes and standards.
5. Make sure all power (including back-fed control and possible capacitor charge) is disconnected and all windings are grounded before attempting any work on the transformer or inside the enclosure.
6. Make certain all ground connections, line terminals and selected tap connections are completed and tightened before energizing the transformer.
7. Do not attempt to change any primary or secondary connections or taps while the transformer is energized.
8. Do not tamper with control panels, alarms, interlocks, or control circuits.
9. Do not adjust or remove any accessories or cover plates while the transformer is energized.
10. No cables should come in contact with the core or coil or any live parts except the terminal that it is intended for. Ensure that minimum clearances are maintained at all times. (refer to Field Testing section)
11. This equipment must only be installed and serviced by qualified electrical personnel.
12. Follow all requirements in NFPA 70E and CSA Z462 for safe work practice and personal protective equipment (PPE).
13. Replace all devices, doors, and covers before turning on power to this equipment.
14. In the case of work being performed around the transformer that might result in foreign objects falling inside the core and coil assembly, after de-energizing the transformer, cover the core and coil with a suitable protective drop cloth. The drop should be removed and the transformer visually inspected for any foreign objects before re-energizing the transformer.
15. Modifications of any kind to the equipment are not permitted. Beside voiding the warranty such actions may result in hazardous situations of which the person(s)

## General



### DANGER

#### HAZARD OF ELECTRIC SHOCK, EXPLOSION OR ARC FLASH

Refer to nameplate for ratings and voltages. This equipment must only be installed and serviced by qualified electrical personnel. Follow all requirements in NFPA 70E and CSA Z462 for safe work practice and personal protective equipment (PPE). Turn off all power supplying this equipment before working on or inside equipment. Always use a properly rated voltage sensing device to confirm power is off. Replace all devices, doors, and covers before turning on power to this equipment.

**Failure to follow these instructions will result in death or serious injury.**

performing the modifications will be solely liable.

Dry-type transformers are manufactured to provide optimum performance for a lifetime of uninterrupted service. Careful attention to the following instructions is recommended for safe and reliable operation.

Installation, operation and maintenance of transformers should be performed by authorized personnel, trained and qualified in the installation, repair and maintenance of electrical equipment.

As any other electrical equipment, transformers must be installed according to the requirements of all applicable national and local electrical codes. ANSI/IEEE C57-94 may also be referred to for recommended installation, application, operation and maintenance of dry-type transformers.

### Autotransformers

If the application needs a neutral (including 3 phase 4 wire systems), the autotransformer must be ordered with the optional neutral terminals.

This option will provide the customer with a common (H0/X0) neutral connection point that is connected by the factory to the middle point of the Y winding configuration.

When selecting this option, both the Line and Load side neutral cables must be connected to the respective neutral terminals in order to ensure the proper operation of the autotransformer.

Please refer to the local electrical code requirements for grounding and the short circuit protection of a three phase autotransformer.

## Handling



### WARNING

Failure to follow lifting procedures can result in death, serious injury, or property damage.

Transformers are palletized and can either be lifted via a forklift truck or hoisted by the lifting lugs provided.

Appropriate lifting equipment should be used relative to the size of each transformer. For safety purposes and to protect the transformer, spreader bars are recommended.

No attempt should be made to lift or move a transformer from any points on the unit other than those indicated. Refer to pages 17 to 19. Avoid subjecting transformer to impact, jolting and other rough handling that may damage the transformer.

Ensure the transformers are transported in upright position - avoid tilting and tipping.

## Receiving & Inspection

Immediately after receiving the transformer, it should be inspected for any transit damage and for correctness against the shipping documents.

The unit should be examined for any breaks in its packaging, dented or damaged enclosures or missing parts from the packing list.

If any damage is noted, a claim should be filed immediately with the carrier and a second copy of all pertinent information relative to the order and the circumstances should

be immediately communicated to the local HPS sales office.

If the examination of the unit takes place outdoors, caution should be exercised to protect the unit against factors that may present further hazard.

## Storage



### WARNING

Failure to follow storage requirements can result in death or serious injury, and property damage.

Transformers that will not be immediately installed and energized, should be stored in a clean dry environment away from any environmental airborne contaminants. Transformers should be stored in such a way not to represent any type of hazard. Stacking transformers one on top of another without proper shelving is not permitted.

It is recommended that transformers be stored in a heated building with uniform temperature and adequate air circulation to prevent condensation with the protective plastic wrap still installed for long term storage. If storage in a heated building is not possible, transformers must be properly protected from contaminants and moisture preferably in a non heated building. We recommend that electric heating be installed inside the transformer to maintain a uniform temperature above the ambient and to prevent condensation. In extreme cases they may be stored in temperatures no lower than  $-40^{\circ}\text{C}$  ( $-40^{\circ}\text{F}$ ). Special care should be given to prevent the formation of condensation inside the stored transformers. Units that are to be energized after being stored at a low temperature or after being stored for a long time must be warmed to  $-25^{\circ}\text{C}$  ( $-13^{\circ}\text{F}$ ) with warm air or radiant heat. Once the unit reaches this temperature and its free of condensation and any other contaminants resulting from the storage process, it is safe to be energized.

## Installation



### DANGER

#### HAZARD OF ELECTRIC SHOCK, EXPLOSION OR ARC FLASH

Failure to follow these Installation instructions and all applicable local and national codes when installing and connecting a transformer will result in death or serious injury and/ or substantial property damage.

**Enclosures are designed and approved in accordance with specifications CSA 22.2 No. 47 (General Purpose), CSA 22.2 No. 94 (Specialty Enclosures), NEMA 250 and UL 50.**

**For IEC enclosure equivalents please see IEC 60529 (Enclosure Classifications Designations).**

#### a) Enclosed Indoor/Outdoor Dry-Type Transformers

Most dry-type transformers are supplied with either a type 3R, 4 or 12 enclosure. Units may be installed indoors, or outdoors where applicable. If equipped with a type 1 enclosure, these units are for indoor use only.

Ventilated enclosures are recommended for indoor installation but may also be installed outdoors based on the rating of the enclosure and the recommendations of the Consulting Engineer overseeing the project.

For any outdoor location, the appropriate applicable codes must be followed including cable installation and hardware suitable for outdoor service. Before outdoor installations, verify that adequate site drainage exists to prevent groundwater from entering the transformers.

Water tight couplings are strongly recommended to be installed at the knockouts or any other holes drilled any holes

## **Installation (continued)**

in the enclosure for incoming/ outgoing cables. When drilling holes, the core and coil must be covered with plastic wrap.

Dry-type transformers must be installed in an upright position on walls, floors, posts, beams or other locations capable of supporting their weight with the proper accessories attached. Refer to Appendix B and C (page 15 and 16) for wall mounting kits.

Conventional open ventilated dry-type transformers have a bottom screen for air convection. When transformers are mounted above the ground or over a combustible surface, a 14 gauge catcher plate drip plate should be installed under each transformer as a safety precaution against any hot particles that may fall through the screen in the event of a faulted condition. Refer to Appendix B and C (page 15 and 16).

It is important that ventilated transformers are installed in a dry area where the ambient air is clean. Do not install ventilated transformers in environments with excessive moisture and contaminants including, but not limited to dust, oil, corrosive gasses and other chemical vapors. Transformers should not be installed in such a place having the possibility of water logging inside the enclosure.

In the event that a transformer has been subjected to moisture or dampness before installation, ensure that it is completely cleaned and dried before energization. In this case we recommend blowing warmed air through the transformer to dry internal components. Refer to the section on dry-out of transformers.

### **b) Indoor/Outdoor Transformers with Non-Ventilated Type 4, 4X or 12 Enclosures.**

Transformers equipped with non-ventilated type 4, 4X or 12 enclosures may be located either indoors or outdoors in any similar location noted above. Non-ventilated enclosed transformers, although slightly larger, offer much greater protection against a variety of elements such as dust, dirt, snow, moisture, rain etc.

For any outdoor location, the appropriate applicable codes must be followed including cable installation and use of hardware suitable for outdoor service.

## **Ventilation**



### **WARNING**

Failure to follow the ventilation instructions can result in death, serious injury or property damage.

Transformers are required to be installed in an area where they can be cooled by means of free air circulation with the average ambient temperature of 30°C (86°F) which should not exceed 40°C (104°F) at any time.

Adequate ventilation is essential for transformers to meet their nameplate kVA capability. The distance a transformer should be located away from any wall or any other obstruction is stated on the nameplate.

The minimal distance is required to allow free, clean circulation of air through the ventilation openings or around a non-ventilated unit. No other obstructions, line/ load cables or ventilation blocking structures are allowed in the ventilation space.

Where bottom entry is allowed for cables, the space used

for conduits in the front of the transformer should not obstruct more than 50% of the front ventilation area defined between the bottom plate and the supporting legs. Please see the Cable Connection Requirements section on page 8 for instructions.

---

## **Accessibility**



### **CAUTION**

Failure to follow accessibility instructions can result in injury and/or property damage.

NEC standards require that transformers be accessible for inspection and located accordingly.

However, transformers should not be located in areas where stored items are likely to interfere with either natural air convection or the capability to have them inspected. Passage ways or other areas where people could be exposed to live parts during inspection should also be avoided.

Adequate protection should be provided under any circumstances.

---

## **Transformer Sound Levels**

Transformers are an electrically energized apparatus and by their nature during normal operation will emit a certain level of sound.

Transformers are required to meet NEMA standards for the maximum sound levels permissible. These sound level standards vary from 40 to 67 dB and as such may be an annoyance if located in close proximity to where people work or reside.

Care should therefore be exercised in selecting sites for transformers particularly in sensitive areas like hospitals, classrooms, medical or office facilities.

The following guidelines may be helpful:

- Units should be mounted away from corners or reflecting walls or ceilings.
- Cable or other flexible conduit should be considered to make the incoming/ outgoing connections.
- All dry-type transformers are provided with isolation anti-vibration pads between the core and coil assembly and the enclosure. However, sound absorbing vibration isolators may also be installed between the transformer and its mounting surface.
- Depending on the environment, to reduce noise acoustically absorbing materials could be considered for walls and ceilings around the unit.
- The location of the unit should be as far as practical from areas where sound levels could be considered undesirable.

## Cable Connections



**DANGER**

**HAZARD OF ELECTRIC SHOCK, EXPLOSION OR ARC FLASH**

**Failure to follow these instructions will result in death, serious injury or property damage.**

**Never attempt to change connections or taps unless the transformer is de-energized and all windings grounded.**

The connecting cable size is determined from the line current rating of the transformers primary and secondary windings and may be selected from the information in appendix A (page 14). Use wire rated for at least 90°C (194°F) and sized on the basis of 75°C (167°F) ampacity. Use with AL9CU-AL-CU lugs. Electrical Connector Lugs, if provided, are to be used with SIW, Class B or Class C cables or wires only.

Conveniently located pre-punched knockouts are provided on all ventilated transformer enclosures up to 150 kVA three phase and 100 kVA single phase, to facilitate cable entry.

For non-ventilated transformers, pre-punched knockouts are not provided and the appropriate cable connector suitable for the application must be used. Please refer to Appendix E (page 17 to 19) for cable entry locations. If a transformer must be relocated to make the necessary cable connections, all safety requirements and the related lifting procedures must be followed.

### Cable Connection Requirements

Side entry of cables is recommended as it leaves the ventilated areas unobstructed.

- For standard ventilated DH type 3R enclosures, bottom entry is permitted only in the areas defined in Appendix E.
- The proper performance of the transformer is dependent on unrestricted airflow entering the bottom ventilation slots and exiting through the top ventilation slots.
- Blocking the bottom ventilation intake with bottom entry conduits/ cables in the area defined between the bottom entry plate, the inside of the transformer legs and the ground floor may result in overheating the transformer.
- For DH type enclosures where bottom entry is permitted in the designated areas, a maximum of 50% of the front bottom area described above may be blocked with conduits/ cables. In extreme cases no more than 70% of this area may be obstructed, but only under the condition that in this case the clearance listed on the nameplate is maintained on all sides of the transformer (both sides, front and back).
- Offset connectors are also available to help with cable connections to terminal pads, to reduce the bending space for the cables

Cable connection lugs of plated copper or aluminum may be used to connect to the transformer terminals. Terminals should be cleaned and electrical joint compounds are recommended for use on all electrical connections.

Refer to the transformer nameplate for primary and secondary voltage connection combinations and primary and/or secondary tap positions as applicable.

Transformers received from the factory will have tap leads installed on the nominal, or 100%, voltage position. The taps


may still be coated with impregnation material and insulation. To change taps, it is necessary to gently remove all contaminants and insulation from the surface of the top and bottom of the taps (eye-loop or lugs) by sanding the lugs to the bare metal.

The surface of the tap lead should be clean and coated subsequently with electrical compound on all non-plated contacts between the jumper terminal and the tap. Assemble jumpers to taps as per Appendix D (Drawing 1 for single conductor eye-loops and tap lugs or Drawing 2 for double conductor eye-loop taps).

The following table may be used as a guideline for minimum clearances at altitudes not exceeding 1000 m (3300 ft.). Above 1000 m (3300 ft.) please consult factory.

Transformer Voltage Class	Minimum Clearance (mm)	Minimum Clearance (in.)
1.2 KV	25	1
2.5 KV	51	2
5.0 KV	102	4
8.7 KV	135	5.3
15 KV	203	8
18 KV	254	10
25 KV	305	12
34.5 KV	406	16

Note: "Some specific component parts of a transformer may require clearances different than those indicated above. For those exceptions, you should comply with the instructions provided in the assembly drawings or installation procedure."




**DANGER**

**HAZARD OF ELECTRIC SHOCK, EXPLOSION OR ARC FLASH**

After installation of cables and connectors, the minimum clearance prescribed by the applicable codes and standards for the respective voltage class must be maintained from energized parts to all case parts. Failure to install cables and connectors as per all applicable codes and standards and the attached guidelines will result in serious personal injury or death and property damage.

**Grounding**



**DANGER**

**HAZARD OF ELECTRIC SHOCK, EXPLOSION OR ARC FLASH**


Failure to properly ground the transformer as per all applicable codes and standards will result in serious personal injury or death.

All core and coil assemblies are solidly grounded to the enclosure internally to ensure that all conductive metal parts have the same potential.

To ensure the safety in operation, the transformer must be properly grounded before energizing. Most transformers have a main ground location identified accordingly. If a main ground location is not provided, it is the responsibility of the installing contractor to make and verify the necessary ground connections.

This grounding should be in accordance with all national and local electrical codes and standards.

**Altering the Transformer**



**DANGER**

**HAZARD OF ELECTRIC SHOCK, EXPLOSION OR ARC FLASH**

Misapplication or misuse of this equipment may result in serious personal injury or death and property damage.

The application of this equipment is the responsibility of the customer or the customer's agent. Misapplication or misuse may result in serious personal injury or death and/or property damage.

Any modifications to this equipment need to meet the applicable codes and standards and the individual performing any modifications is responsible for meeting the performance and safety requirements defined in these regulations. The manufacturer is not liable for modifications performed on this equipment.

## Before Energization



**DANGER**

### HAZARD OF ELECTRIC SHOCK, EXPLOSION OR ARC FLASH

Failure to install the transformer in accordance with all applicable codes/ standards and the instructions in this booklet will result in serious personal injury or death and property damage.

## For the safe and proper operation of the transformer, please check and verify the following:

- a) Ensure correct phase connections. Refer to the nameplate vector diagram.
- b) The load on a delta secondary winding with a 120 volt center tap should not exceed the normal current rating of the winding. This center tap is designed for a max. of 5% of the nameplate kVA.
- c) When windings are connected in parallel (as in the case of dual voltage primaries), the primary taps for all coils must be connected to the identical percentage tap positions to avoid the shorting of turns, or voltage imbalances. For tap positions, refer to the nameplate on the transformer.
- d) The enclosure should be grounded with the appropriately sized conductor as per local codes and standards requirements.
- e) The total load among all the phases should be balanced as much as possible for optimum performance of the transformers windings. The kVA loading on each phase must not exceed 1/3 of the nameplate kVA rating of the transformer.
- f) The appropriate clearance and tightness of all electrical connections should be checked.
- g) Following the proper safety precautions, after energizing and before connecting any loads, please measure and verify the output voltage matches nameplate specifications.
- h) If there is any reason to suspect that the transformer has been exposed to moisture during transit or storage, it should be checked for dryness before energization. This can be done by performing an insulation resistance test (Megger Test). If any exposure to moisture is suspected, the transformer must be dried out before energization by following the dry-out procedures on page 12.

## Operation



**DANGER**

### HAZARD OF ELECTRIC SHOCK, EXPLOSION OR ARC FLASH

Failure to properly operate the transformer as per all applicable codes and standards and the attached instructions will result in serious personal injury or death.

Under full load operating conditions, dry-type transformers may appear warm to the touch, particularly on the cover of the unit.

Standards permit the temperatures of the cover to reach 65°C (149°F) over ambient.

Dry-type transformers are designed to operate continuously at their full nameplate kVA rating under normal operating conditions.

ANSI C57.96 provides guidelines for loading transformers under different operating conditions including:

- ➔ Ambient temperatures that differ from the ambient temperatures required for transformer operation. ANSI recommends a maximum ambient of 40°C.

**WARNING**

Failure to identify and correct the root causes for the transformer overheating can result in death or personal injury, property damage or severely reduced transformer life expectancy.

- ➔ Short time overload as it relates to time and temperature and the corresponding loss of life of the transformer.
- ➔ Overload that results in a reduction of life expectancy of the transformer.

If the transformer is experiencing increased operating temperatures, the following contributing factors should be considered and immediately corrected:

- ➔ Rigorous motor starting loads or other impact type loading. For this type of applications a specific transformer type is required.
- ➔ Over-excitation of unit due to excess supply line voltage or current.
- ➔ Ambient temperatures above standard.
- ➔ Overload beyond ANSI C57.96 guidelines.
- ➔ Harmonic distortions of the supply line voltage and currents.

If overheating is noted, any attempt to add supplemental fan cooling must be in accordance with factory installation guidelines. Incorrectly installed fans can misdirect the airflow and cause serious deterioration of the insulation life expectancy in a transformer coil.

Dry-type transformers may be shut down and stored for extended periods of time without any deterioration. Care must be exercised to clean and dry units prior to energization, as previously outlined. Proper packaging and moisture prevention measures during storing are essential.

**Maintenance****DANGER****HAZARD OF ELECTRIC SHOCK, EXPLOSION OR ARC FLASH**

Failure to de-energize, isolate and ground the transformer terminals and to verify the ground potential on all terminals before performing any work on the transformer will result in serious personal injury or death.

Inserting any objects through the ventilation openings while the transformer is energized will result in serious personal injury or death.

Under normal operating conditions and environments, dry-type transformers require periodic care and inspection. This is essential if the unit is installed in harsh environmental conditions (for ex. outside, environments with high levels of pollutants and dust, etc.).

Peripheral inspection and external dust removal may be performed while the transformer is in operation. However, access covers must not be opened or any objects inserted through the transformer ventilation openings under energized conditions.

**Internal maintenance must be performed only with the transformer de-energized, isolated and with all the terminals grounded.**

Maintenance typically includes internal cleaning, tightening of links and bolted connections to prescribed torque levels, servicing and inspection of auxiliary devices and an infrared scan or thermal image of the transformer.

Air ducts should be maintained free of any accumulation of dust and debris and all bolted connections at terminals must be in good condition. We recommend under scheduled annual maintenance or at shorter regular intervals that connections be

1/4-20	7 [10]	3.8 [5]	5 [6]
3/8-16	20 [27]	14 [18]	15 [20]
1/2-13	60 [70]	33 [45]	37 [50]
8 mm	20 [23]	12 [14]	12 [14]
12 mm	60 [70]	33 [45]	37 [50]

checked for proper torque values and any signs or oxidation, arching and improper electrical connection. If any improper connections are identified they must be corrected immediately.

Vacuuming or blowing of compressed air from the top down is an accepted practice for removing dust from the ducts of a transformer coil. Low pressure, dry air should be used to avoid further contamination of the windings by foreign objects.

The ground connection should also be checked to ensure a low impedance connection. The accumulation of ice, snow or any other objects blocking the ventilation should be cleaned up immediately during the operation of the transformer to ensure proper ventilation.

On outdoor units where filters have been installed, their continuous exposure to the outside atmosphere can cause the filters to get dirty quickly. A periodic check of the filters will help avoid filter clogging and thus transformer overheating. Also, never run the transformer without the filters properly installed.

**\*Note: The above torque values are for dry, unlubricated bolts.**

## Dry-Out of Transformers



**DANGER**

### HAZARD OF ELECTRIC SHOCK, EXPLOSION OR ARC FLASH

Failure to follow the attached dry-out procedures before energizing transformers previously exposed to moisture will result in serious personal injury or death and property damage.

In the event that transformers have been exposed to moisture such as condensation or rain, it is required to dry-out the transformer prior to energization.

Drying may be accomplished by using any hot or warmed air, radiant heat or internal heat that is directed through the windings. Heated air should be allowed to rise up through the windings for a minimum of twenty four (24) hours after the evidence of moisture is no longer visible.

Transformers that have been exposed to flood conditions, direct rain or sprinklers, may not be able to be dried out appropriately. The insulation resistance, core to primary, core to secondary and primary to secondary, should be greater than 10k ohms. Contact the transformer manufacturer for appropriate action instructions.

## Accessories



**DANGER**

### HAZARD OF ELECTRIC SHOCK, EXPLOSION OR ARC FLASH

When installing transformers (regardless of the location) the installing contractor is responsible for the proper installation in accordance with the attached instructions and all applicable codes and standards (including Seismic). Failure to do so will result in serious personal injury or death and property damage.

Dry-type distribution transformers are available with a number of accessories to facilitate installation. Consult your local distributor for the purchase of any of the items accessories that are stocked in inventory. Some frequently used accessories include:

#### 1) Wall Mounting Brackets

Ventilated dry-type transformers are normally designed to be floor mounted only. However, depending on the enclosure type some ventilated units up to 112.5 kVA are supplied in enclosures that have integral wall mounting capabilities or may be wall-mounted using kits. These units can be conveniently mounted on walls, beams or poles. For seismic ratings (where applicable) please refer to the unit's nameplate.

Conventional ventilated dry-type transformers have a bottom screen for air convection. When transformers are mounted above the ground surface a catcher plate (drip plate) should be installed under each transformer as a safety precaution against any hot particles that may fall through the screen in the event of a faulted

condition. Refer to Appendix B and C (page 15 and 16).

## **2) Sound Isolation Pads and Vibration Isolation Kits**

For maximum absorption of vibration and reductions of sound levels, additional sound isolation pads are recommended for installation between the transformer and the mounting surface.

These molded neoprene and steel plate assemblies virtually eliminate vibration noise between the transformer and the mounting surface.

Consult the HPS standard products catalog, general information section, for the part number of the correct isolation pad required.

## **3) Connectors (Lugs)**

Connectors for the installation of dry-type transformers are readily available. These connectors are suitable for use with either copper or aluminum cables.

Connectors should be sized, installed and connected to cables in accordance with your local electrical code requirements using the best practices to ensure safe and reliable operation. Cable surfaces should be properly cleaned and electrical compound should be used for all connections.

### **Selecting Connectors**

- a) Determine the primary current for the required transformer from the Appendix A.
- b) Similarly, determine the secondary current rating for the transformer from Appendix A.
- c) For 120/240 voltage connections the current should be based on 120 volts.
- d) For 240/480 volt connections, the current should be based on 240 volts.

**APPENDIX A****AMPACITY RATINGS FOR CONNECTIONS**

- A. For a single phase transformer

$$\text{Line Amperes} = \frac{\text{Volt Amperes}}{\text{Line Volts}}$$

- B. For a three phase transformer

$$\text{Line Amperes} = \frac{\text{Volt Amperes}}{1.732 \times \text{Line Volts}}$$

**Full Load Current Table  
Single Phase Transformer**

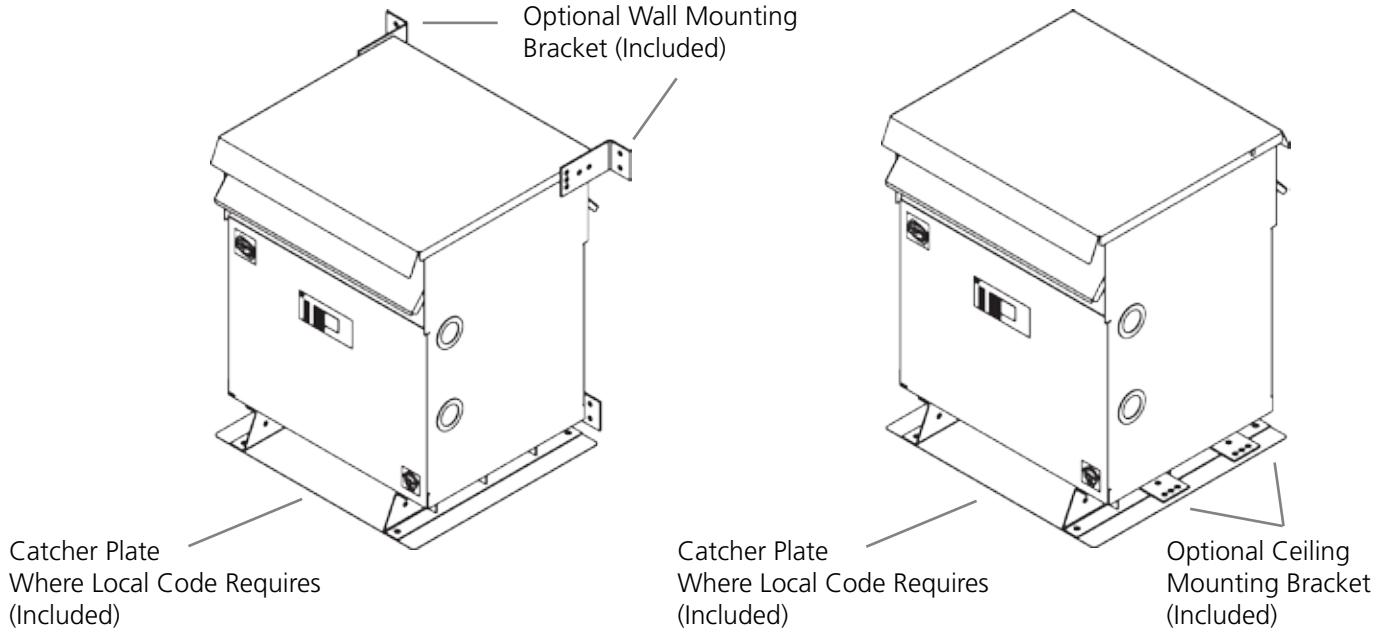
kVA	Current in Amperes					
	120V	240V	480V	600V	2400V	4160V
0.50	4.17	2.08	1.04	0.83	-	-
0.75	6.25	3.13	1.56	1.25	-	-
1.0	8.33	4.17	2.08	1.67	-	-
1.5	12.5	6.25	3.13	2.50	-	-
3.0	25.0	12.5	6.25	5.00	1.25	0.72
5.0	41.7	20.8	10.4	8.33	2.08	1.20
7.5	62.5	31.3	15.6	12.5	3.13	1.80
10	83.3	41.7	20.8	16.7	4.17	2.40
15	125	62.5	31.3	25.0	6.25	3.61
25	208	104	52.1	41.7	10.4	6.01
37.5	313	156	78.1	62.5	15.6	9.01
50	417	208	104	83.3	20.8	12.0
75	625	313	156	125	31.3	18.0
100	833	417	208	167	41.7	24.0
150	1250	625	313	250	62.5	36.0
167	1392	696	348	278	69.6	40.1
250	2083	1042	521	417	104	60.1
333	2775	1388	694	555	139	80.0

**Full Load Current Table  
Three Phase Transformer**

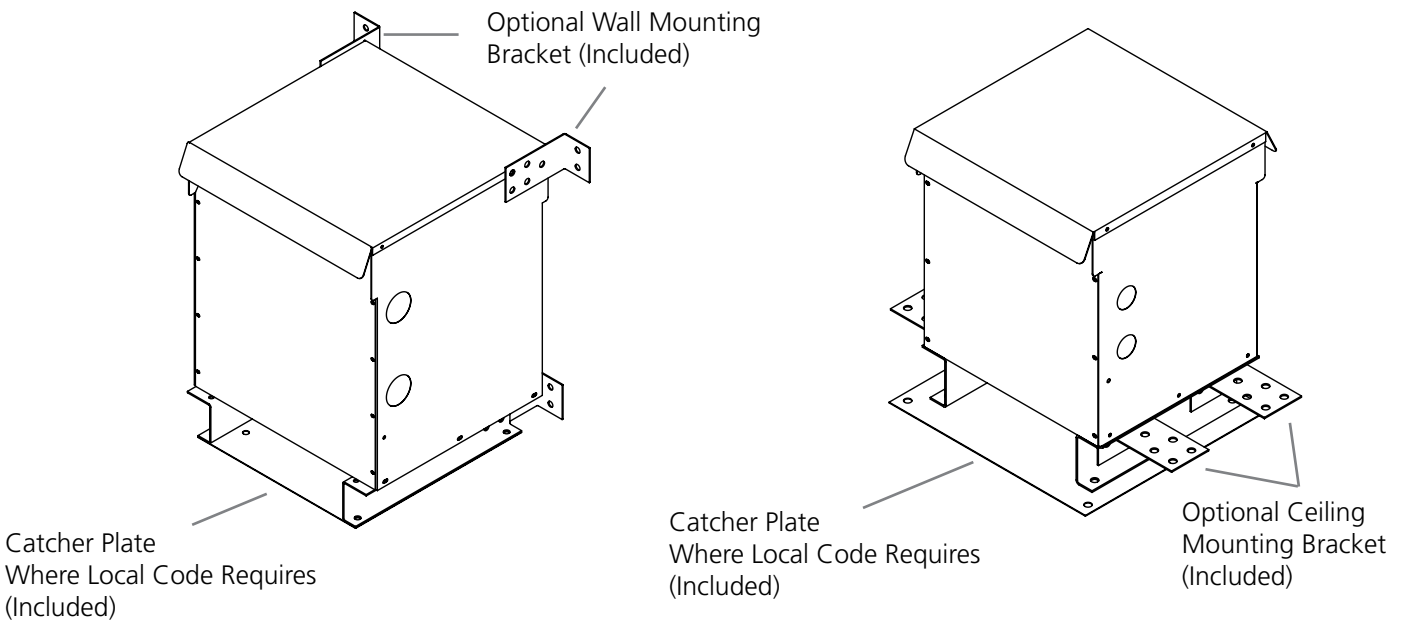
kVA	Current in Amperes					
	208V	240V	480V	600V	2400V	4160V
3	8.33	7.22	3.61	2.89	0.72	0.42
6	16.7	14.4	7.22	5.77	1.44	0.83
9	25.0	21.7	10.8	8.66	2.17	1.25
15	41.6	36.1	18.0	14.4	3.61	2.08
30	83.3	72.2	36.1	28.9	7.22	4.16
45	125	108	54.1	43.3	10.8	6.25
75	208	180	90.2	72.2	18.0	10.4
100	278	241	120	96.2	24.1	13.9
112.5	312	271	135	108	27.1	15.6
150	416	361	180	144	36.1	20.8
225	625	541	271	217	54.1	31.2
300	833	722	361	289	72.2	41.6
450	1249	1082	541	433	108	62.4
500	1388	1203	601	481	120	69.4
600	1665	1443	722	577	144	83.3
750	2082	1804	902	722	180	104
1000	2776	2406	1203	962	241	139
1500	4164	3609	1804	1443	361	208
2000	5552	4811	2406	1925	481	278
2500	6940	6014	3007	2406	601	347
3000	8327	7217	3608	2887	722	416

**APPENDIX B**

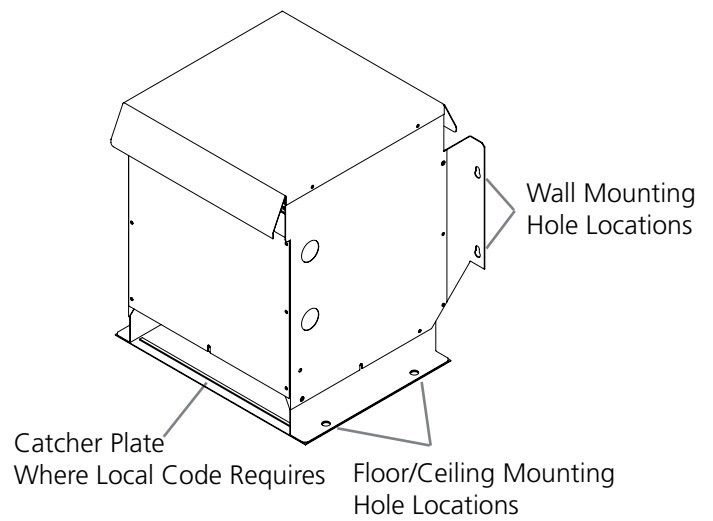
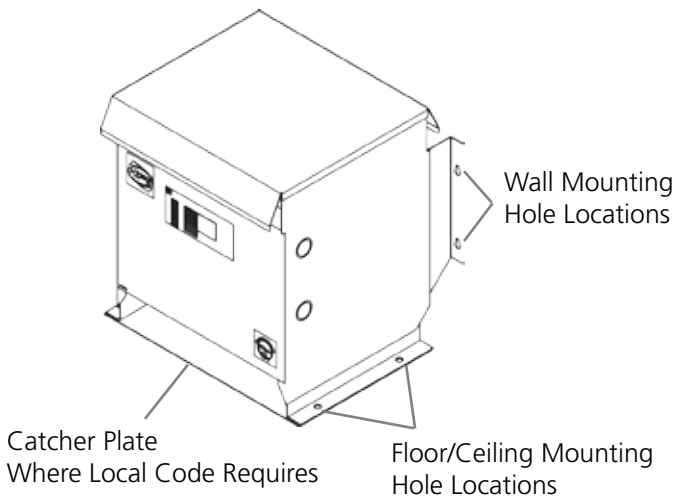
LOCATION OF WALL MOUNTING BRACKETS AND CATCHER PLATES INCLUDED IN THE DW3 ACCESSORY KIT  
FOR DH3 SERIES TYPE 3R ENCLOSURES



LOCATION OF WALL MOUNTING BRACKETS AND CATCHER PLATES INCLUDED IN THE NW2 ACCESSORY KIT  
FOR NH3 SERIES TYPE 3R ENCLOSURES

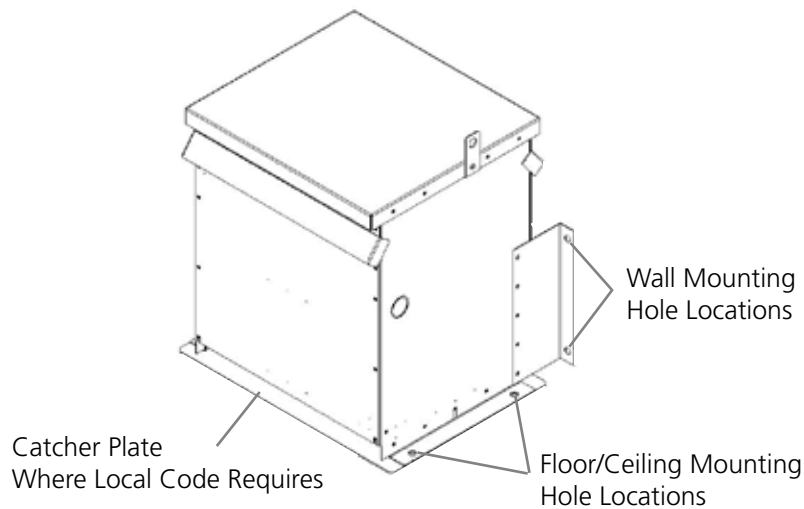


**APPENDIX C**



LOCATION OF WALL MOUNTING BRACKETS AND CATCHER PLATES INCLUDED IN THE DH1DP AND DH2DP FOR DH1 & DH2 SERIES TYPE 3R ENCLOSURES

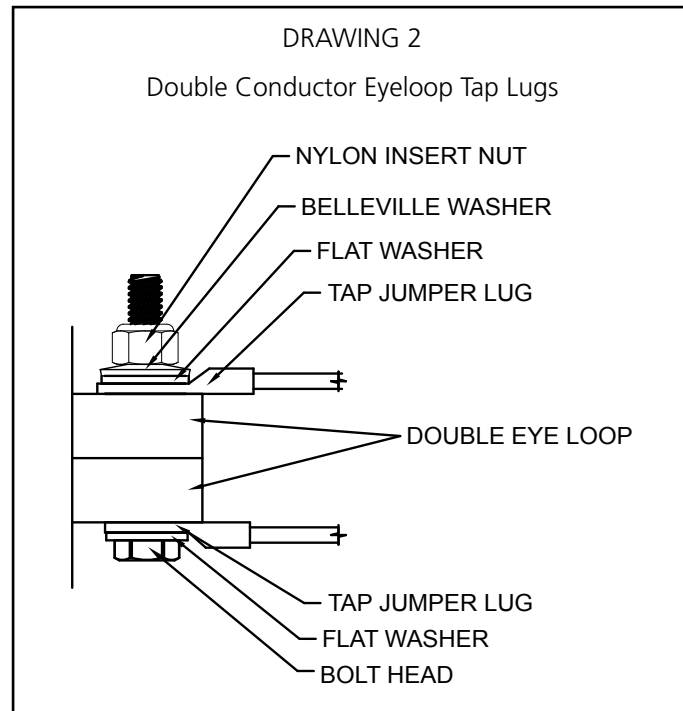
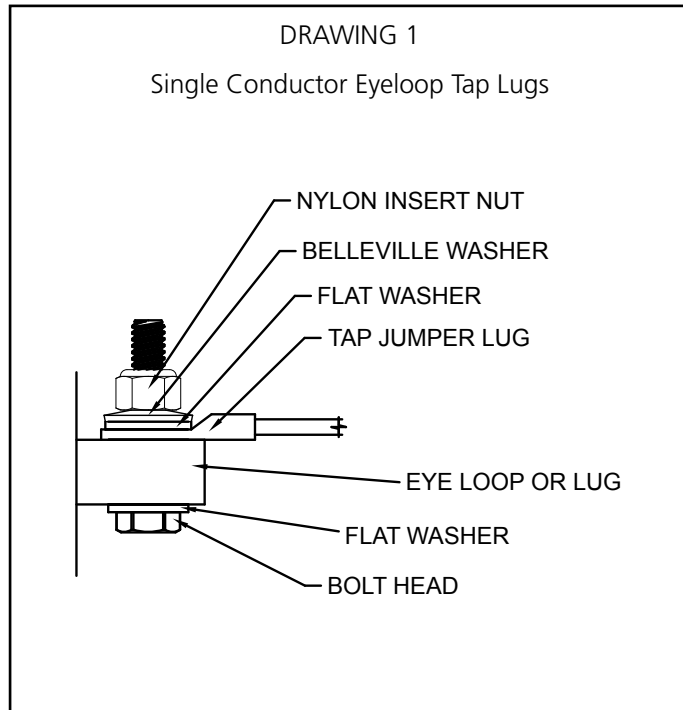
LOCATION OF WALL MOUNTING BRACKETS AND CATCHER PLATES INCLUDED IN THE NH5DP AND NH6DP FOR NH5 & NH6 SERIES TYPE 3R ENCLOSURES



LOCATION OF OPTIONAL WALL MOUNTING BRACKETS AND CATCHER PLATES INCLUDED IN THE CN1DP, CN2DP, AND CN3DP FOR CN1, CN2 & CN3 SERIES TYPE 3R ENCLOSURES

**APPENDIX D**

Jumper Assembly Drawings



## APPENDIX E

### Suggested Cable Entry Locations

**FIGURE 1**

#### Typical Type 3R, DH1 to DH4 Ventilated Enclosure Assembly for Three Phase and Single Phase Transformers.

Notes:

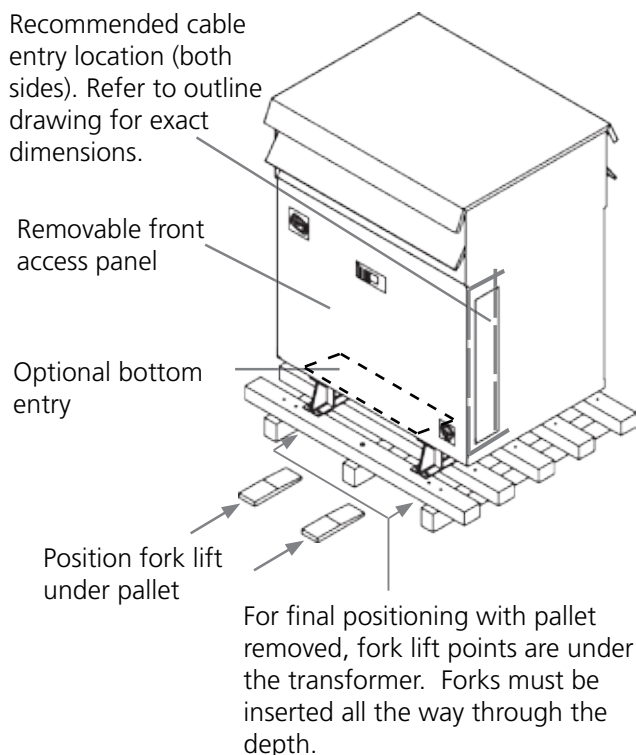
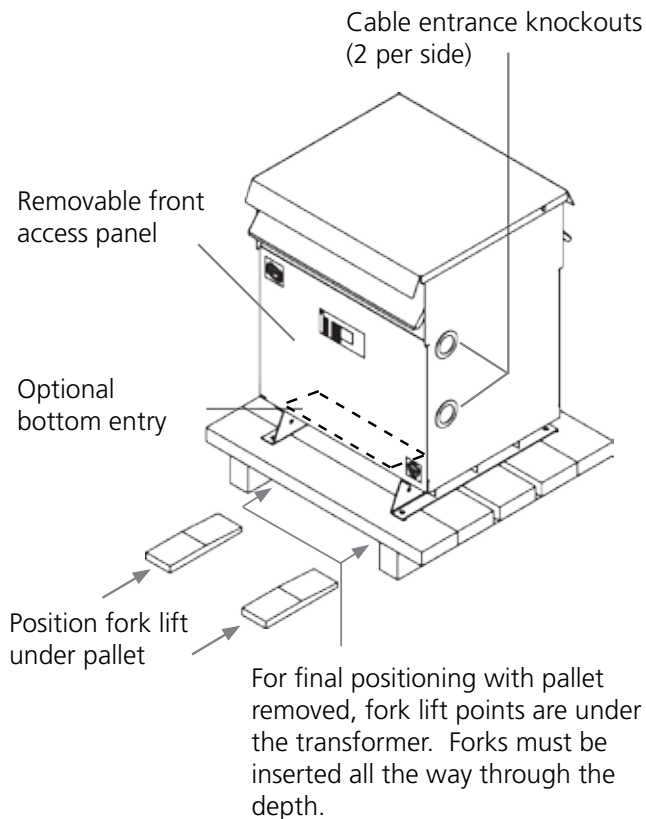
1. Handling - units are designed to be raised by a fork lift from underneath the pallet. Final positioning of the unit with the pallet removed can be via a fork lift under the transformer with the forks between the channels.
2. Shipping - units are shipped on pallets which are to be removed at installation.
3. Installation - This transformer can be installed indoor or outdoor providing a degree of protection against falling rain, sleet and external ice formation.
4. All general purpose/drive isolation transformers should be located away from any wall or any other obstruction, please refer to the nameplate for the minimum distance.
5. DO NOT block bottom ventilation area

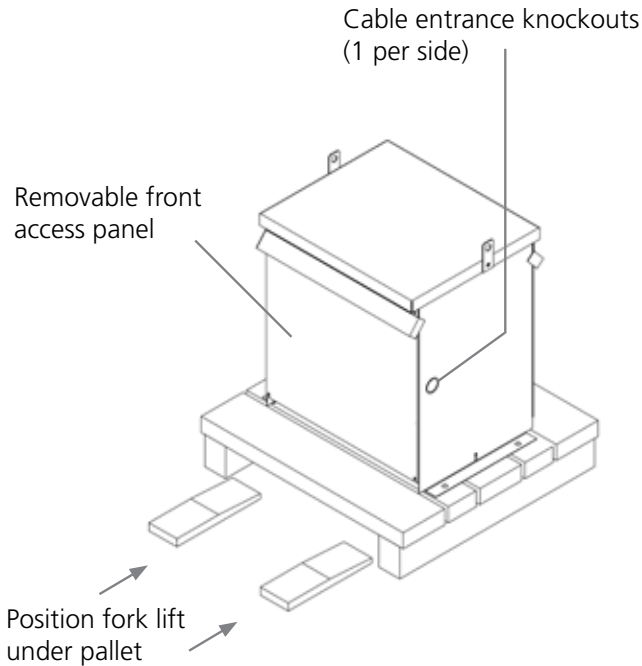
**FIGURE 2**

#### Typical Type 3R, DH5 to DH10 Series Ventilated Enclosure Assembly for Three Phase or Single Phase Transformers.

Notes:

1. Handling - units are designed to be raised by a fork lift from underneath the pallet. Final positioning of the unit with the pallet removed can be via a fork lift under the transformer with the forks between the channels. **(Note: Transformers weighing greater than 2350 lbs should be lifted by removing the top panel and accessing the lifting provisions on top of the top of the core and coil.)**
2. Shipping - units are shipped on pallets which are to be removed at installation.
3. Installation - This transformer can be installed indoor or outdoor providing a degree of protection against falling rain, sleet and external ice formation.
4. All general purpose/drive isolation transformers should be located away from any wall or any other obstruction, please refer to the nameplate for the minimum distance. (Note: These enclosures are not intended to be wall mounted. They may be mounted on a customer supplied platform.)
5. DO NOT block bottom ventilation area.

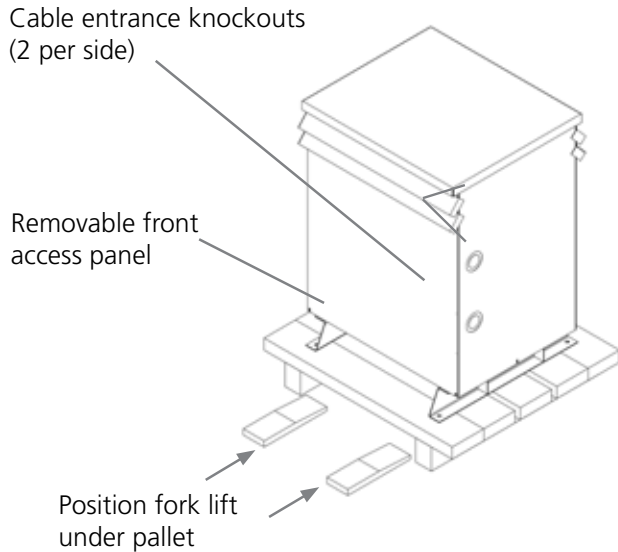


**FIGURE 3**

**Typical Type 3R, CN1 to CN3 Ventilated Enclosure Assembly for Three Phase and Single Phase Transformers.**

## Notes:

1. Handling - units are designed to be raised by a fork lift from underneath the pallet. Final positioning of the unit with the pallet removed can be via a hoist or forklift mounted lifting attachment.
2. Shipping - units are shipped on pallets which are to be removed at installation.
3. Installation - This transformer can be installed indoor or outdoor providing a degree of protection against falling rain, sleet and external ice formation.
4. All general purpose/drive isolation transformers should be located away from any wall or any other obstruction, please refer to the nameplate for the minimum distance.
5. DO NOT block bottom ventilation area

**FIGURE 4**

**Typical Type 3R, CN4 to CN7 Series Ventilated Enclosure Assembly for Three Phase or Single Phase Transformers.**

## Notes:

1. Handling - units are designed to be raised by a fork lift from underneath the pallet. Final positioning of the unit with the pallet removed can be via a fork lift under the transformer with the forks between the channels. The forks must extend out past the back of the unit and all enclosure panels must be in place.
2. Shipping - units are shipped on pallets which are to be removed at installation.
3. Installation - This transformer can be installed indoor or outdoor providing a degree of protection against falling rain, sleet and external ice formation.
4. All general purpose/drive isolation transformers should be located away from any wall or any other obstruction, please refer to the nameplate for the minimum distance. (Note: These enclosures are not intended to be wall mounted. They may be mounted on a customer supplied platform.)
5. DO NOT block bottom ventilation area.

**FIGURE 5****Typical Type 3R, NH Series Ventilated Enclosure Assembly for Three Phase and Single Phase Transformers.**

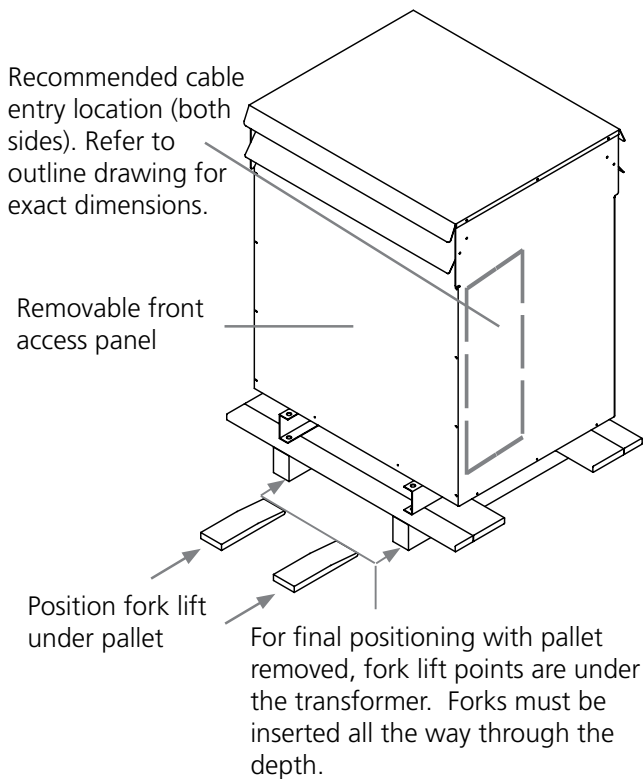
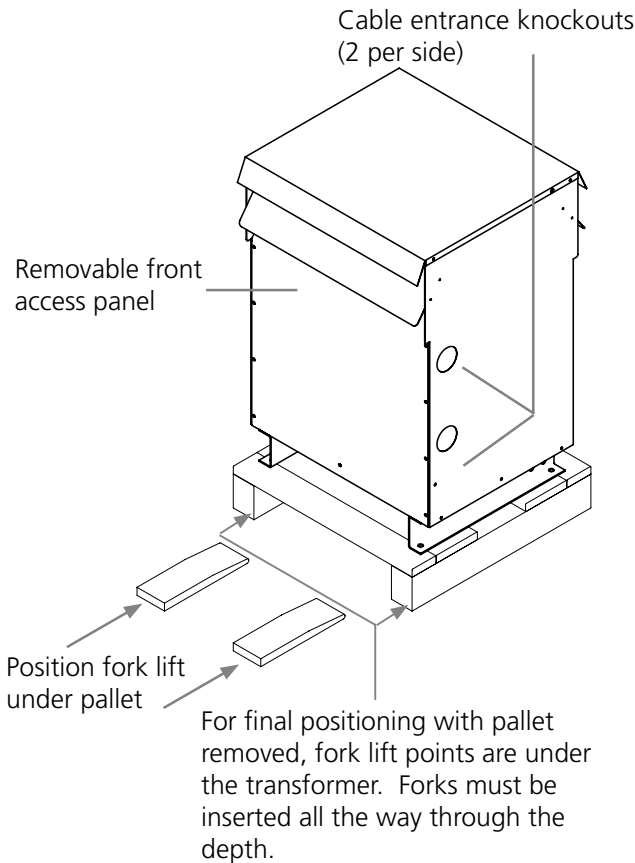
## Notes:

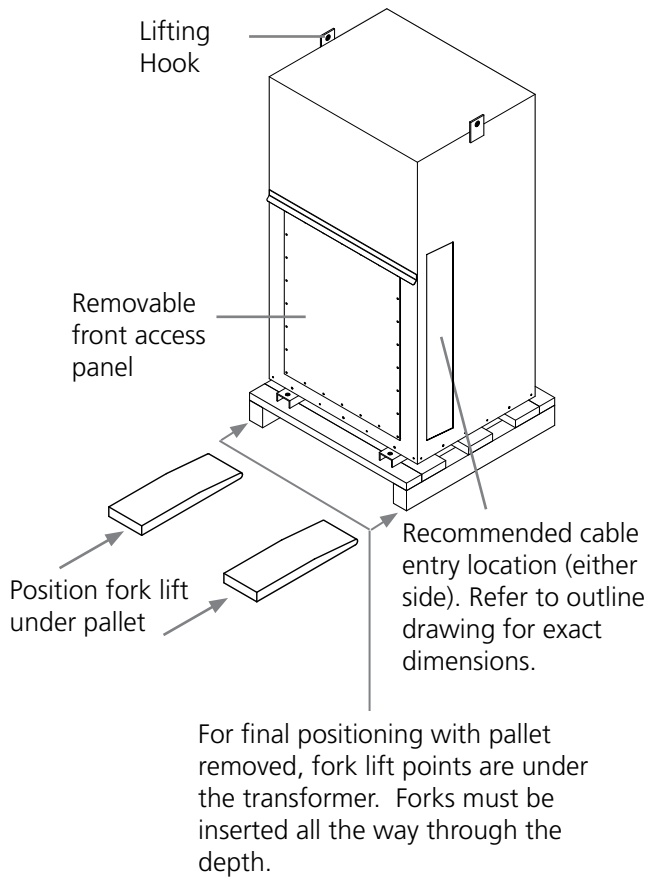
1. Handling - units are designed to be raised by a fork lift from underneath the pallet. Final positioning of the unit with the pallet removed can be via a fork lift under the transformer with the forks between the channels.
2. Shipping - units are shipped on pallets which are to be removed at installation.
3. Installation - This transformer can be installed indoor or outdoor providing a degree of protection against falling rain, sleet and external ice formation.
4. All general purpose/drive isolation transformers should be located away from any wall or any other obstruction, please refer to the nameplate for the minimum distance.
5. DO NOT block bottom ventilation area

**FIGURE 6****Typical Type 3R, NJ Series Ventilated Enclosure Assembly for Three Phase or Single Phase Transformers.**

## Notes:

1. Handling - units are designed to be raised by a fork lift from underneath the pallet. Final positioning of the unit with the pallet removed can be via a fork lift under the transformer with the forks between the channels. **(Note: Transformers weighing greater than 2350 lbs. should be lifted by removing the top panel and accessing the lifting provisions on top of the top of the core and coil.)**
2. Shipping - units are shipped on pallets which are to be removed at installation.
3. Installation - This transformer can be installed indoor or outdoor providing a degree of protection against falling rain, sleet and external ice formation.
4. All general purpose/drive isolation transformers should be located away from any wall or any other obstruction, please refer to the nameplate for the minimum distance. (Note: These enclosures are not intended to be wall mounted. They may be mounted on a customer supplied platform.)
5. DO NOT block bottom ventilation area.



**FIGURE 7**

**Typical Type 4 & 12, NH Series Non-Ventilated Enclosure Assembly for Three Phase or Single Phase Transformers.**

Notes:

1. Handling - units are designed to be raised by a fork lift from underneath the pallet. Final positioning of the unit with the pallet removed can be via a fork lift under the transformer with the forks between the channels or with the lifting hooks if provided.
2. Shipping - units are shipped on pallets which are to be removed at installation.
3. Installation - This is a non-ventilated indoor or outdoor enclosure designed primarily to provide a degree of protection against falling dirt, rain, sleet, snow, windblown dust, splashing water, hose-directed water and that will be undamaged by the external formation of ice on the enclosure. It is suitable in areas where exposure to large amounts water from any direction is possible. (Note: not submersible)
4. All general purpose/drive isolation transformers should be located away from any wall or any other obstruction, please refer to the nameplate for the minimum distance.