

Raychem AMC-1B

LINE-SENSING THERMOSTAT FOR NONHAZARDOUS LOCATIONS INSTALLATION INSTRUCTIONS

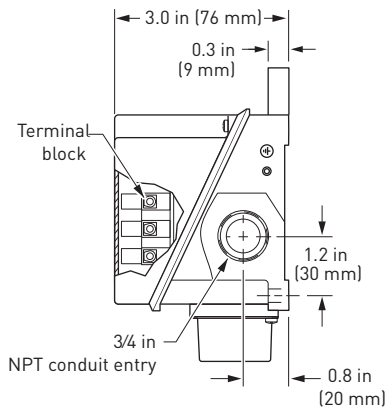
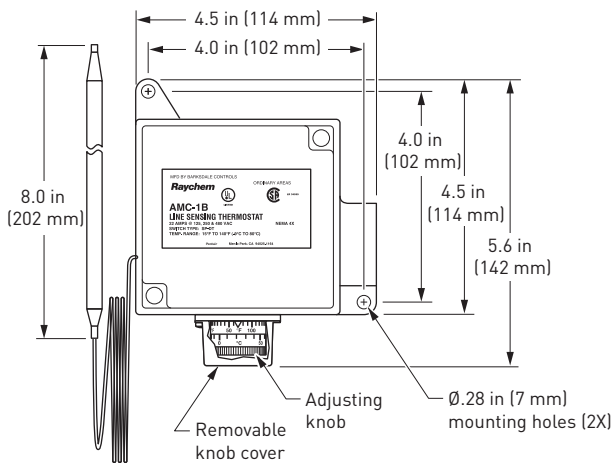
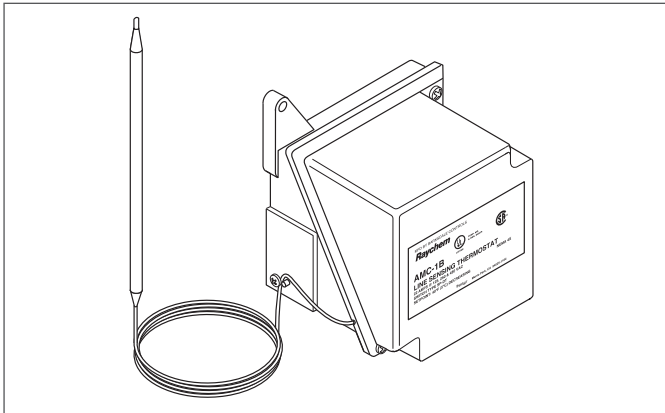

DESCRIPTION

The AMC-1B thermostat is designed for controlling heat-tracing systems in nonhazardous locations. The AMC-1B can be used to control heat-tracing circuits in a pipe-sensing mode (see Figure 1 on back), to indicate low-temperature (Figure 2) or high temperature (Figure 3) alarm conditions, or to control the coil on a contactor (Figure 4).

APPROVALS



SPECIFICATIONS

Enclosure	NEMA 4X, polyurethane-coated cast-aluminum housing, stainless-steel hardware
Entries	One 3/4 in. NPT conduit hub
Set point range	25°F to 325°F (-4°C to 163°C)
Sensor exposure limits	-40°F to 420°F (-40°C to 215°C)
Housing exposure limits	-40°F to 160°F (-40°C to 71°C)
Switch	SPDT
Electrical rating	22 A at 125/250/480 Vac
Accuracy	±6°F (±3.3°C)
Deadband	2°F to 12°F (1.1°C to 6.7°C) above actuation temperature
Set point repeatability	±3°F (±1.7°C)
Sensor type	Fluid-filled (silicone) bulb and 9 ft (2.7 m) capillary
Sensor material	300 series stainless steel
Connection terminals	Screw terminals, 10-14 AWG (2-5 mm ²)

WARNING:

This component is an electrical device. It must be installed correctly to ensure proper operation and to prevent shock or fire. Read these important warnings and carefully follow all the installation instructions.

Component approvals and performance are based on the use of specified parts only. Do not use substitute parts or vinyl electrical tape to make connections.

THERMOSTAT INSTALLATION INSTRUCTIONS

1. Verify that the thermostat is suitable for the area where it is to be installed.
2. Check the line voltage and the heat-tracing load to ensure that the thermostat ratings are not exceeded.
3. Mount the unit using unistrut or the Raychem Universal Mounting Bracket (UMB-263757) in a position that prevents condensation from draining into the enclosure from the connecting conduit (see diagram above).

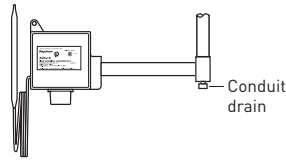

5. Tape the bulb firmly to the pipe with AT-180 aluminum tape, making sure there is no air space between the bulb and pipe. Do not overlap the bulb and heating cable with the same piece of AT-180 tape.
6. For metal-tank-wall sensing, use the BCK-35 bulb clamp (purchased separately) and install the clamp per the instructions provided. Make sure there is no air space between the tank wall and the bulb.
For installation on plastic tanks, contact Pentair Industrial Heat Tracing Solutions at (800) 545-6258.

POSITIONING THE SENSOR BULB

4. Position the bulb in the lower quadrant of the pipe as shown in the diagrams to the left. Place the bulb at least three feet from pipe supports, valves, or other heat sinks; protect the capillary from kinks or bends less than 1/2 inch in radius.

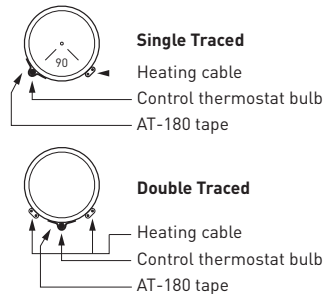

SETTING THE THERMOSTAT

7. Set the thermostat dial to the desired temperature, then finish wiring.
8. Complete insulating. Do not turn the system on until the bulb is covered with thermal insulation.
9. Fill the piping or tank. Once the thermostat has begun to cycle, check the fluid temperature with an immersed thermostat (best for plastic systems) or an accurate temperature indicator. Adjust the dial setting, if necessary.

WIRING

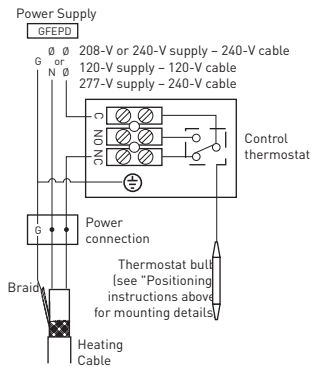

Figure 1. Pipe-sensing

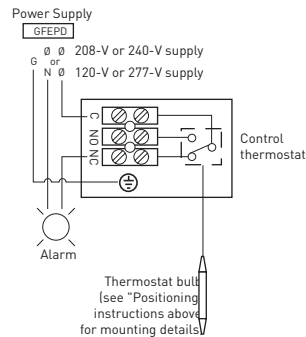

Figure 2. Low-temperature alarm

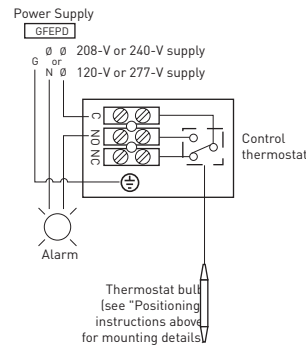

Figure 3. High-temperature alarm

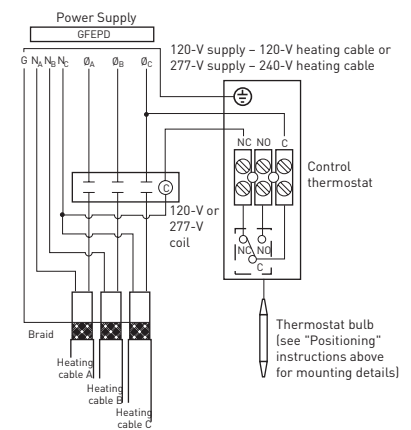

Figure 4. Contactor control

For switching heat-tracing loads greater than 22 A or switching multiple heat-tracing circuits.



WWW.PENTAIRTHERMAL.COM

NORTH AMERICA

Tel: +1.800.545.6258
Fax: +1.800.527.5703
Tel: +1.650.216.1526
Fax: +1.650.474.7711
thermal.info@pentair.com

EUROPE, MIDDLE EAST, AFRICA

Tel: +32.16.213.511
Fax: +32.16.213.603
thermal.info@pentair.com

ASIA PACIFIC

Tel: +86.21.2412.1688
Fax: +86.21.5426.2937
cn.thermal.info@pentair.com

LATIN AMERICA

Tel: +1.713.868.4800
Fax: +1.713.868.2333
thermal.info@pentair.com

Pentair is owned by Pentair or its global affiliates. All other trademarks are the property of their respective owners. Pentair reserves the right to change specifications without prior notice.

© 2001-2015 Pentair.

PN 342449