

Raychem C75-100-A

HEATING CABLE GLAND KIT INSTALLATION INSTRUCTIONS

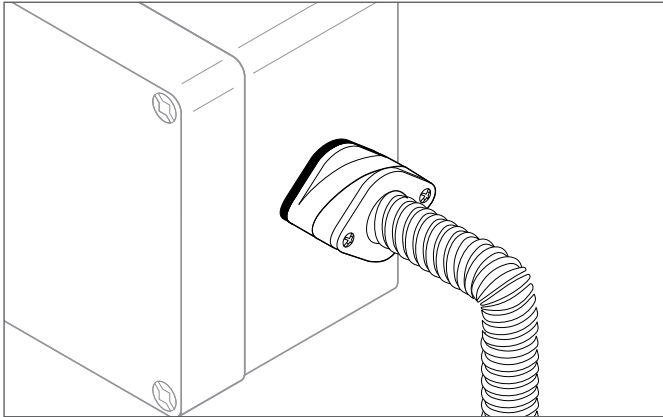

APPROVALS

Hazardous Locations



Class I, Div. 2, Groups A, B, C, D
Class II, Div. 2, Groups F, G
Class III



- WS



- WS

Ex e II T⁽¹⁾⁽²⁾
(1) T-Rating, same as heating cable
(2) Certified for use only when used with a CSA certified Zone 1 enclosure & DIN rail mounted terminal block



GM-XT heating cable system
Class I, Div. 2, Groups A, B, C, D

Nonhazardous Locations for GM-X and GM-XT Heating Cable Systems



De-icing and snow melting equipment



- WS



DESCRIPTION

The C75-100-A is a NEMA 4X-rated gland kit used to transition heating cables into a junction box when making connections off of a pipe, tank or roof. It may be used for power, splice, or tee connections. The C75-100-A is for use with Raychem BTV-CR, BTV-CT, QTVR-CT, XTV-CT, KTV-CT(1), LBTV2-CT(2), VPL-CT industrial parallel heating cables and GM-X and GM-XT roof and gutter de-icing heating cables. The kit does not include the junction box, flexible tubing, or tape, which are required to make a complete connection.

For technical support call Pentair Industrial Heat Tracing Solutions at (800) 545-6258.

TOOLS REQUIRED

- Utility knife
- Wire cutters
- Marker
- 3/16 in (4 mm) or smaller slotted screwdriver
- No. 2 Phillips or 1/4 in (6 mm) slotted screwdriver
- For LBTV2-CT only: Heat gun or mini-torch
- Needle nose pliers
- Adjustable pliers
- Wire stripper (for VPL)

ADDITIONAL MATERIALS REQUIRED

- Agency approved NEMA 4X-rated junction box with 3/4-in NPT threaded entry or through hole.
- Tape:
 - GT-66 Installation temperature above 40°F [5°C]
 - GS-54 Installation temperature above -40°F [-40°C]
- One length of flexible tubing, 6 ft (1 3/4 m) maximum, Raychem HCTE-1000-0 P/N 3679754004
- (1) For KTV-CT only: Order PMK-GP-10 grommet P/N 700823
- (2) For LBTV2-CT only: HCS-100-A heat shrink core sealer P/N 257649-000 and PMK-GK-10 grommet P/N 222724-000
- For CSA Zone 1 Hazardous Locations: Zone 1 certified enclosure & DIN rail mounted terminal block.

KIT CONTENTS

Item	Qty	Description
A	1	Red grommet
B	1	Gland with threaded inserts
C	1	Gland with screws
D	1	Gland gasket
E	1	Locknut
F	1	Green/yellow tube
G	1	CS-100 core sealer
H	1	Terminal block

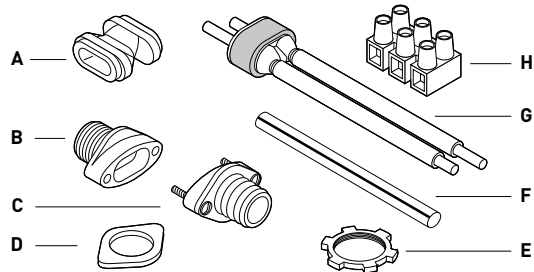

WARNING:

This component is an electrical device that must be installed correctly to ensure proper operation and to prevent shock or fire. Read these important warnings and carefully follow all of the installation instructions.

- To minimize the danger of fire from sustained electrical arcing if the heating cable is damaged or improperly installed, and to comply with the requirements of Pentair, agency certifications, and the national electrical codes, ground-fault equipment protection must be used. Arcing may not be stopped by conventional circuit breakers.

- Component approvals and performance are based on the use of Pentair-specified parts only. Do not use substitute parts or vinyl electrical tape.
- The black heating cable core is conductive and can short. They must be properly insulated and kept dry.
- Damaged bus wires can overheat or short. Do not break bus wire strands when scoring the jacket or core.
- Keep components and heating cable ends dry before and during installation.
- Use only fire-resistant insulation materials, such as fiberglass wrap or flame-retardant foam.

CAUTION:

HEALTH HAZARD: Prolonged or repeated contact with the sealant in the core sealer may cause skin irritation. Wash hands thoroughly. Overheating or burning the sealant will produce fumes that may cause polymer fume fever. Avoid contamination of cigarettes or tobacco. Consult MSDS VEN0058 for further information.

CHEMTREC 24-hour emergency telephone:
(800) 424-9300

Non-emergency health and safety information:
(800) 545-6258.

Heating cable types

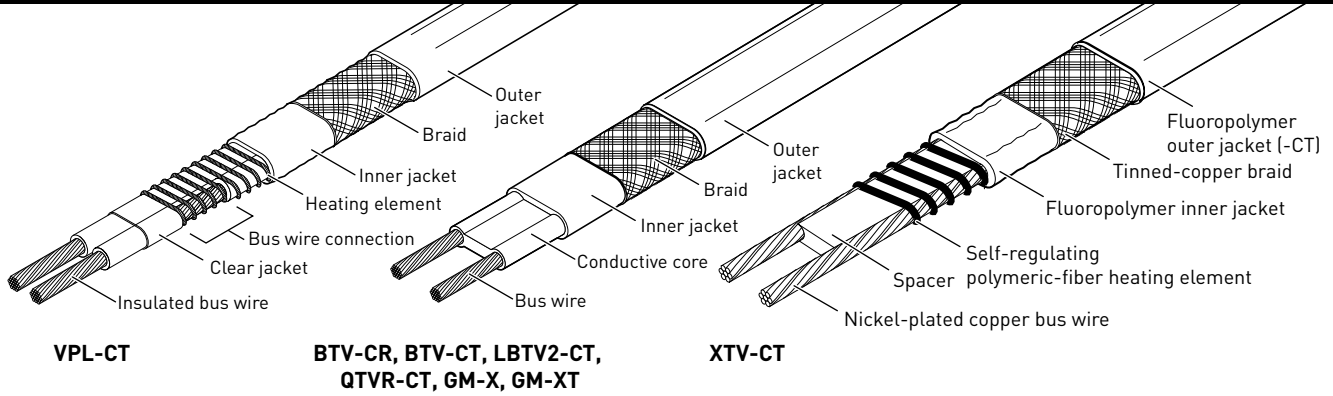

1

- Select correct grommet from the chart below.

Heating Cable	Grommet
GM-X, GM-XT, BTV-CR, BTV-CT, QTVR-CT, VPL-CT, XTV-CT	Red
LBTV2-CT	K*
KTV-CT	P

* Order separately

WARNING: Use of the wrong grommet can result in leaks, cracked components, shock or fire, and will invalidate approvals and certifications.

- For LBTV2-CT a separate heat-shrinkable core sealer is required. Order one HCS-100 heat shrink core sealer.

2A For threaded junction boxes

- For VPL heating cables only:
Cut heating cable 12 in (30 cm) from the center of the first indentation.

- Mount box on wall or bracket.
- Install gland with threaded inserts into hub.
- Slide parts onto heating cable.

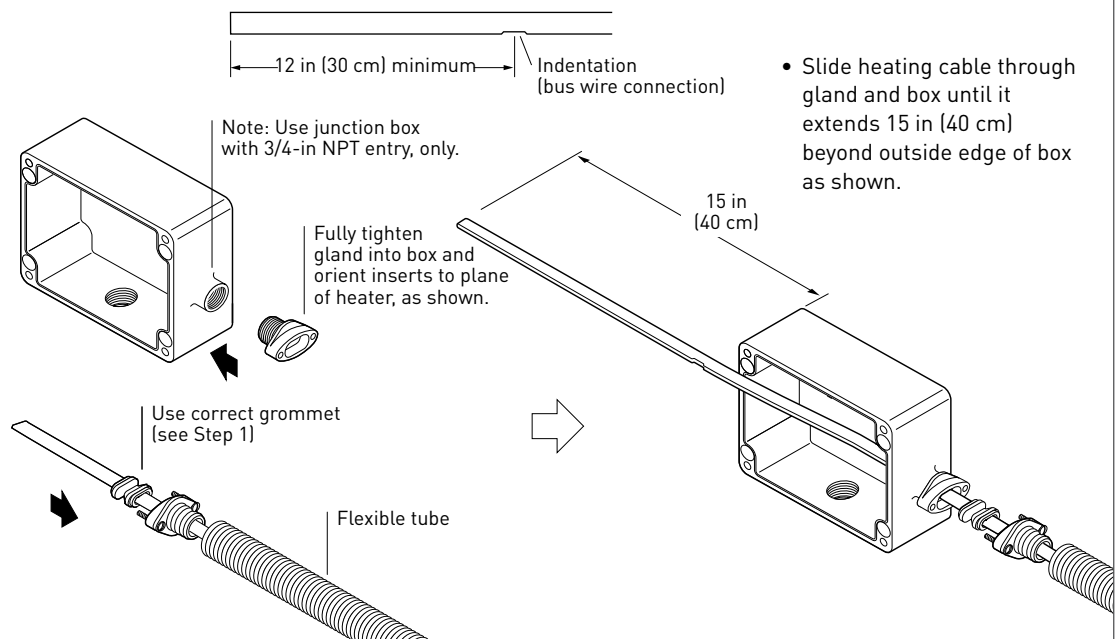

- Slide heating cable through gland and box until it extends 15 in (40 cm) beyond outside edge of box as shown.

2B For through hole junction boxes

- For VPL heating cables only:
Cut heating cable 12 in (30 cm) from the center of the first indentation (bus wire connection).

- Mount box on wall or bracket.
- Install gland with gasket into box wall; secure with locknut.
- Slide parts onto heating cable.

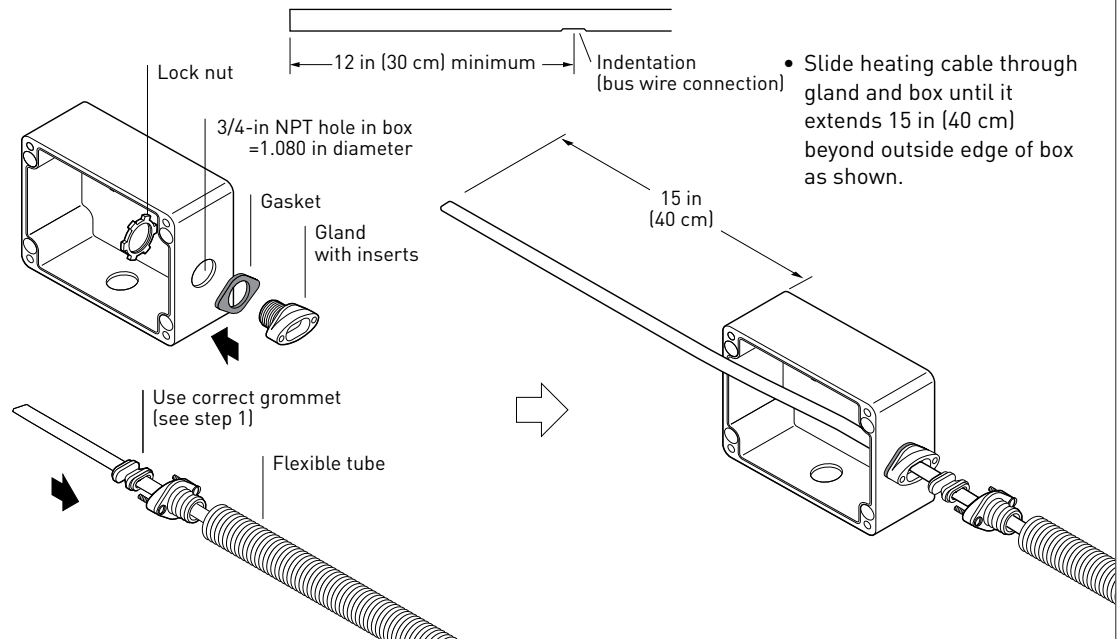

- Slide heating cable through gland and box until it extends 15 in (40 cm) beyond outside edge of box as shown.

2C For GM-X, GM-XT and threaded junction boxes (outdoor location)

Note: If your installation requires that the heating cable be installed in flexible conduit as shown in 14b, add the appropriate amount of heating cable.

WARNING: Prevent mechanical damage. When installed as shown, the junction box is supported by a non-metallic mounting gland. This method may only be used where the box is not exposed to mechanical stress, static loads, or impact. Protect it with a shield or mount it out of the reach of people or moving equipment.

- Thread the cap of the Y fitting with 3/4-in NPT entry.
- Thread the gland fitting without the captive screws into the cap of the Y fitting.
- Slide parts onto heating cable.

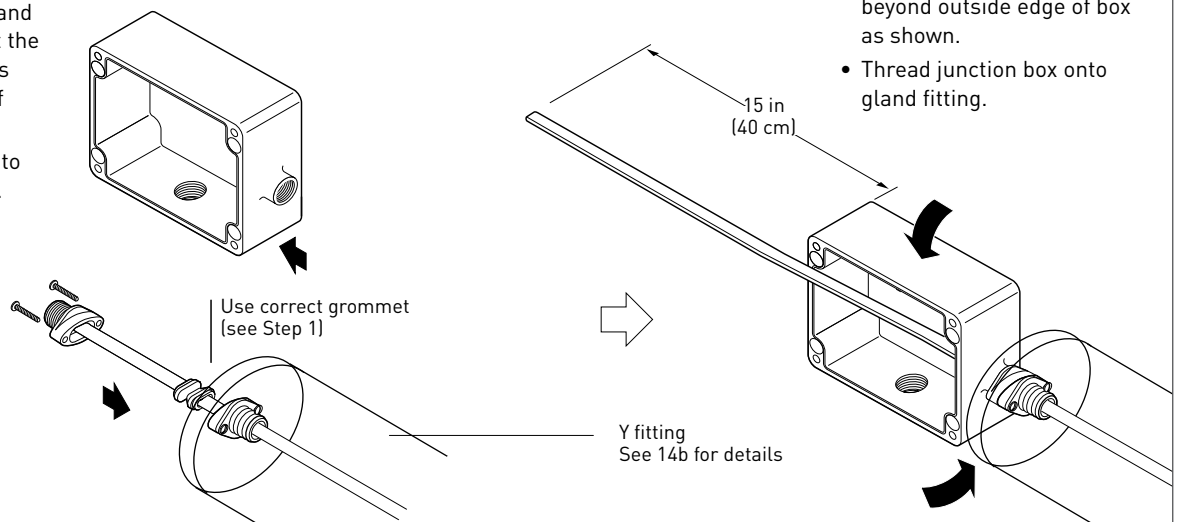

- Slide heating cable through gland and box until it extends 15 in (40 cm) beyond outside edge of box as shown.
- Thread junction box onto gland fitting.

2D For GM-X, GM-XT and through hole junction boxes (indoor dry location)

Note: If your installation requires that the heating cable be installed in flexible conduit as shown in 14C, add the appropriate amount of heating cable.

WARNING: Prevent mechanical damage. When installed as shown, the junction box is supported by a non-metallic mounting gland. This method may only be used where the box is not exposed to mechanical stress, static loads, or impact. Protect it with a shield or mount it out of the reach of people or moving equipment.

- Slide parts onto heating cable in the sequence and orientation shown.
- Bring the Y fitting part together and tighten the two screws.
- Slide the gasket threaded end with captive screw.
- Insert thread end into box entry hole and loosely tighten lock nut.

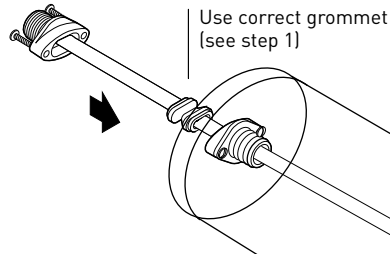
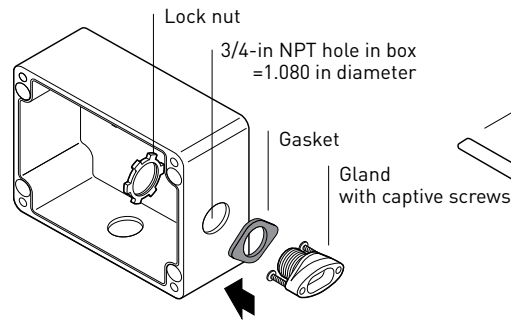

- Slide heating cable through gland and box until it extends 15 in (40 cm) beyond outside edge of box as shown.
- Tighten lock nut to junction box on gland fitting.

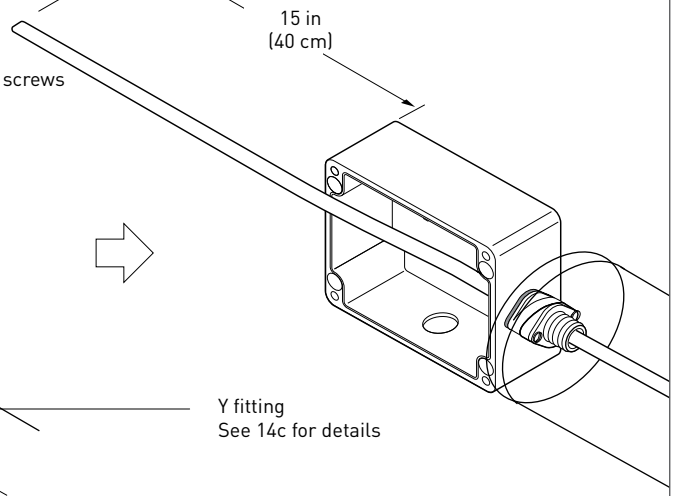

3

- Lightly score outer jacket around and down as shown.
- Bend heating cable to break jacket at score, then peel off jacket.

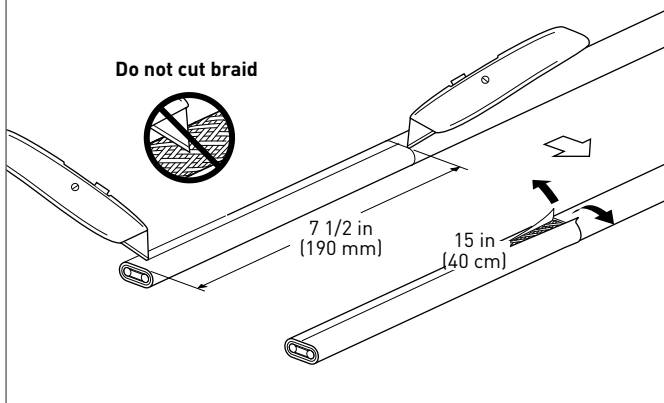

4

VPL

Go to Step 5A

GM-X, GM-XT, BTV, QTVR, LBTV2

Go to Step 5B

XTV

Go to Step 5C

5A

VPL

- Push braid back and bunch as tight as possible.

- Lightly score inner jacket around and down as shown.

- Peel off inner jacket.

- Unwind heating element, cut and remove as shown.

- Lightly score clear jacket around and down as shown.

- Bend heating cable to break jacket at the score then peel off jacket.

- Push braid forward. Use a screwdriver to open braid as shown.

- Bend heating cable and work it through opening in braid.

- Remove insulation from ends of bus wires.

- Pull braid tight to make pigtail.

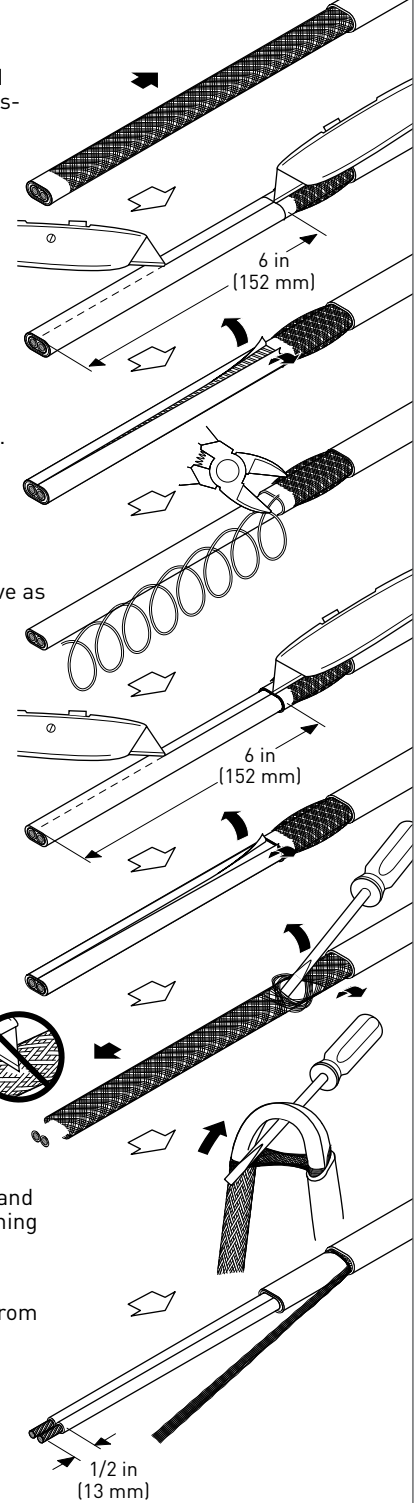

Go to Step 6

5B

GM-X, GM-XT, BTV, QTVR, LBTV2

- Push braid back to create a pucker.

- At pucker use a screwdriver to open braid.
- Bend heating cable and work it through opening in braid.

- Lightly score base jacket around and down as shown.

- Peel off base jacket.
- Notch core.
- Peel bus wire from core.

- Score core between bus wires at inner jacket.

- Bend and snap core.
- Peel core from bus wire.

- Remove any remaining core material from bus wires.
- Pull braid tight to make pigtail.

Go to Step 6

5C

XTV

- Push braid back to create a pucker.

- At pucker use a screwdriver to open braid.
- Bend heating cable and work it through opening in braid.

- Lightly score base jacket around and down as shown.

- Peel off base jacket.

- Notch core.
- Cut and remove all fiber strands.

- Score and remove center spacer.
- Bend and snap core.

- Remove any remaining fiber material from bus wires.
- Pull braid tight to make pigtail.

Go to Step 6

6

- Mark the jacket as shown.

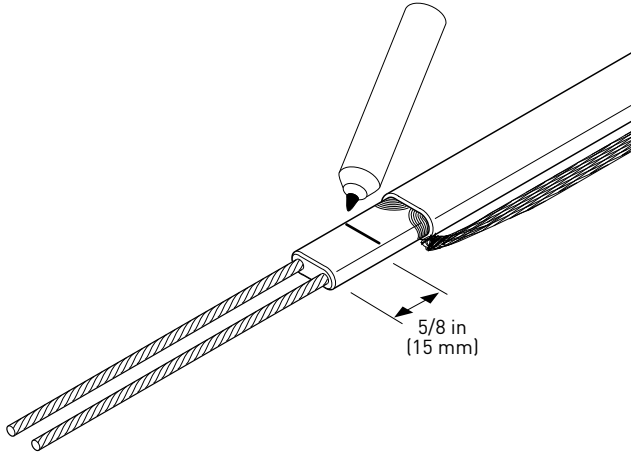

7

⚠ Caution: Health Hazard.
Wash hands after contact with sealant. Consult material safety data sheet VEN0058.

- If needed, re-twist and straighten bus wires, then insert into the guide tubes as shown.

Make sure all strands go into the tubes.

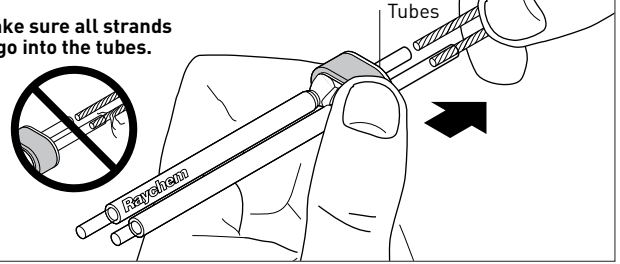

8

- Push core sealer onto the heating cable to the mark made in Step 6.
- Extra force may be required for larger cables or at lower temperatures.

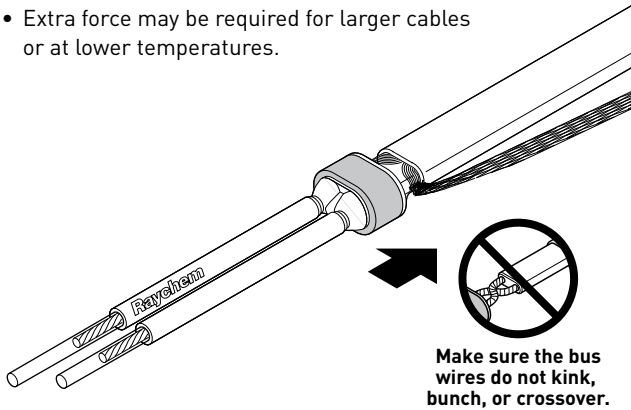

9

- Remove the guide tubes and dispose of them in a plastic bag.

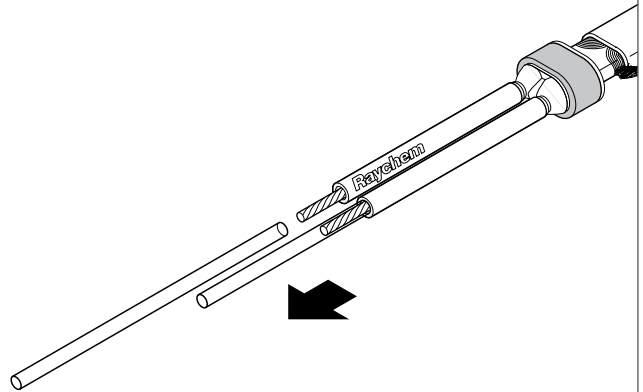

10

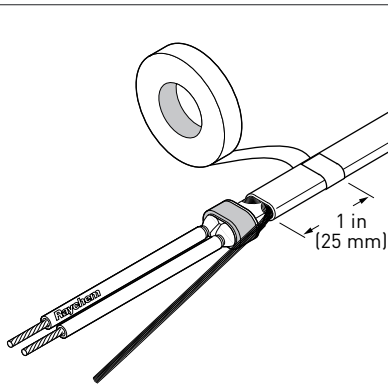

- Apply 3 wraps of glass tape (Raychem GT-66 or GS-54).

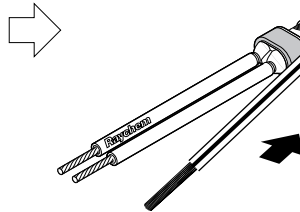

- Slip the green/yellow tube onto the braid. Heat shrinking is not required.

11A For threaded hole junction boxes

- Pull cable back through gland and box until tape is located just inside hub.
- Seat grommet in gland as shown.
- Position gland with screws next to grommet and tighten screws.
- Thread flexible tube onto gland.
- Install conduit and pull in power and ground wires for power connections.

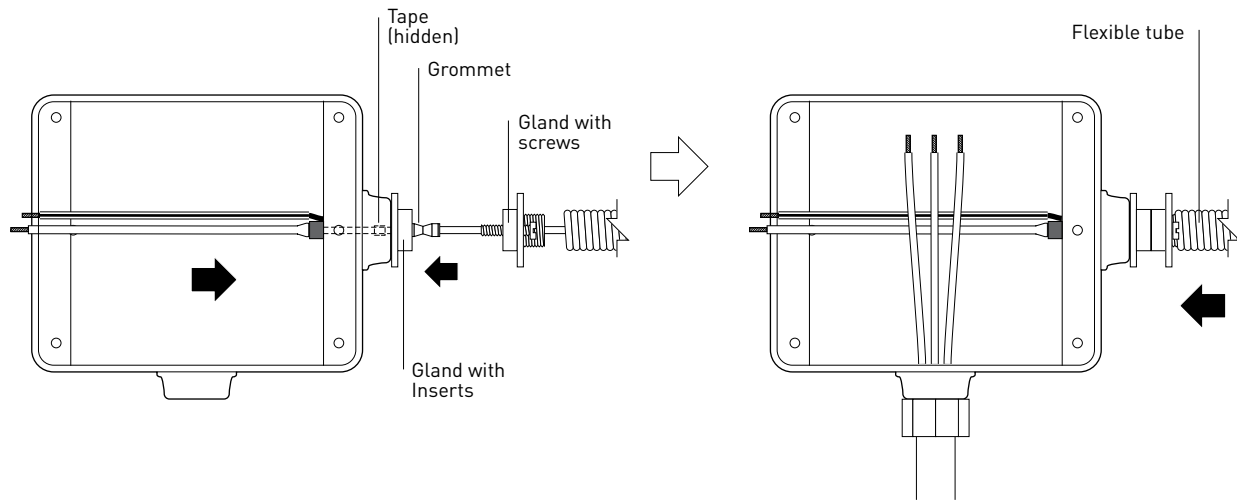

11B For through hole junction boxes

- Pull cable back through gland and box until tape is located just inside gland with inserts.
- Seat grommet in gland as shown.
- Position gland with screws next to grommet and tighten screws.
- Thread flexible tube onto gland.
- Install conduit and pull in power and ground wires for power connections.

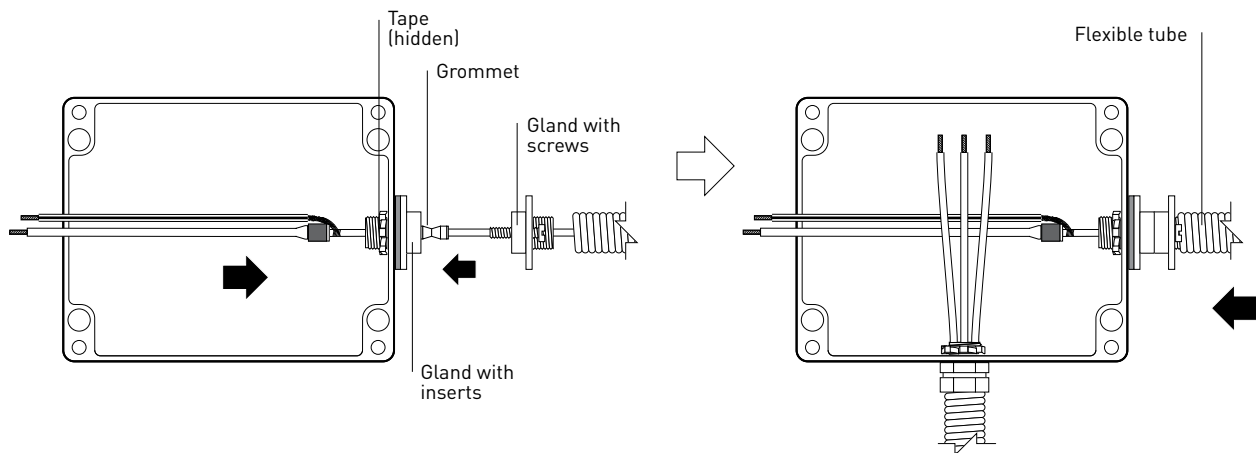

12

Note the following instructions on bus wire preparation:

For tee, install two wires in one terminal:

- Twist appropriate wire pair together.
- Trim twisted wires to 1/2 in (13 mm).

Otherwise, trim single wires to 3/8 in (10 mm).

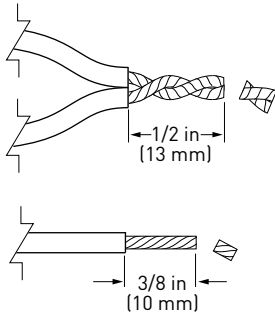

Note: For CSA certified Zone 1 DIN rail mounted terminal blocks, install bus wire in accordance with manufacturer's specifications.

13

- Connect bus wires and braid to terminal block.
- Connect power wires and ground wire to terminal block for power connections. This connection must be protected by a ground-fault equipment protection device.

Note: For CSA Zone 1 hazardous locations, discard terminal block supplied with the C75-100-A kit & use a CSA certified Zone 1 DIN rail mounted terminal block.

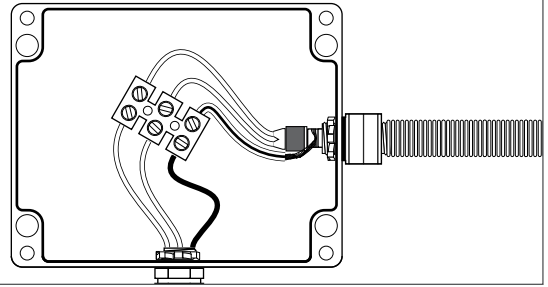

14A

- Stow wires in box and install lid.
- Secure flexible tube with tape (Raychem GT-66 or GS-54).

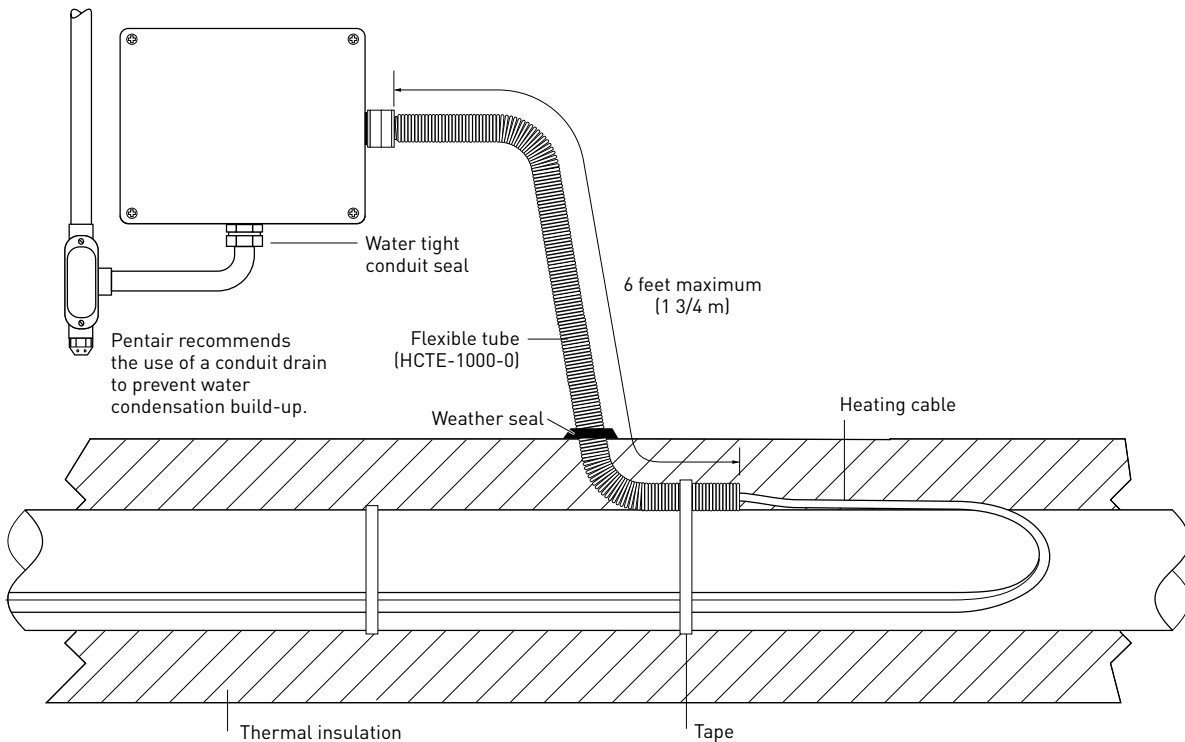

14B For GM-X, GM-XT and threaded junction boxes (outdoor location)

- Install the junction box either directly to the gland fitting in the cap of the Y fitting or to the end of the flexible conduit as shown below.
- Stow wires in box and install lid.

⚠ WARNING: Prevent mechanical damage. When installed as shown, the junction box is supported by a non-metallic mounting gland. This method may only be used where the box is not exposed to mechanical stress, static loads, or impact. Protect it with a shield or mount it out of the reach of people or moving equipment.

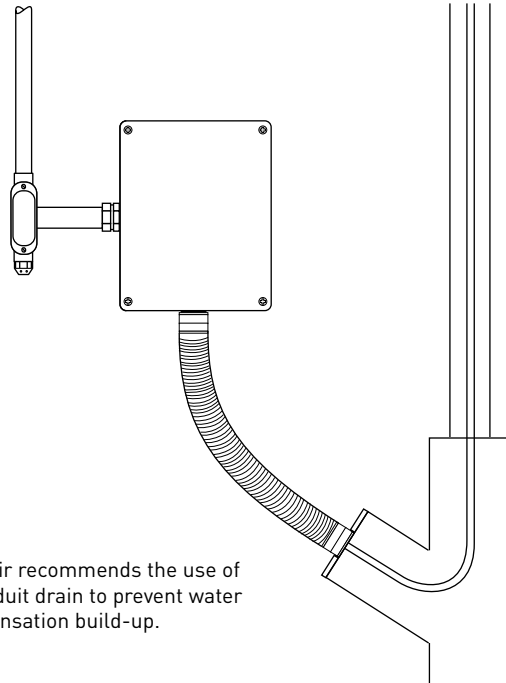
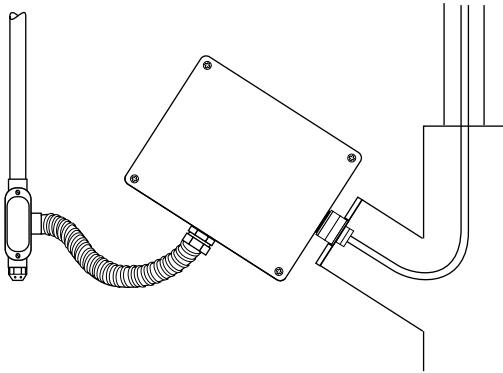

14C For GM-X, GM-XT and through hole junction boxes (indoor dry location)

- Install the junction box either directly to the gland fitting in the cap of the Y fitting or to the end of the flexible conduit as shown below.
- Stow wires in box and install lid.

⚠ WARNING: Prevent mechanical damage. When installed as shown, the junction box is supported by a non-metallic mounting gland. This method may only be used where the box is not exposed to mechanical stress, static loads, or impact. Protect it with a shield or mount it out of the reach of people or moving equipment.

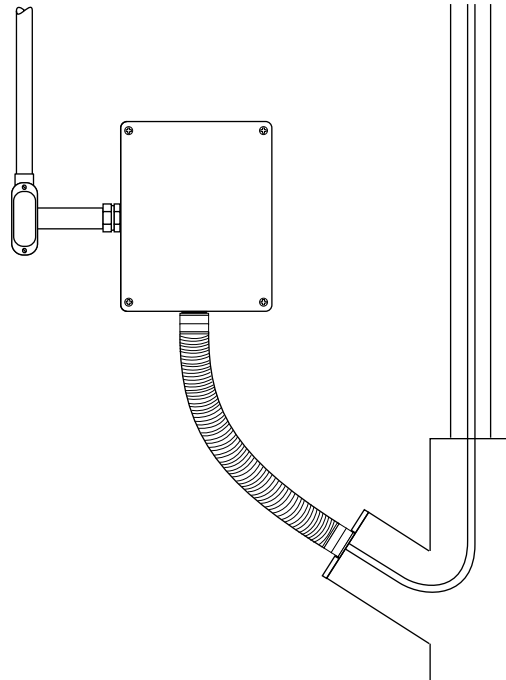
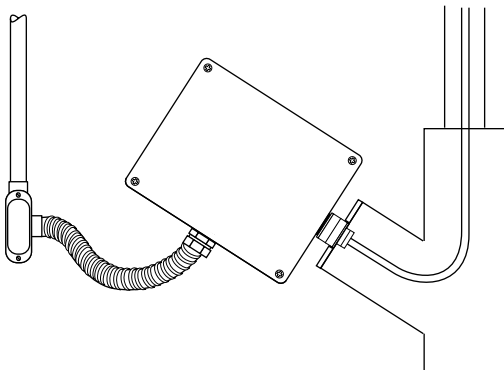

14D For installation in instrument enclosures

- Install the power junction box either directly to the instrument enclosure or to the end of the flexible conduit.
- Install C75-100-A and associated heat-tracing cable inside the instrument enclosure and close the lid.

