

BMXAMM0600

analog non isolated high level IO module,
Modicon X80, 4 I, 2 O, 0 to 20mA, 4 to 20mA,
10V positive or negative



Main

Range of Product	Modicon X80
Product or Component Type	Mixed analog I/O module
Electrical connection	20 ways 1 connector
Isolation between channels	Non isolated
Input level	High level
Analogue input number	4
Analogue input type	Current 0...20 mA Current 4...20 mA Voltage +/- 10 V Voltage 0...10 V Voltage 0...5 V Voltage 1...5 V

Complementary

Analogue input resolution	12 bits 0...20 mA 12 bits 0...5 V 12 bits 1...5 V 12 bits 4...20 mA 13 bits 0...10 V 14 bits +/- 10 V
Permitted overload on inputs	+/- 30 mA 0...20 mA +/- 30 mA 4...20 mA +/- 30 V +/- 10 V +/- 30 V 0...10 V +/- 30 V 0...5 V +/- 30 V 1...5 V
Input impedance	250 Ohm
Precision of internal conversion resistor	0.1 % - 15 ppm/°C
Type of filter	First order digital filtering by firmware
Fast read cycle time	1 ms + 1 ms x number of channels used
Nominal read cycle time	5 ms for 4 channels
Measurement error	0.25 % of full scale 0...20 mA 25 °C output 0.25 % of full scale 4...20 mA 25 °C output <= 0.35 % of full scale +/- 10 V 0...60 °C input <= 0.35 % of full scale 0...10 V 0...60 °C input <= 0.35 % of full scale 0...5 V 0...60 °C input <= 0.35 % of full scale 1...5 V 0...60 °C input <= 0.5 % of full scale 0...20 mA 0...60 °C input <= 0.5 % of full scale 4...20 mA 0...60 °C input <= 0.6 % of full scale +/- 10 V 0...60 °C output <= 0.6 % of full scale 0...20 mA 0...60 °C output <= 0.6 % of full scale 4...20 mA 0...60 °C output 0.25 % of full scale +/- 10 V 25 °C output 0.25 % of full scale +/- 10 V 25 °C input 0.25 % of full scale 0...10 V 25 °C input 0.25 % of full scale 0...5 V 25 °C input 0.25 % of full scale 1...5 V 25 °C input 0.35 % of full scale 0...20 mA 25 °C input 0.35 % of full scale 4...20 mA 25 °C

The information provided in this documentation contains general descriptions and/or technical characteristics of the performance of the products contained herein. This documentation is not intended as a substitute for and is not to be used for determining suitability or reliability of these products for specific user applications. It is the duty of any such user or integrator to perform the appropriate and complete risk analysis, evaluation and testing of the products with respect to the relevant specific application or use thereof. Neither Schneider Electric Industries SAS nor any of its affiliates or subsidiaries shall be responsible or liable for misuse of the information contained herein.

Temperature drift	100 ppm/°C +/- 10 V output 100 ppm/°C 0...20 mA output 100 ppm/°C 4...20 mA output 30 ppm/°C +/- 10 V input 30 ppm/°C 0...10 V input 30 ppm/°C 0...5 V input 30 ppm/°C 1...5 V input 50 ppm/°C 0...20 mA input 50 ppm/°C 4...20 mA input
Recalibration	Factory calibrated on outputs Internal on inputs
Minimum crosstalk attenuation	70 dB
Common mode rejection	80 dB
Isolation voltage	1400 V DC between channels and ground 1400 V DC between channels and bus 750 V DC between group of I/O channels
Output level	High level
Analogue output number	2
Analogue output type	Current 0...20 mA Current 4...20 mA Voltage +/- 10 V
Analogue output resolution	11 bits, 0...20 mA 11 bits, 4...20 mA 12 bits, +/- 10 V
Conversion time	<= 2 ms
Maximum conversion value	+/- 11.25 V +/- 10 V output +/- 11.25 V +/- 10 V input 0...30 mA 0...20 mA input 0...30 mA 4...20 mA input +/- 11.25 V 0...10 V input +/- 11.25 V 0...5 V input +/- 11.25 V 1...5 V input 0...24 mA 0...20 mA output 0...24 mA 4...20 mA output
Fallback mode	Predefined Configurable
MTBF reliability	1400000 H
Operating altitude	0...6561.68 ft (0...2000 m) 2000...5000 m with derating factor
Status LED	1 LED (Green) RUN 1 LED per channel (Green) channel diagnostic 1 LED (Red) ERR 1 LED (Red) I/O
Net Weight	0.34 lb(US) (0.155 kg)
Power consumption in W	2.6 W 24 V DC typical 3.2 W 24 V DC maximum 0.35 W 3.3 V DC typical 0.48 W 3.3 V DC maximum
Current consumption	240 mA 3.3 V DC

Environment

Vibration resistance	3 gn
Shock resistance	30 gn
Ambient Air Temperature for Storage	-40...185 °F (-40...85 °C)
Ambient Air Temperature for Operation	32...140 °F (0...60 °C)
Relative humidity	5...95 % 131 °F (55 °C) without condensation
IP Degree of Protection	IP20
Directives	2014/35/EU - low voltage directive 2014/30/EU - electromagnetic compatibility
Product Certifications	CE[RETURN]RCM[RETURN]CSA[RETURN]EAC[RETURN]Merchant Navy[RETURN]JUL
Standards	EN/IEC 61010-2-201 EN/IEC 61131-2 UL 61010-2-201 CSA C22.2 No 61010-2-201

Ordering and shipping details

Category	18160-MODICON M340
Discount Schedule	PC34
GTIN	3595863966268
Returnability	Yes
Country of origin	FR

Packing Units

Unit Type of Package 1	PCE
Number of Units in Package 1	1
Package 1 Height	2.17 in (5.500 cm)
Package 1 Width	4.33 in (11.000 cm)
Package 1 Length	4.57 in (11.600 cm)
Package 1 Weight	6.03 oz (171.000 g)
Unit Type of Package 2	S02
Number of Units in Package 2	15
Package 2 Height	5.91 in (15.000 cm)
Package 2 Width	11.81 in (30.000 cm)
Package 2 Length	15.75 in (40.000 cm)
Package 2 Weight	6.35 lb(US) (2.882 kg)

Offer Sustainability

California proposition 65	WARNING: This product can expose you to chemicals including: Lead and lead compounds, which is known to the State of California to cause cancer and birth defects or other reproductive harm. For more information go to www.P65Warnings.ca.gov
REACH Regulation	 REACH Declaration
EU RoHS Directive	Pro-active compliance (Product out of EU RoHS legal scope)
Mercury free	Yes
China RoHS Regulation	 China RoHS Declaration
RoHS exemption information	 Yes
WEEE	The product must be disposed on European Union markets following specific waste collection and never end up in rubbish bins.

Contractual warranty

Warranty	18 months
----------	-----------

Modules Mounted on Racks

Dimensions

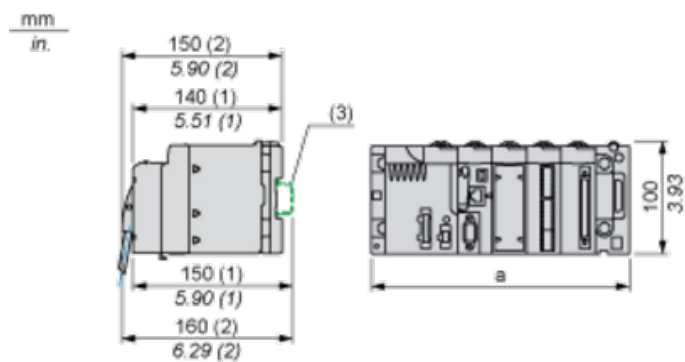

(1) With removable terminal block (cage, screw or spring).

(2) With FCN connector.

(3) On AM1 ED rail: 35 mm wide, 15 mm deep. Only possible with BMXXBP0400/0400H/0600/0600H/0800/0800H rack.

Rack references	a in mm	a in in.
BMXXBP0400 and BMXXBP0400H	242.4	09.54
BMXXBP0600 and BMXXBP0600H	307.6	12.11
BMXXBP0800 and BMXXBP0800H	372.8	14.68
BMXXBP1200 and BMXXBP1200H	503.2	19.81

Wiring Diagram

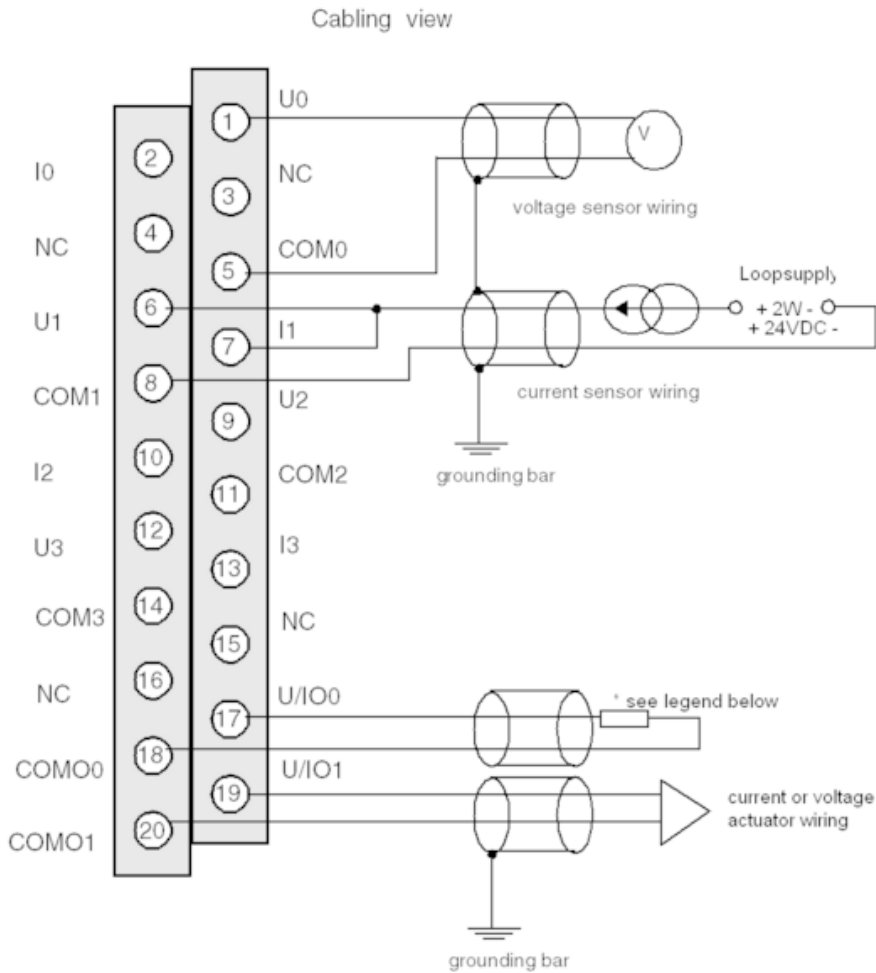

Ux + pole input for channel x

COMx - pole input for channel x

U/IOx + pole output for channel x

COMOx - pole output for channel x

* The current loop is self-powered by the output and does not request any external supply.