

SLEEVE OPENING

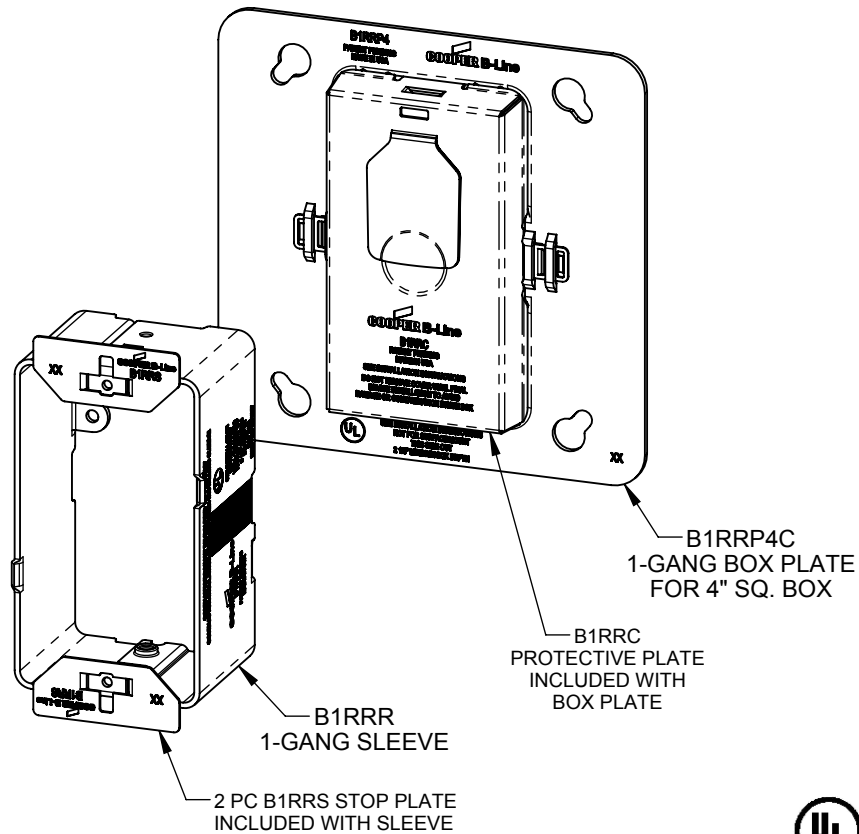

- FOR USE WITH 4" SQ. X 2 1/8" (MIN.) DEEP ELECTRICAL BOX.
- WALL THICKNESS RANGE: 1/2" - 1 1/4".
- USE OPTIONAL SLEEVE EXTENDER B1RRE FOR WALLS THICKER THAN 1 1/4" AND UP TO 2" THICK (SOLD SEPARATELY, REF. S00017038)
- SNAP-IN PROTECTIVE PLATE PROVIDES GUIDE FOR DRYWALL ROUTER AND PROTECTS INTERIOR OF ELECTRICAL BOX FROM DAMAGE AND DEBRIS DURING WALL FINISHING

THIS DRAWING AND/OR THE TECHNICAL INFORMATION CONTAINED HEREON IS THE PROPERTY OF COOPER B-LINE, INC. ("B-LINE"), AND IS ISSUED IN CONFIDENCE FOR B-LINE ENGINEERING PURPOSES ONLY AND MAY NOT BE REPRODUCED OR USED FOR ANY PURPOSE WHATSOEVER WITHOUT THE EXPRESS WRITTEN PERMISSION OF B-LINE TO THE USER. THIS DRAWING AND/OR TECHNICAL INFORMATION IS THE PROPERTY OF B-LINE AND IS LOANED FOR MUTUAL ASSISTANCE. TO BE RETURNED WHEN ITS INTENDED PURPOSE HAS BEEN SERVED.

<p>509 W. Monroe Street Highland, IL 62249 Phone (618) 654-2184 FAX (618) 654-5499 www.cooperbline.com</p>	SUBMITTAL DRAWING		REFERENCE DWG(S): S00017038	SUBMITTAL NO: S00017040A
	TITLE: RAPID RING KIT 1-GANG, 4" SQ BOX B1RR4			DRAWN BY: MLW REV. A DATE: 06/01/11
			MODEL SOURCE FILE: 00017040 REV: 00	SHEET: 1 OF 1
	<small>EQUIPMENT FURNISHED HAS BEEN FABRICATED IN ACCORDANCE WITH THIS DRAWING.</small>			

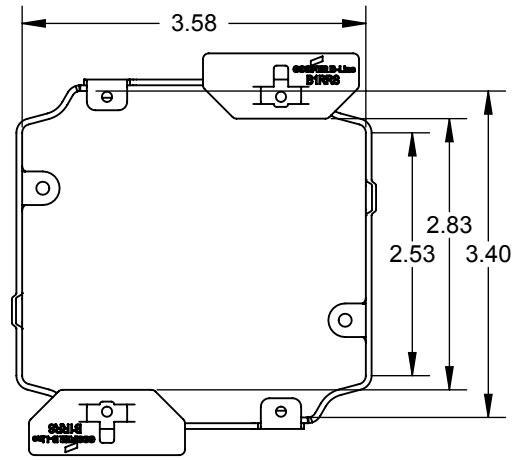

SLEEVE OPENING

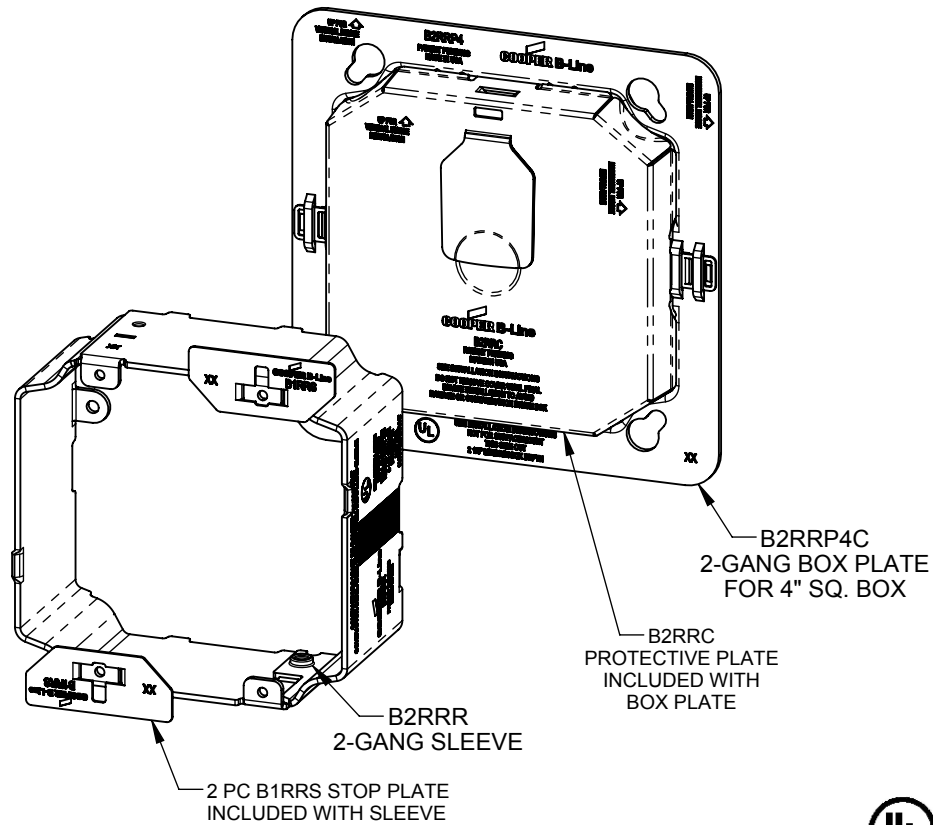

- FOR USE WITH 4" SQ. X 2 1/8" (MIN.) DEEP ELECTRICAL BOX.
- WALL THICKNESS RANGE: 1/2" - 1 1/4".
- USE OPTIONAL SLEEVE EXTENDER B2RRE FOR WALLS THICKER THAN 1 1/4" AND UP TO 2" THICK (SOLD SEPARATELY, REF. S00017038)
- SNAP-IN PROTECTIVE PLATE PROVIDES GUIDE FOR DRYWALL ROUTER AND PROTECTS INTERIOR OF ELECTRICAL BOX FROM DAMAGE AND DEBRIS DURING WALL FINISHING

THIS DRAWING AND/OR THE TECHNICAL INFORMATION CONTAINED HEREON IS THE PROPERTY OF COOPER B-LINE, INC. ("B-LINE"), AND IS ISSUED IN CONFIDENCE FOR B-LINE ENGINEERING PURPOSES ONLY AND MAY NOT BE REPRODUCED OR USED FOR ANY PURPOSE WHATSOEVER WITHOUT THE EXPRESS WRITTEN PERMISSION OF B-LINE TO THE USER. THIS DRAWING AND/OR TECHNICAL INFORMATION IS THE PROPERTY OF B-LINE AND IS LOANED FOR MUTUAL ASSISTANCE. TO BE RETURNED WHEN ITS INTENDED PURPOSE HAS BEEN SERVED.

<p>509 W. Monroe Street Highland, IL 62249 Phone (618) 654-2184 FAX (618) 654-5499 www.cooperbline.com</p>	SUBMITTAL DRAWING		REFERENCE DWG(S): S00017038	SUBMITTAL NO: S00017040B
	TITLE: RAPID RING KIT 2-GANG, 4" SQ BOX B2RR4			DRAWN BY: MLW REV. A DATE: 06/01/11
			MODEL SOURCE FILE: 00017040 REV: 00	SHEET: 1 OF 1
	<small>EQUIPMENT FURNISHED HAS BEEN FABRICATED IN ACCORDANCE WITH THIS DRAWING.</small>			

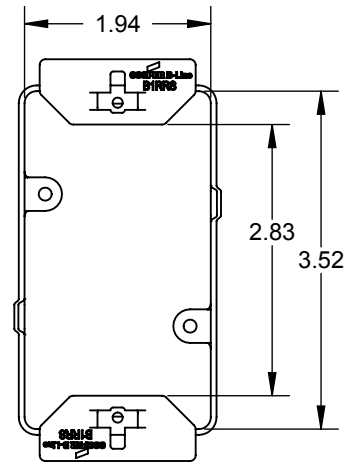

SLEEVE OPENING

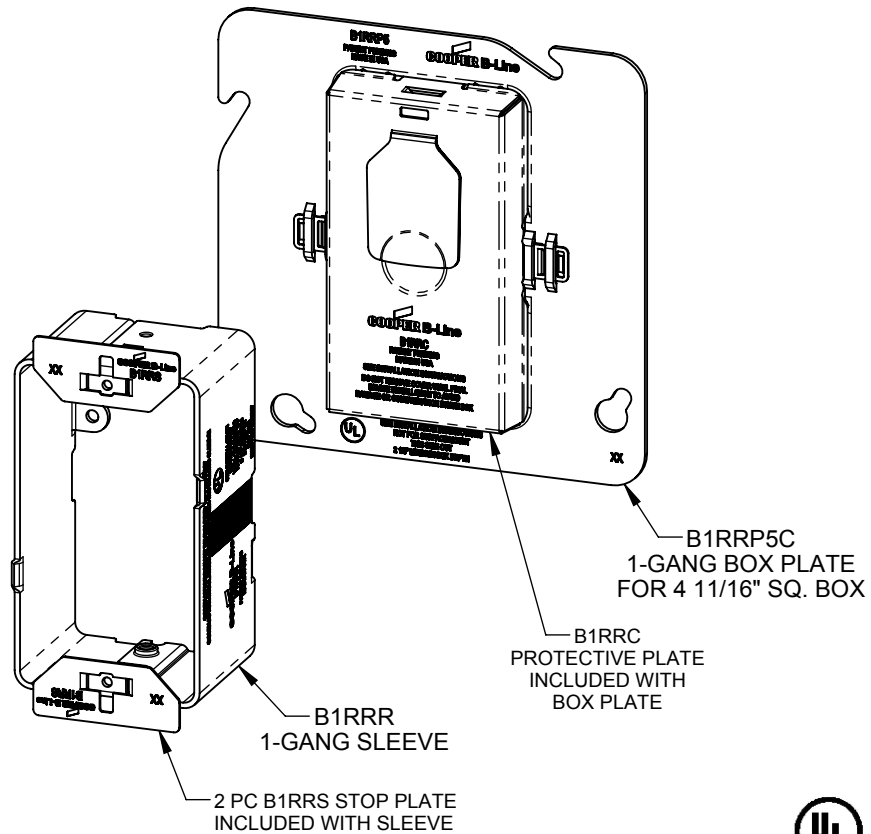

- FOR USE WITH 4 11/16" SQ. X 2 1/8" (MIN.) DEEP ELECTRICAL BOX.
- WALL THICKNESS RANGE: 1/2" - 1 1/4".
- USE OPTIONAL SLEEVE EXTENDER B1RRE FOR WALLS THICKER THAN 1 1/4" AND UP TO 2" THICK (SOLD SEPARATELY, REF. S00017038)
- SNAP-IN PROTECTIVE PLATE PROVIDES GUIDE FOR DRYWALL ROUTER AND PROTECTS INTERIOR OF ELECTRICAL BOX FROM DAMAGE AND DEBRIS DURING WALL FINISHING

THIS DRAWING AND/OR THE TECHNICAL INFORMATION CONTAINED HEREON IS THE PROPERTY OF COOPER B-LINE, INC. ("B-LINE"), AND IS ISSUED IN CONFIDENCE FOR B-LINE ENGINEERING PURPOSES ONLY AND MAY NOT BE REPRODUCED OR USED FOR ANY PURPOSE WHATSOEVER WITHOUT THE EXPRESS WRITTEN PERMISSION OF B-LINE TO THE USER. THIS DRAWING AND/OR TECHNICAL INFORMATION IS THE PROPERTY OF B-LINE AND IS LOANED FOR MUTUAL ASSISTANCE. TO BE RETURNED WHEN ITS INTENDED PURPOSE HAS BEEN SERVED.

<p>509 W. Monroe Street Highland, IL 62249 Phone (618) 654-2184 FAX (618) 654-5499 www.cooperbline.com</p>	SUBMITTAL DRAWING		REFERENCE DWG(S):	SUBMITTAL NO:	
	TITLE: RAPID RING KIT 1-GANG, 4 11/16" SQ BOX B1RR5		S00017038	S00017040C	
			MODEL SOURCE FILE:	REV:	DRAWN BY: REV.
			00017040	00	MLW A
				DATE: 06/01/11	
				SHEET: 1 OF 1	
<small>EQUIPMENT FURNISHED HAS BEEN FABRICATED IN ACCORDANCE WITH THIS DRAWING.</small>					

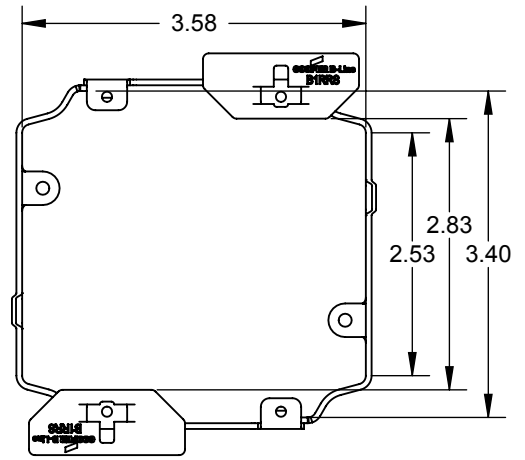

SLEEVE OPENING

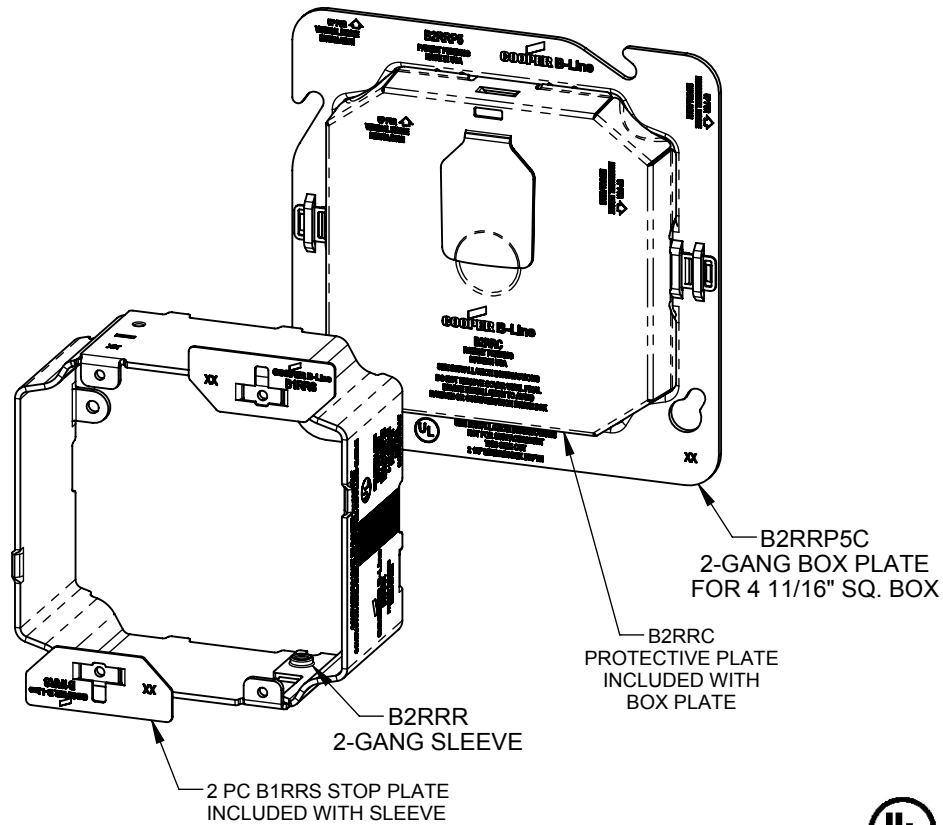

- FOR USE WITH 4 11/16" SQ. X 2 1/8" (MIN.) DEEP ELECTRICAL BOX.
- WALL THICKNESS RANGE: 1/2" - 1 1/4".
- USE OPTIONAL SLEEVE EXTENDER B2RRE FOR WALLS THICKER THAN 1 1/4" AND UP TO 2" THICK (SOLD SEPARATELY, REF. S00017038)
- SNAP-IN PROTECTIVE PLATE PROVIDES GUIDE FOR DRYWALL ROUTER AND PROTECTS INTERIOR OF ELECTRICAL BOX FROM DAMAGE AND DEBRIS DURING WALL FINISHING

THIS DRAWING AND/OR THE TECHNICAL INFORMATION CONTAINED HEREON IS THE PROPERTY OF COOPER B-LINE, INC. ("B-LINE"), AND IS ISSUED IN CONFIDENCE FOR B-LINE ENGINEERING PURPOSES ONLY AND MAY NOT BE REPRODUCED OR USED FOR ANY PURPOSE WHATSOEVER WITHOUT THE EXPRESS WRITTEN PERMISSION OF B-LINE TO THE USER. THIS DRAWING AND/OR TECHNICAL INFORMATION IS THE PROPERTY OF B-LINE AND IS LOANED FOR MUTUAL ASSISTANCE. TO BE RETURNED WHEN ITS INTENDED PURPOSE HAS BEEN SERVED.

<p>509 W. Monroe Street Highland, IL 62249 Phone (618) 654-2184 FAX (618) 654-5499 www.cooperbline.com</p>	SUBMITTAL DRAWING		REFERENCE DWG(S):	SUBMITTAL NO:	
	TITLE: RAPID RING KIT 2-GANG, 4 11/16" SQ BOX B2RR5		S00017038	S00017040D	
			MODEL SOURCE FILE: 00017040	REV: 00	DRAWN BY: MLW REV: A DATE: 06/01/11
	<small>EQUIPMENT FURNISHED HAS BEEN FABRICATED IN ACCORDANCE WITH THIS DRAWING.</small>				SHEET: 1 OF 1

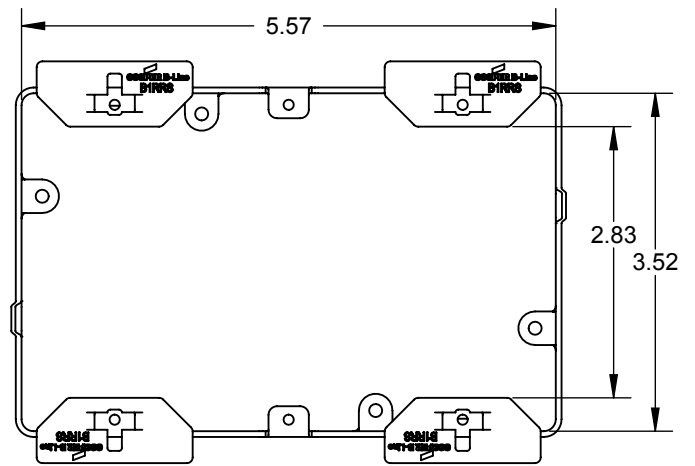

SLEEVE OPENING

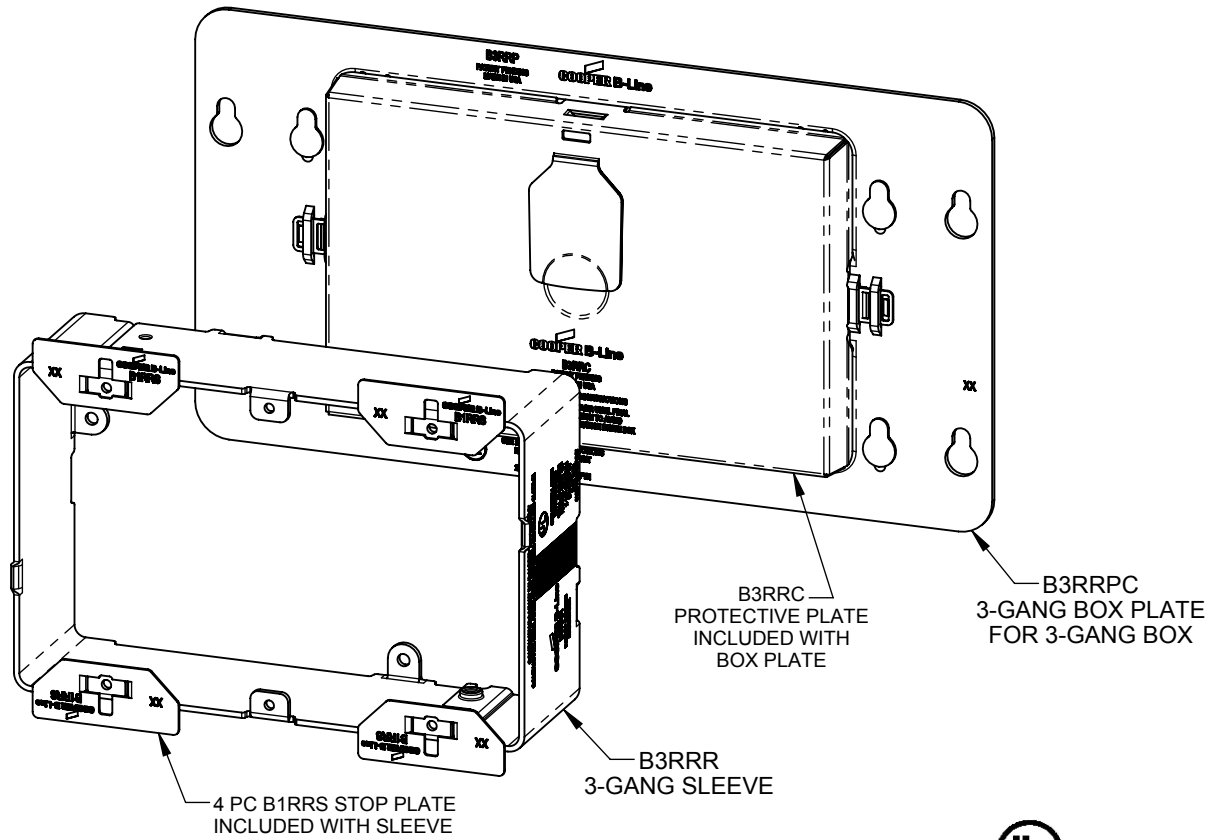

- FOR USE WITH 3-GANG X 2 1/2" (MIN.) DEEP ELECTRICAL BOX.
- KNOCK-OUTS PROVIDE OPTIONAL USE ON 2-GANG X 2 1/2" (MIN.) DEEP ELECTRICAL BOX.
- WALL THICKNESS RANGE: 1/2" - 1 1/4".
- USE OPTIONAL SLEEVE EXTENDER B3RRE FOR WALLS THICKER THAN 1 1/4" AND UP TO 2" THICK (SOLD SEPARATELY, REF. S00017038)
- SNAP-IN PROTECTIVE PLATE PROVIDES GUIDE FOR DRYWALL ROUTER AND PROTECTS INTERIOR OF ELECTRICAL BOX FROM DAMAGE AND DEBRIS DURING WALL FINISHING

THIS DRAWING AND/OR THE TECHNICAL INFORMATION CONTAINED HEREON IS THE PROPERTY OF COOPER B-LINE, INC. ("B-LINE"), AND IS ISSUED IN CONFIDENCE FOR B-LINE ENGINEERING PURPOSES ONLY AND MAY NOT BE REPRODUCED OR USED FOR ANY PURPOSE WHATSOEVER WITHOUT THE EXPRESS WRITTEN PERMISSION OF B-LINE TO THE USER. THIS DRAWING AND/OR TECHNICAL INFORMATION IS THE PROPERTY OF B-LINE AND IS LOANED FOR MUTUAL ASSISTANCE. TO BE RETURNED WHEN ITS INTENDED PURPOSE HAS BEEN SERVED.

<p>509 W. Monroe Street Highland, IL 62249 Phone (618) 654-2184 FAX (618) 654-5499 www.cooperbline.com</p>	SUBMITTAL DRAWING		REFERENCE DWG(S):	SUBMITTAL NO:	
	TITLE: RAPID RING KIT 3-GANG B3RR		S00017038	S00017040E	
			MODEL SOURCE FILE: 00017040	REV: 00	DRAWN BY: MLW DATE: 06/01/11
	<small>EQUIPMENT FURNISHED HAS BEEN FABRICATED IN ACCORDANCE WITH THIS DRAWING.</small>				REV: A SHEET: 1 OF 1

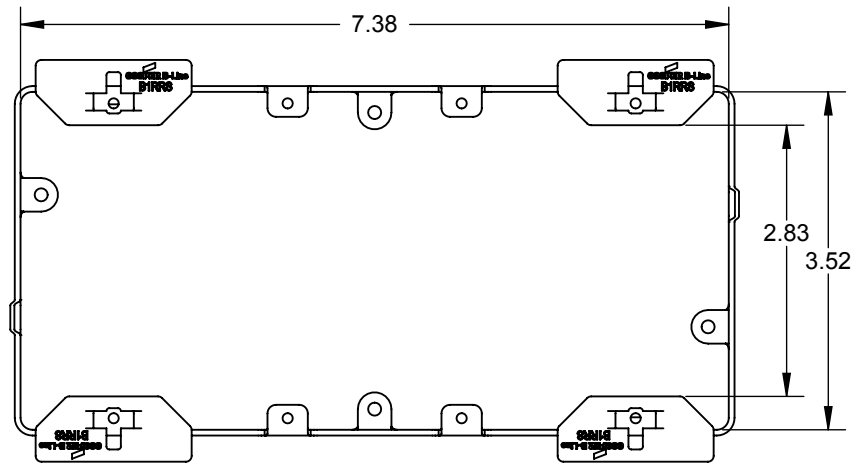

SLEEVE OPENING

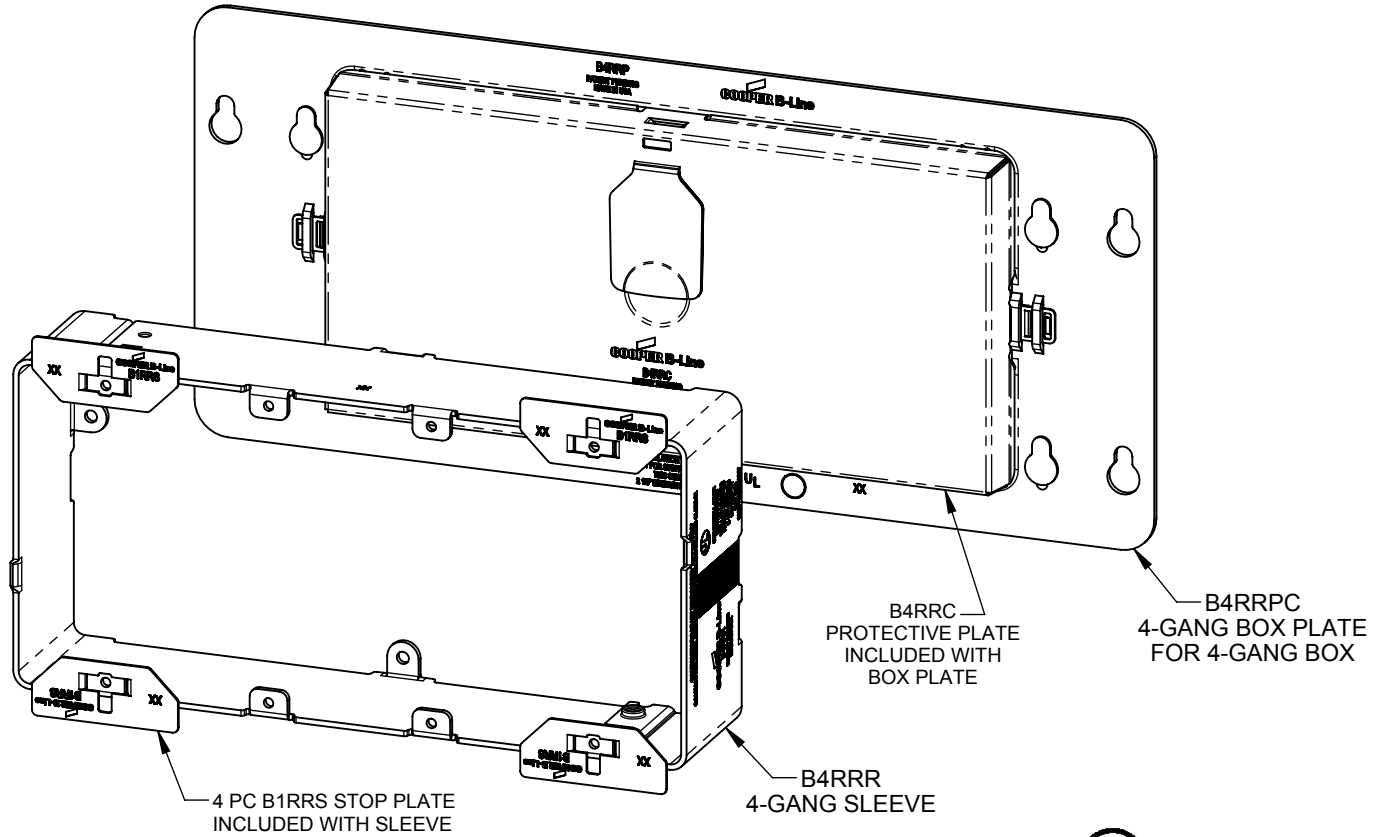

- FOR USE WITH 4-GANG X 2 1/2" (MIN.) DEEP ELECTRICAL BOX.
- KNOCK-OUTS PROVIDE OPTIONAL USE ON 3-GANG X 2 1/2" (MIN.) DEEP ELECTRICAL BOX.
- WALL THICKNESS RANGE: 1/2" - 1 1/4".
- USE OPTIONAL SLEEVE EXTENDER B4RRE FOR WALLS THICKER THAN 1 1/4" AND UP TO 2" THICK (SOLD SEPARATELY, REF. S00017038)
- SNAP-IN PROTECTIVE PLATE PROVIDES GUIDE FOR DRYWALL ROUTER AND PROTECTS INTERIOR OF ELECTRICAL BOX FROM DAMAGE AND DEBRIS DURING WALL FINISHING

THIS DRAWING AND/OR THE TECHNICAL INFORMATION CONTAINED HEREON IS THE PROPERTY OF COOPER B-LINE, INC. ("B-LINE"), AND IS ISSUED IN CONFIDENCE FOR B-LINE ENGINEERING PURPOSES ONLY AND MAY NOT BE REPRODUCED OR USED FOR ANY PURPOSE WHATSOEVER WITHOUT THE EXPRESS WRITTEN PERMISSION OF B-LINE TO THE USER. THIS DRAWING AND/OR TECHNICAL INFORMATION IS THE PROPERTY OF B-LINE AND IS LOANED FOR MUTUAL ASSISTANCE. TO BE RETURNED WHEN ITS INTENDED PURPOSE HAS BEEN SERVED.

<p>509 W. Monroe Street Highland, IL 62249 Phone (618) 654-2184 FAX (618) 654-5499 www.cooperbline.com</p>	SUBMITTAL DRAWING		REFERENCE DWG(S):	SUBMITTAL NO:	
	TITLE: RAPID RING KIT 4-GANG B4RR		S00017038	S00017040F	
			MODEL SOURCE FILE:	REV:	DRAWN BY: REV.
			00017040	00	MLW B
				DATE: 09/02/12	
				SHEET: 1 OF 1	
<small>EQUIPMENT FURNISHED HAS BEEN FABRICATED IN ACCORDANCE WITH THIS DRAWING.</small>					