

# DIMMER-DRIVER

24V Dimmer & Driver for Pinnacle Series Tape Light

## TLDDIM24V-96W

SPECIFICATION SHEET

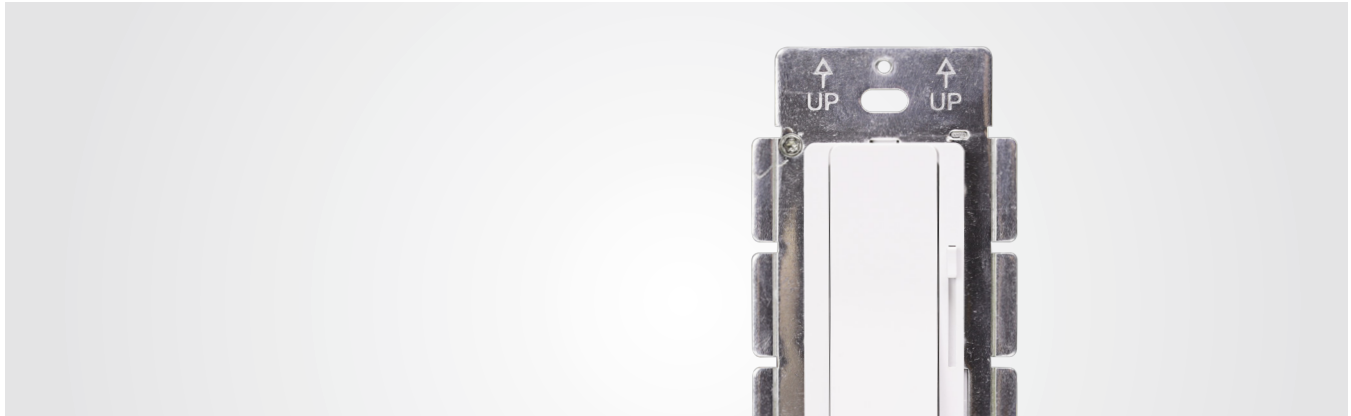

### SPECIFICATIONS

Model	TLDDIM-96W	
Certificates	UL / cUL / FCC / Class2 / Class P / SELV / RoHS / Reach	
Output	DC voltage	24V
	Rated current	4A
	Rated power	96W
	Voltage tolerance	±0.5V
Input	Voltage range	120VAC
	Frequency range	60Hz
	Power Factor (Typ.) @ full load	0.99 @ 120VAC
	THD (Typ.) @ full load	≤10%
	Efficiency (Typ.) @ full load	91%
	Inrush current (Typ.)	50A, 150us @ 50% Ipeak
	Leakage current	<0.5mA
Protection	Short circuit	Hiccup mode, recovers automatically after fault condition is removed
	Over loading	≤110% Hiccup mode, recovers automatically after fault condition is removed
	Over temperature	Shell surface temperature 100°C ± 10°C shut down o/p voltage, automatically recover after cooling
Environment	Working temperature	-40°F to 140°F (-40°C~ 60°C)
	Working humidity	20% - 95% RH, non-condensing
	Storage temperature & humidity	-40°F~ 176°F (-40°C~ 80°C) 10%~95% RH
	Vibration	10~500Hz, 2G 12min./1cycle, period for 72min. each along X,Y,Z axes
Safety & EMC	Safety Standards	UL8750 CAN/CSA-C22.2 No.250.13 (US)
Others	Net weight	0.55 lbs (0.25kg)
	Size	4.1" (105mm) (L) x 2.1" (54mm) (W) x 1.99" (51mm) (D)
	Master case	20pcs/CTN

## FINISHES

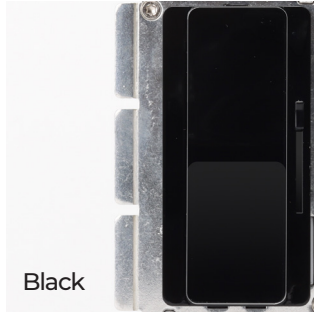

## FEATURES

- |                      |   |
|----------------------|---|
| Output:              | Constant voltage  |
| Certifications:      | UL / cUL / FCC / Class2 / Class P / SELV / RoHS / Reach   |
| Universal A/C input: | 120 VAC   |
| Power factor:        | 0.99  |
| High efficiency:     | Up to 91%   |
| Dimming range:       | 0.3%-100%   |
| Load:                | 1-100%  |
| Protection:          | Short circuit / over loading / over temperature<br>Flicker-free<br>Compatible with Pinnacle Series LED Tape Light |

## DIMENSIONS

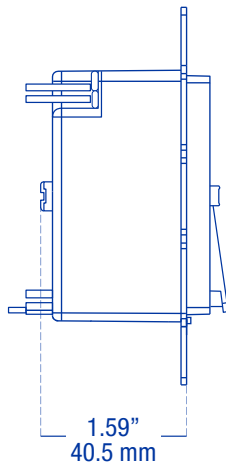
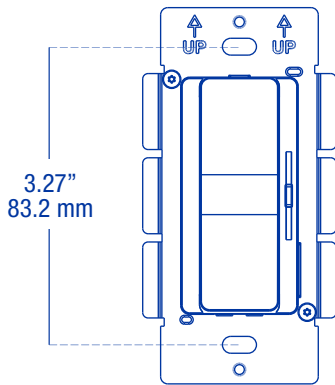

## APPLICATIONS

The 24V Dimmer + Driver simplifies LED lighting installations for any type of 24V constant voltage tape lights, whether under-cabinet or recessed. The dimmer and driver combination eliminates compatibility issues by integrating both components into a single device. It fits into a standard recessed electrical box with a smooth dimming range of 100-1%.

## RATINGS & CERTIFICATIONS



## ORDERING GUIDE

Model	Wattage	Input voltage	Output voltage	Finish
<b>TLDDIM24V</b>	<b>96W</b>	120 VAC	24V DC	White
	<b>96WB</b>	120 VAC	24V DC	Black

Note: Configure product using **BOLD** options. Ex.: **TLDDIM24V-96W**