

XB5KSM

Annunciator, Harmony XB5, Complete buzzer, plastic, 22mm, continuous or intermittent tone, 230...240V AC



Main

Range of Product	Harmony XB5
Product or Component Type	Annunciator
Bezel material	Dark grey plastic
Mounting diameter	0.87 in (22 mm)
Head type	Standard
Cap/operator or lens colour	Black

Complementary

Supply circuit type	AC
Supply frequency	50 Hz
Signalling type	Continuous or intermittent tone
Noise level	90 dB 6.8 kHz 0.1 m +/- 10 %
Resistance to high pressure washer	1305.34 psi (9000000 Pa) 176 °F (80 °C) 0.1 m
Height	1.14 in (29 mm)
Width	1.14 in (29 mm)
Depth	2.17 in (55 mm)
Net Weight	0.05 lb(US) (0.024 kg)
Current Consumption	<= 18 mA
[Us] rated supply voltage	230...240 V +/- 10 %

Environment

Protective treatment	TH
Ambient Air Temperature for Storage	-40...158 °F (-40...70 °C)
Ambient Air Temperature for Operation	-40...158 °F (-40...70 °C)
Overvoltage category	Class II IEC 60536
Electrical shock protection class	Class II IEC 60536
NEMA Degree of Protection	NEMA 4X NEMA 13
Standards	IEC 60947-5-1 IEC 60947-5-4 UL 508 JIS C8201-5-1 IEC 60947-5-1 IEC 60947-1 CSA C22.2 No 14 IEC 60947-5-4 IEC 60947-1 JIS C8201-1 IEC 60529 IEC 62262 IEC 50102
Product Certifications	UL Listed[RETURN]CSA[RETURN]BV

The information provided in this documentation contains general descriptions and/or technical characteristics of the performance of the products contained herein. This documentation is not intended as a substitute for and is not to be used for determining suitability or reliability of these products for specific user applications. It is the duty of any such user or integrator to perform the appropriate and complete risk analysis, evaluation and testing of the products with respect to the relevant specific application or use thereof. Neither Schneider Electric Industries SAS nor any of its affiliates or subsidiaries shall be responsible or liable for misuse of the information contained herein.

Ordering and shipping details

Category	22467-PUSHBUTTONS,22MM(PLASTIC) NEW
Discount Schedule	CS2
GTIN	3389110102697
Returnability	No
Country of origin	FR

Packing Units

Unit Type of Package 1	PCE
Number of Units in Package 1	1
Package 1 Height	1.34 in (3.4 cm)
Package 1 Width	1.34 in (3.4 cm)
Package 1 Length	2.24 in (5.7 cm)
Package 1 Weight	0.99 oz (28.0 g)
Unit Type of Package 2	S01
Number of Units in Package 2	88
Package 2 Height	5.91 in (15.0 cm)
Package 2 Width	5.91 in (15.0 cm)
Package 2 Length	15.75 in (40.0 cm)
Package 2 Weight	5.99 lb(US) (2.715 kg)

Offer Sustainability

Sustainable offer status	Green Premium product
California proposition 65	WARNING: This product can expose you to chemicals including: Lead and lead compounds, which is known to the State of California to cause cancer and birth defects or other reproductive harm. For more information go to www.P65Warnings.ca.gov
REACH Regulation	REACH Declaration
EU RoHS Directive	Pro-active compliance (Product out of EU RoHS legal scope)
Mercury free	Yes
China RoHS Regulation	China RoHS Declaration
RoHS exemption information	Yes
Environmental Disclosure	Product Environmental Profile
Circularity Profile	No need of specific recycling operations
WEEE	The product must be disposed on European Union markets following specific waste collection and never end up in rubbish bins.

Contractual warranty

Warranty	18 months
----------	-----------

Dimensions

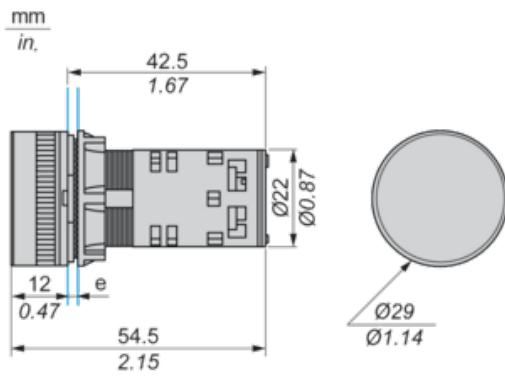

e: Clamping thickness: 1 to 6 mm / 0.04 to 0.24 in.

Panel Cut-out for Buzzer

Connection by Screw Clamp Terminals



(1) Diameter on finished panel or support

(2) Ø22.5 mm recommended ($\text{Ø}22.3 \text{ }_0^{+0.4}$) / Ø0.89 in. recommended ($\text{Ø}0.88 \text{ in. }_0^{+0.016}$)

Connections	a in mm	a in in.	b in mm	b in in.
By screw clamp terminals or plug-in connector	40	1.57	30	1.18

Cabling of Annunciators

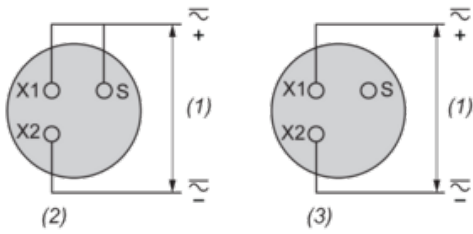

- (1) Supply
- (2) Intermittent
- (3) Continuous