

XPSMCMC10804BG

safety controller, Modicon MCM, 8 inputs 4 outputs, combined with backplane expansion connector, spring



Main

Range of Product	Modicon Safety automation
Product or Component Type	Modular safety controller CPU kit
Device short name	XPSMCM
Electrical Connection	Spring terminal
[Us] rated supply voltage	24 V - 20...20 % DC
Number of inputs	8.0 digital input connection 4.0 digital interlock start/restart or external device monitoring
Number of outputs	4.0 safety outputs OSSD contactor/drive connection 4.0 test line control outputs 4.0 configurable diagnostic connection
Discrete input voltage	24 V
Discrete output current	400 mA
Discrete input current	400 mA
Discrete input type	Safety input PNP
Discrete output type	PNP
Kit composition	1 safety controller CPU 1 backplane expansion connector
Function of module	Emergency stop ISO 13850 Guard monitoring EN/ISO 14119 Enabling switch monitoring IEC 60947-5-1 Light curtain monitoring IEC 61496-1 Foot switch monitoring IEC 60947-5-1 Light curtain monitoring EN/ISO 14119 Switch monitoring EN 574 Two-hand control EN/ISO 14119 Safety mat monitoring IEC 61326-1 Switch monitoring IEC 61800-5-2 Muting function of light curtains IEC 61800-5-2 Safety time delays Counter functions

Complementary

Synchronisation time between inputs	< 0.5 ms
Power dissipation in W	3 W
Maximum number of I/O expansion module	14 128 input 14 32.0 output
Integrated connection type	Backplane expansion bus USB 2.0 port
Data storage equipment	SD card optional)
Inductive load	2.4 mH
Load capacitance	0.82 µF
Safety level	Can reach category 4 ISO 13849-1 Can reach PL = e ISO 13849-1 Type 4 IEC 61496-1 SILCL 3 IEC 62061
Quality labels	CE

The information provided in this documentation contains general descriptions and/or technical characteristics of the performance of the products contained herein. This documentation is not intended as a substitute for and is not to be used for determining suitability or reliability of these products for specific user applications. It is the duty of any such user or integrator to perform the appropriate and complete risk analysis, evaluation and testing of the products with respect to the relevant specific application or use thereof. Neither Schneider Electric Industries SAS nor any of its affiliates or subsidiaries shall be responsible or liable for misuse of the information contained herein.

Local signalling	1 LED green PWR power ON 1 LED green RUN RUN (status) 1 LED red E IN internal error 1 LED red E EX external error 1 LED orange COM communication 1 LED blue EN master enable 8 LEDs yellow IN input status 2 LEDs green/red OUT output status 2 LEDs yellow RST restart signal 2 LEDs yellow STATUS output channel
Connections - terminals	2 spring terminals, removable terminal block 1 spring terminals, removable terminal block
Cable cross section	0.00...0.00 In ² (0.2...1.5 mm ²) - AWG 24...AWG 16 flexible without cable end 0.00...0.00 In ² (0.2...2.5 mm ²) - AWG 24...AWG 14 flexible without cable end 0.00...0.00 In ² (0.25...1 mm ²) - AWG 23...AWG 18 flexible with cable end, without bezel 0.00...0.00 In ² (0.25...2.5 mm ²) - AWG 23...AWG 14 flexible with cable end, with bezel 0.00...0.00 In ² (0.25...1.5 mm ²) - AWG 23...AWG 16 flexible with cable end, without bezel 0.00...0.00 In ² (0.5...1.5 mm ²) - AWG 20...AWG 16 flexible with cable end, with double bezel 0.00...0.00 In ² (0.2...1 mm ²) - AWG 24...AWG 18 solid without cable end 0.00...0.00 in ² (0.2...2.5 mm ²) - AWG 24...AWG 14 solid without cable end
Mounting support	Omega 35 mm DIN rail EN 50022
Depth	4.51 in (114.5 mm)
Height	3.90 in (99 mm)
Width	0.89 in (22.5 mm)
Net Weight	0.34 lb(US) (0.155 kg)

Environment

Standards	IEC 61496-1 ISO 13849-1 IEC 61508 IEC 61800-5-1 IEC 62061
Product Certifications	TÜV[RETURN]RCM[RETURN]cULus
IP degree of protection	IP20
Ambient Air Temperature for Operation	14...131 °F (-10...55 °C)
Ambient Air Temperature for Storage	-4...185 °F (-20...85 °C)
Relative humidity	10...95 %
Pollution degree	2
[Uimp] rated impulse withstand voltage	4 kV IEC 61800-5-1
Safety reliability data	PFHd = 1.35E-8 1/h high DC > 99 % MTTFd < 100 years
Insulation	250 V AC between power supply and housing IEC 61800-5-1
Overvoltage category	II
Electromagnetic compatibility	Electrostatic discharge immunity test - test level: 6 kV (on contact) conforming to IEC 61000-4-2 Electrostatic discharge immunity test - test level: 20 kV (on air) conforming to IEC 61000-4-2 Susceptibility to electromagnetic fields - test level: 10 V/m (80...1000 MHz) conforming to IEC 61000-4-3 Susceptibility to electromagnetic fields - test level: 30 V/m (1.4 GHz...2 GHz) conforming to IEC 61000-4-3
Vibration resistance	+/-0.35 mm 10...55 Hz)IEC 61496-1
Shock resistance	10 gn 16 ms) 1000 shocks on each axis IEC 61496-1
Service Life	20 year(s)

Ordering and shipping details

Category	22477-SAFETY MODULES (PREVENTA)
Discount Schedule	SAF2
GTIN	3606481987082
Returnability	No
Country of origin	IT

Packing Units

Unit Type of Package 1	PCE
Number of Units in Package 1	1
Package 1 Height	1.77 in (4.5 cm)
Package 1 Width	5.04 in (12.8 cm)
Package 1 Length	6.46 in (16.4 cm)
Package 1 Weight	9.24 oz (262.0 g)
Unit Type of Package 2	S01
Number of Units in Package 2	6
Package 2 Height	5.91 in (15.0 cm)
Package 2 Width	5.91 in (15.0 cm)
Package 2 Length	15.75 in (40.0 cm)
Package 2 Weight	4.05 lb(US) (1.838 kg)

Offer Sustainability

Sustainable offer status	Green Premium product
California proposition 65	WARNING: This product can expose you to chemicals including: Lead and lead compounds, which is known to the State of California to cause cancer and birth defects or other reproductive harm. For more information go to www.P65Warnings.ca.gov
REACH Regulation	REACH Declaration
REACH free of SVHC	Yes
EU RoHS Directive	Pro-active compliance (Product out of EU RoHS legal scope)
Mercury free	Yes
China RoHS Regulation	China RoHS Declaration
RoHS exemption information	Yes
Environmental Disclosure	Product Environmental Profile
Circularity Profile	End Of Life Information
WEEE	The product must be disposed on European Union markets following specific waste collection and never end up in rubbish bins.

Dimensions

Spring Terminal

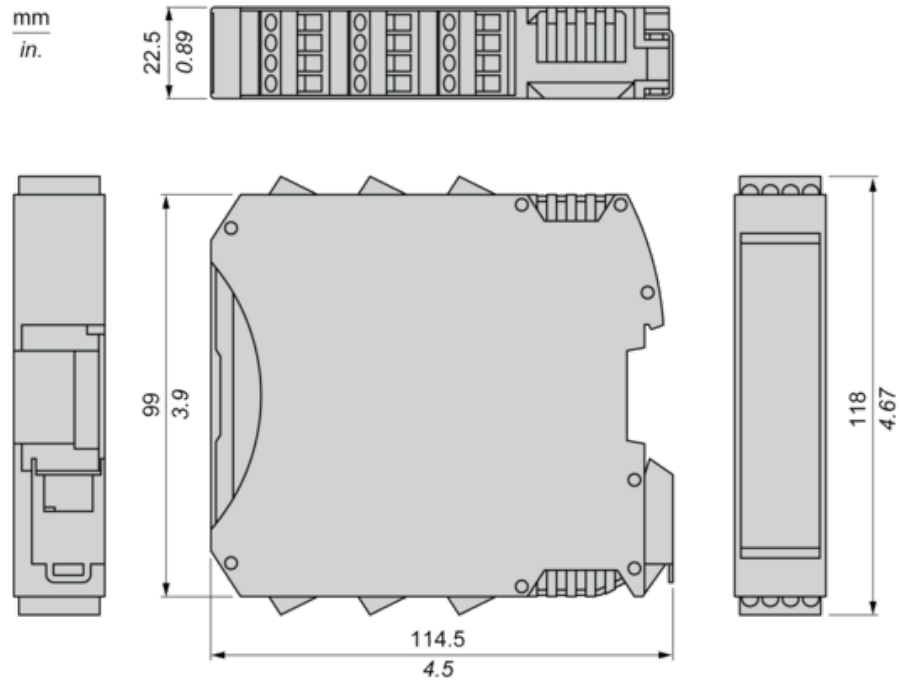

Mounting Safety Controller CPU with Module(s)

Mount BackPlane Connector on Rail

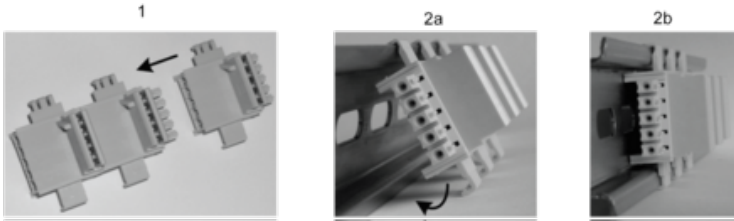

- 1 : Connect as much Backplane Connector as module to be install.
- 2 : Fix the connectors to the rail (Top first).

Mount Safety Controller CPU with Other Module(s)

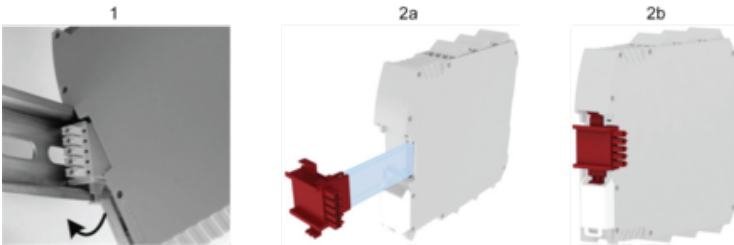

- 1 : Mount controller CPU and modules on rail.
- 2 : Make sure that the controller CPU or the module(s) are plugged on the BackPlane connector.

Wiring

Terminal Designation

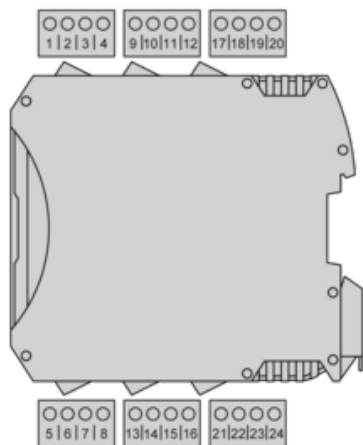

Terminal	Signal	Description
1	24 VDC	24 Vdc power supply
2	NC	–
3	NC	–
4	0 VDC	0 Vdc power supply
5	OSSD1	Safety-related output 1
6	OSSD2	Safety-related output 2
7	RESTART_FBK1/ STATUS1	Feedback/Restart 1 for OSSD1
Configurable output 1 for OSSD1		
8	RESTART_FBK2/ STATUS2	Feedback/Restart 2 for OSSD2
Configurable output 2 for OSSD2		
9	OSSD3	Safety-related output 3
10	OSSD4	Safety-related output 4
11	RESTART_FBK3/ STATUS3	Feedback/Restart 3 for OSSD3
Configurable output 3 for OSSD3		
12	RESTART_FBK4/ STATUS4	Feedback/Restart 4 for OSSD2
Configurable output 4 for OSSD2		
13	OUT_TEST1	Test output for detection of short circuits/cross circuits in input circuits
14	OUT_TEST2	
15	OUT_TEST3	
16	OUT_TEST4	
17	INPUT1	Safety-related input 1
18	INPUT2	Safety-related input 2
19	INPUT3	Safety-related input 3
20	INPUT4	Safety-related input 4

Terminal	Signal	Description
21	INPUT5	Safety-related input 5
22	INPUT6	Safety-related input 6
23	INPUT7	Safety-related input 7
24	INPUT8	Safety-related input 8

Wiring Example

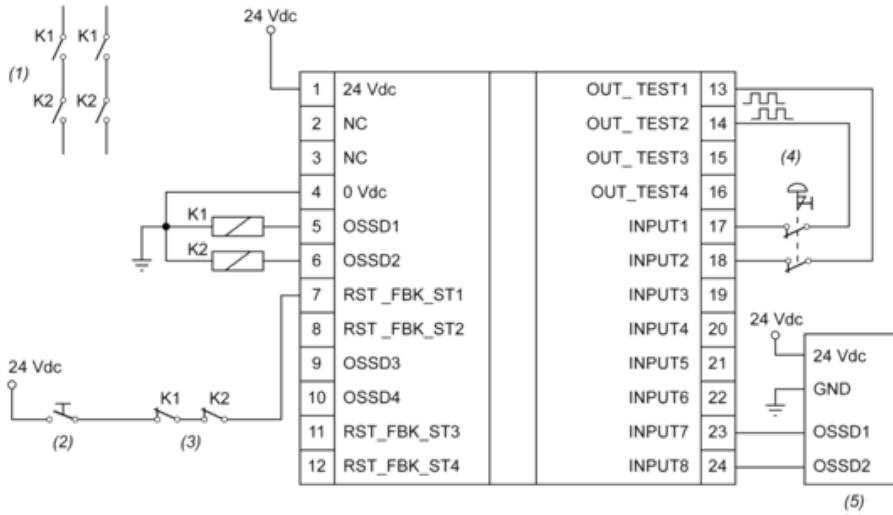

- (1) : Contactors
- (2) : Restart
- (3) : Feedback
- (4) : Emergency stop
- (5) : Light curtain