

# XPSBAT12A1AP

safety module, Harmony XPS, time delayed output, for Estop, guard, OSSD, 24V AC or DC, screw



## Main

Range of Product	Harmony Safety Automation
Product or Component Type	Safety module
Safety module name	XPSBAT
Safety module application	For emergency stop and protective guard applications For OSSD monitoring
Function of module	Emergency stop button with 2 NC contacts Guard monitoring with 1 or 2 limit switches Light curtain monitoring RFID switch Monitoring of electro-sensitive protection equipment (ESPE)
Safety level	Can reach PL e/category 4 for normally open relay contact ISO 13849-1 Can reach SILCL 3 for normally open relay contact IEC 62061 Can reach SIL 3 for normally open relay contact IEC 61508 Can reach PL c/category 1 for normally closed relay contact ISO 13849-1 Can reach SILCL 1 for normally closed relay contact IEC 62061 Can reach SIL 1 for normally closed relay contact IEC 61508
Safety reliability data	MTTFd > 30 years ISO 13849-1 Dcavg >= 99 % ISO 13849-1 PFHd = 0.98E-09 for SS0 ISO 13849-1 PFHd = 0.96E-09 for SS1 ISO 13849-1 HFT = 1 IEC 62061 PFHd = 0.98E-09 for SS0 IEC 62061 PFHd = 0.96E-09 for SS1 IEC 62061 SFF > 99% IEC 62061 HFT = 1 IEC 61508-1 PFHd = 0.98E-09 for SS0 IEC 61508-1 PFHd = 0.96E-09 for SS1 IEC 61508-1 SFF > 99% IEC 61508-1 Type = B IEC 61508-1
Electrical circuit type	NC pair OSSD pair
Connections - terminals	Removable screw terminal block, 0.2...2.5 mm <sup>2</sup> solid or flexible Removable screw terminal block, 0.25...2.5 mm <sup>2</sup> flexible with ferrule single conductor Removable screw terminal block, 0.2...1.5 mm <sup>2</sup> solid or flexible twin conductor Removable screw terminal block, 2 x 0.25...1 mm <sup>2</sup> flexible with ferrule without cable end, with bezel Removable screw terminal block, 2 x 0.5...1.5 mm <sup>2</sup> flexible with ferrule with cable end, with bezel
[Us] Rated Supply Voltage	24 V AC - 15...10 % 24 V DC - 20...20 %

The information provided in this documentation contains general descriptions and/or technical characteristics of the performance of the products contained herein. This documentation is not intended as a substitute for and is not to be used for determining suitability or reliability of these products for specific user applications. It is the duty of any such user or integrator to perform the appropriate and complete risk analysis, evaluation and testing of the products with respect to the relevant specific application or use thereof. Neither Schneider Electric Industries SAS nor any of its affiliates or subsidiaries shall be responsible or liable for misuse of the information contained herein.

## Complementary

Synchronisation time between inputs	0.5 s 2 s
Type of start	Automatic/manual/monitored
Power consumption in W	2 W 24 V DC
Power consumption in VA	5 VA 24 V AC 50/60 Hz
Input protection type	Internal, electronic
Safety outputs	2 NO immediate 1 NO configurable
Safety inputs	2 positive safety input 24 V DC 5 mA
Maximum wire resistance	500 Ohm
Time delay range	0...900 s off
Input compatibility	Normally closed circuit ISO 14119 Mechanical contact ISO 14119 OSSD pair IEC 61496-1-2 Normally closed circuit ISO 13850 3-wire proximity sensors PNP
[Ie] rated operational current	5 A AC-1 for normally open relay contact 3 A AC-15 for normally open relay contact 5 A DC-1 for normally open relay contact 3 A DC-13 for normally open relay contact
Control outputs	3 on/off configurable pulsed output
Input/output type	Semiconductor output 24 V DC, 20 mA Z1, not safety-related
[Ith] conventional free air thermal current	12 A
Associated fuse rating	6 A gG NO relay output circuit IEC 60947-1
Minimum output current	20 mA relay output
Minimum output voltage	24 V relay output
Maximum response time on input open	20 ms
[Ui] rated insulation voltage	250 V 2)IEC 60947-1
[Uimp] rated impulse withstand voltage	4 kV II IEC 60947-1
Local signalling	LED green power power ON LED red error error LED yellow state 1 safety output instantaneous LED yellow state 2 safety output delayed LED yellow start 1 start LED yellow start 2 start LED yellow S12 safety input S12 LED yellow S22 safety input S22
Mounting Support	35 mm symmetrical DIN rail
Depth	4.72 in (120 mm)
Height	3.94 in (100 mm)
Width	0.89 in (22.5 mm)
Net Weight	0.77 lb(US) (0.350 kg)

## Environment

Standards	IEC 60947-5-1 IEC 61508-1 functional safety standard IEC 61508-2 functional safety standard IEC 61508-3 functional safety standard IEC 61508-4 functional safety standard IEC 61508-5 functional safety standard IEC 61508-6 functional safety standard IEC 61508-7 functional safety standard ISO 13849-1 functional safety standard IEC 62061 functional safety standard
Product Certifications	TÜV[RETURN]cULus
IP degree of protection	IP20 terminals)IEC 60529 IP40 housing)IEC 60529 IP54 mounting area)IEC 60529
Ambient air temperature for operation	-13...131 °F (-25...55 °C)
Ambient Air Temperature for Storage	-13...185 °F (-25...85 °C)
Relative Humidity	5...95 % non-condensing

## Ordering and shipping details

Category	22477-SAFETY MODULES (PREVENTA)
Discount Schedule	SAF2
GTIN	3606482034044
Returnability	Yes

## Packing Units

Unit Type of Package 1	PCE
Number of Units in Package 1	1
Package 1 Height	2.68 in (6.8 cm)
Package 1 Width	5.43 in (13.8 cm)
Package 1 Length	6.10 in (15.5 cm)
Package 1 Weight	10.12 oz (287.0 g)
Unit Type of Package 2	S03
Number of Units in Package 2	16
Package 2 Height	11.81 in (30 cm)
Package 2 Width	11.81 in (30 cm)
Package 2 Length	15.75 in (40 cm)
Package 2 Weight	11.71 lb(US) (5.312 kg)

## Offer Sustainability

Sustainable offer status	Green Premium product
California proposition 65	WARNING: This product can expose you to chemicals including: Lead and lead compounds, which is known to the State of California to cause cancer and birth defects or other reproductive harm. For more information go to <a href="http://www.P65Warnings.ca.gov">www.P65Warnings.ca.gov</a>
REACH Regulation	<a href="#">REACH Declaration</a>
EU RoHS Directive	Pro-active compliance (Product out of EU RoHS legal scope)
Mercury free	Yes
China RoHS Regulation	<a href="#">China RoHS Declaration</a>
RoHS exemption information	<a href="#">Yes</a>
Environmental Disclosure	<a href="#">Product Environmental Profile</a>
Circularity Profile	<a href="#">End Of Life Information</a>
WEEE	The product must be disposed on European Union markets following specific waste collection and never end up in rubbish bins.

Dimensions

Front and Side Views

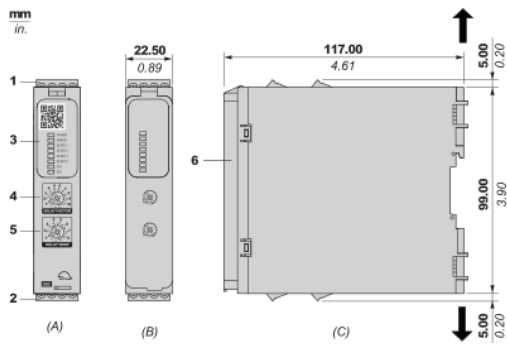

- (A) : Product drawing
- (B) : Screw clamp terminal
- (C) : Side view
- (1) : Removable terminal blocks, top
- (2) : Removable terminal blocks, bottom
- (3) : LED indicators
- (4) : Delay factor selector
- (5) : Delay base selector
- (6) : Sealable transparent cover

mm in.	7.0–8.0 0.28–0.31					
	mm <sup>2</sup>	0,2... 2,5	0,25...2,5	0,2...1,5	0,25...1	0,5...1,5
	AWG	24... 12	24...12	24...16	24...18	20...16
	 Ø 3,5 mm (0.14 in)				Nm	0.5... 0.6
					lb-in	4,4... 5,3

## Mounting to DIN rail

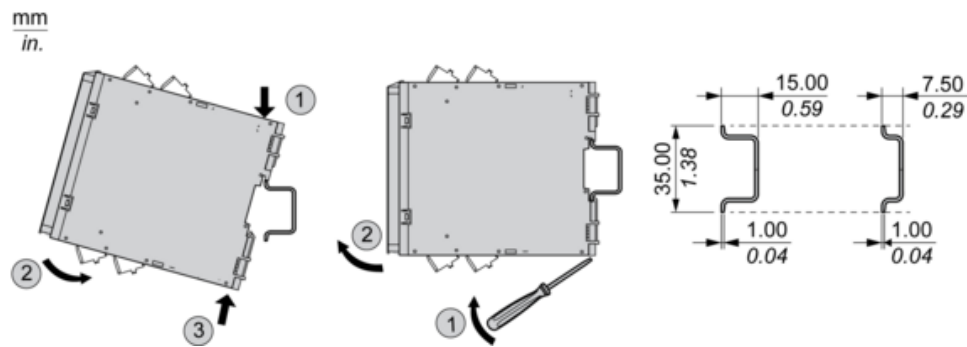

## Screw-mounting

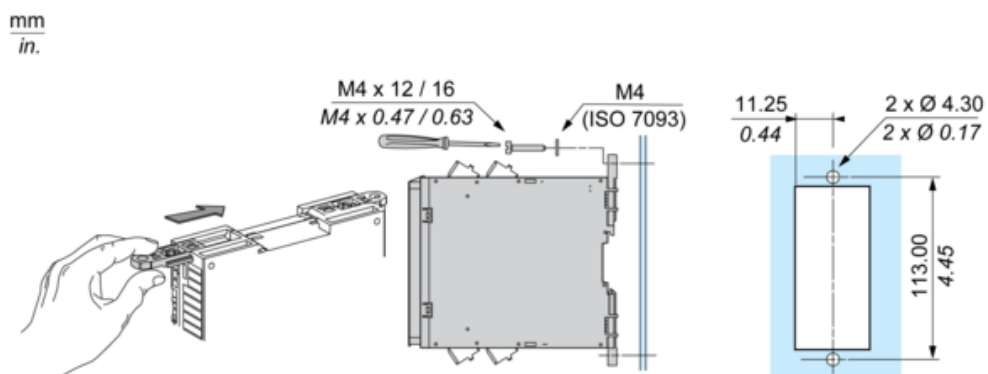

## Wiring Diagram

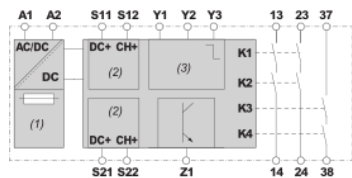

(1) : A1-A2 (Power supply)

(2) : S11–S21 (Control outputs (DC+) of safety-related inputs), S12-S22 (Input channels (CH+) of safety-related inputs)

(3) : Y1 (Control output of Start/Restart input), Y2 (Input channel for automatic/manual start), Y3 (Input channel for monitored start with falling edge)

13-14-23-24 : Terminals of the safety-related outputs (instantaneous)

37-38 : Terminals of the safety-related outputs (delayed)

Z1 : Solid state output, not safety-related