

ORDERING INFORMATION

Order code: 62941
 Description: BMH0070/QUADTAP/C/HX/H/K/STD
 UPC: 69549629417



SPECIFICATIONS

Ballast type: Magnetic metal halide
 Ballast style: Core and coil
 Circuit type: HX-HPF
 ANSI code: M98
 Input voltage (V): 120/208/240/277
 Input frequency (Hz): 60
 Line volt regulation: 5 %
 Line watt regulation: 10 %
 Insulation class: H (180)

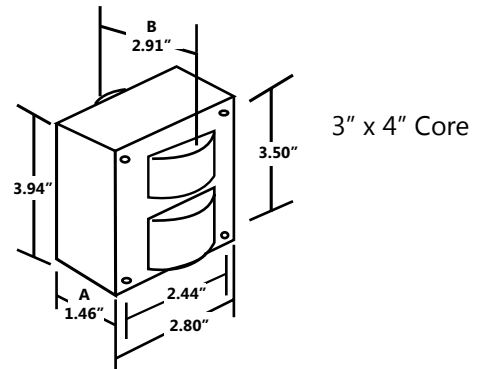

Input voltage (V)	Operating current (A)	Open circuit current (A)	Starting current (A)	Rated lamp watts (W)	Input watts (W)	OCV (V)	Dropout voltage (V)	UL 1029 code	Fuse rating (A)	Input current (A)	Power factor	Starting temperature
120	0.83	1.65	1.30	70	93	260	90	A	4	0.40-0.70	0.90	-20°F / -30°C
208	0.49	0.97	0.75	70	93	260	156	A	3	0.25-0.45	0.90	-20°F / -30°C
240	0.42	0.83	0.45	70	93	260	180	A	3	0.21-0.35	0.90	-20°F / -30°C
277	0.38	0.73	0.40	70	93	260	208	A	2	0.20-0.35	0.90	-20°F / -30°C

HIGH POTENTIAL TEST (V)

1 minute:	2 000
2 seconds:	2 500
OCV test:	230 - 280
Short circuit:	0.85 - 1.25

BALLAST DIMENSIONS

Dimension A:	1.46"
Dimension B:	2.91"
Lead lengths:	12" - 14"
Weight (lbs) :	4.63

WIRING DIAGRAM

Ground ballast core

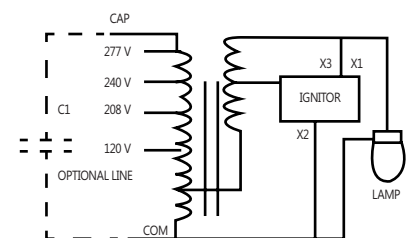

BRACKET

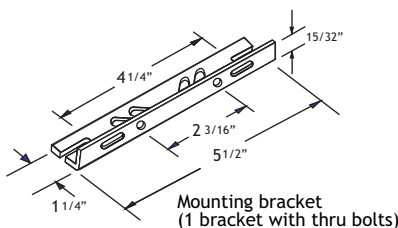

CAPACITOR

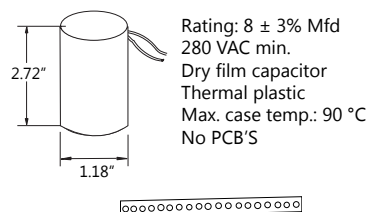

IGNITOR

