



Hammond Power  
Solutions Inc.

your *first*  
source for  
transformers



**HPS Fusion™**  
General Purpose  
Enclosed Transformer

*Other HPS Products*



[www.hammondpowersolutions.com](http://www.hammondpowersolutions.com)

# HPS Fusion™

General Purpose Enclosed  
Transformer



## OUR COMPANY

Hammond Power Solutions (HPS) was established in 1917 in Guelph, Ontario and has grown from a small family owned business in the short wave radio market, to the industry leader in magnetic transformer design and manufacturing. HPS has manufacturing facilities in Compton, California; Guelph, Ontario; Walkerton, Ontario; Granby, Quebec; and Monterrey, Mexico. HPS has multiple regional distribution centers throughout North America.

## GENERAL PURPOSE ENCLOSED TRANSFORMER

The HPS Fusion™ line of enclosed transformers are an indoor, cost effective approach ideally suited for single phase, general purpose industrial and light duty loads.

## APPLICATIONS

The HPS Fusion™ is the perfect solution and is specifically designed for the following applications:

- General purpose enclosed applications used to adjust a supply voltage to match a load requirement
- Supplying motor control circuits
- Signal and Alarm systems
- Industrial lighting and circuit isolation
- HVAC applications

## INDUSTRIES

- Commercial
- Industrial
- Security
- HVAC





## FEATURES AND BENEFITS

- Molded terminal blocks for primary and secondary connections up to 3000 VA or 30 amps. Coil face termination over 3000 VA or 30 amps.
- All terminal blocks utilize a combination slot/ Phillips #6 screw with a SEMS washer (suitable for 18 AWG to 14 AWG solid wire and 18 AWG to 12 AWG stranded wire). Units with coil face terminations utilize a ¼-20 UNC X 0.50" combination slot/ Phillips screw and a spring lock washer.
- 50/60 Hz (60 Hz on FS\*\*\*ACP and FS\*\*\*AR).
- Copper wound coils with high dielectric strength insulation.
- Bolted core construction.
- CSA Certified (file LR 3902), UL Listed (file E50394), CE Marked and RoHS Compliant.
- Meets NEMA standards.
- All HPS Fusion core and coils are Vacuum Impregnated with Polyester Resin and oven cured.
- Superior insulating materials. The HPS Fusion™ offers the following insulation systems:
  - Up to 1500 VA: 95°C temperature rise, 130°C insulation class (B)
  - 2000 VA to 5000 VA: 130°C temperature rise, 180°C insulation class (F)(Note: Temperature rise based on 25°C ambient)
- All units supplied with primary and secondary voltage links/jumpers.
- Rugged TYPE 1 enclosure.
- Finish - green powder coat.
- Primary and secondary ground screws.
- Four (0.88") wiring knockouts and four (0.50") accessory knockouts.
- Optional panel mount fuse holder.
- Easy mounting and installation via four mounting slots and two keyhole slots.
- Easy access to primary and secondary wiring compartment through removable covers.
- Most HPS Fusion units incorporate "Premium Packaging" which feature:
  - Premium fluted cartons
  - Custom molded foam inserts
  - Easy removal and repacking
  - Industry's best box label
  - Environmentally neutral
- All HPS Fusion units are supplied with trilingual installation and wiring instruction sheets.
- **15 Year Warranty.**

# HPS Fusion™

General Purpose Enclosed  
Transformer



## Group E

Primary Voltage: 380/347  
Secondary Voltage: 120 x 240



VA Rating	CE VA Rating	Catalog Number	Output Amps	Overall Dimensions			Mounting Centers		Mounting Slot	Approx. Ship Weight Lbs.
				A	B	C	D	E	G X H	
50	50	FS50KHP	0.42/0.21	2.7	5.9	3.33	1.66	3.69	0.22 x 0.44	2.5
100	100	FS100KHP	0.83/0.42	3.09	6.3	3.6	2.05	3.5	0.22 x 0.44	4.3
150	150	FS150KHP	1.25/0.63	3.09	6.9	3.6	2.05	4.1	0.22 x 0.44	5.3
250	160	FS250KHP	2.08/1.04	3.9	6.6	4.3	2.52	3.9	0.22 x 0.44	7.9
350	250	FS350KHP	2.92/1.46	3.9	7.2	4.3	2.52	4.9	0.22 x 0.44	9.6
500	300	FS500KHP	4.17/2.08	4.6	7.2	4.6	3.3	4.5	0.31 x 0.81	13.6
750	500	FS750KHP	6.25/3.13	5.6	7.2	5.1	4	4.5	0.31 x 0.81	19
1000	650	FS1000KHP	8.33/4.17	5.6	8	5.1	4	5.3	0.31 x 0.81	23.5
1500	1000	FS1500KHP	12.5/6.25	6.6	8.5	6	5.1	5.1	0.31 x 0.81	31.6

Primary and Secondary voltage links/jumpers supplied standard with all transformers.  
Special voltages and VA sizes available upon request.

All dimensions in inches

\* See page 10 for dimensional drawings.

## Group F

Primary Voltage: 380/347  
Secondary Voltage: 12 x 24



VA Rating	CE VA Rating	Catalog Number	Output Amps	Overall Dimensions			Mounting Centers		Mounting Slot	Approx. Ship Weight Lbs.
				A	B	C	D	E	G X H	
50	50	FS50KHR	4.17/2.08	2.7	5.9	3.33	1.66	3.69	0.22 x 0.44	2.5
100	100	FS100KHR	8.33/4.17	3.09	6.3	3.6	2.05	3.5	0.22 x 0.44	4.2
150	150	FS150KHR	12.5/6.25	3.09	6.9	3.6	2.05	4.1	0.22 x 0.44	5.3
250	160	FS250KHR	20.8/10.4	3.9	6.6	4.3	2.52	3.9	0.22 x 0.44	7.6
350	250	FS350KHR	29.2/14.6	3.9	7.2	4.3	2.52	4.9	0.22 x 0.44	9.3
500	300	FS500KHR	41.7/20.8	4.6	7.2	4.6	3.3	4.5	0.31 x 0.81	13.2

Primary and Secondary voltage links/jumpers supplied standard with all transformers.  
Special voltages and VA sizes available upon request.

All dimensions in inches

\* See page 10 for dimensional drawings.

# HPS Fusion™

General Purpose Enclosed  
Transformer

## DIMENSIONAL DRAWINGS

FIGURE A

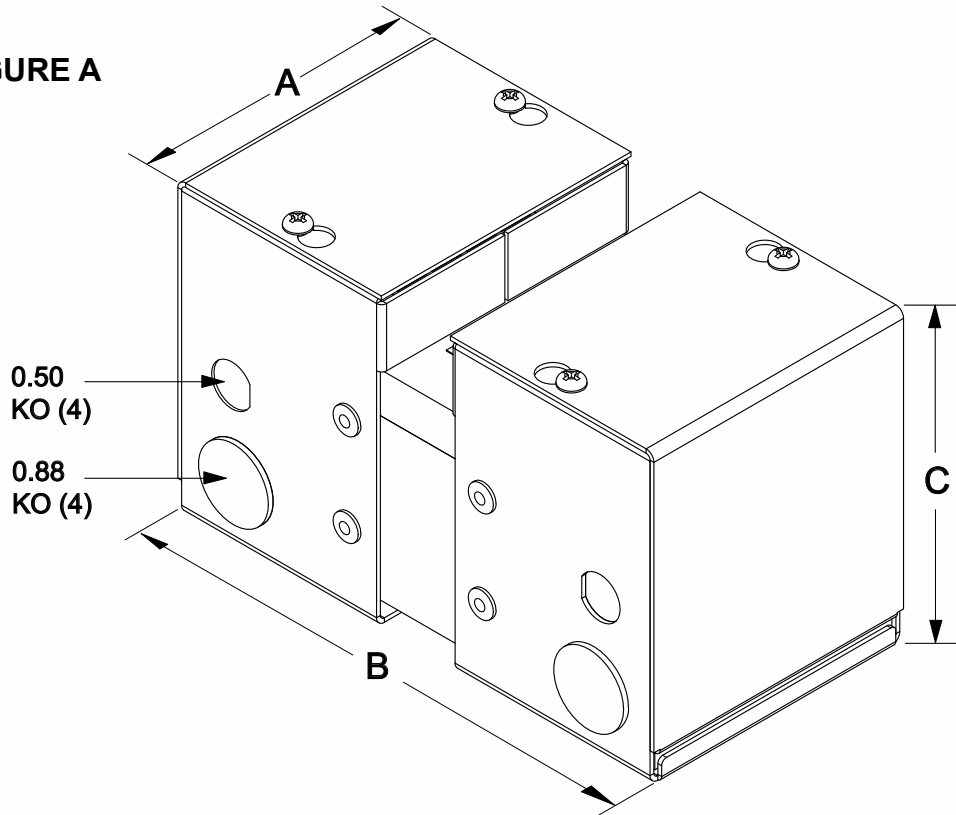

FIGURE B

