



### Main

Range of Product	Harmony iPC
Product or Component Type	Multi-touch screen
Processor Name	Intel Atom E3827 dual core 1.75 GHz
Chipset type	Intel Atom SoC
Free slots	1 CFast
Display size	10.1 inch
Display colour	267000 colours
Luminance	27.87 fc (300 cd/m <sup>2</sup> )
Pixel resolution	4096 x 4096
Video controller type	Intel HD Graphics
Software package	EcoStruxure secure connect advisor annual subscription cyber security license not included EcoStruxure Operator Terminal Expert run time HMI license not included EcoStruxure Machine SCADA Expert run time HMI/SCADA on configured offer only EcoStruxure augmented operator advisor server augmented operator license not included

### Complementary

Number of points	5
Terminal type	Touchscreen display
Memory type	4 GB RAM DDR3 internal
Data storage equipment	CFast card
Aspect ratio	16:9
Display Type	Colour TFT LCD LED
Display Resolution	1280 x 800 pixels WSVGA
Backlight lifespan	50000 hours
View angle horizontal x vertical	160 x 160°
Touch panel	Projected capacitive technology (PCT)
Type of cooling	Fanless Passive
Watchdog timer	1...255 ms
[Us] rated supply voltage	24 V DC +/- 20 % 100...240 V AC with additional adaptor HMIYPSOMAC1
Line Rated Current	1.9 A
Mechanical robustness	Hardness anti-scratch 7H
Local signalling	Buzzer For on LED (green) For stand-by LED (orange)
Function Available	Operate with water on screen
Width	11.15 in (283.1 mm)
Height	7.96 in (202.3 mm)
Depth	2.41 in (61.3 mm)
Cut-out dimensions	274.6 (+/- 0.7) x 193.8 (+/- 0.4)
Net Weight	5.51 lb(US) (2.5 kg)
Display size	10" wide multi-touch
Main type	Optimised

The information provided in this documentation contains general descriptions and/or technical characteristics of the performance of the products contained herein. This documentation is not intended as a substitute for and is not to be used for determining suitability or reliability of these products for specific user applications. It is the duty of any such user or integrator to perform the appropriate and complete risk analysis, evaluation and testing of the products with respect to the relevant specific application or use thereof. Neither Schneider Electric Industries SAS nor any of its affiliates or subsidiaries shall be responsible or liable for misuse of the information contained herein.

## Environment

IP degree of protection	Front panel IP66
Product Certifications	RCM[RETURN]AS/NZS[RETURN]CCC[RETURN]EAC[RETURN]CE[RETURN]C-tick
Standards	FCC Part 15 class A UL 60950 CISPR 11 IEC 61000-6-2 IEC 60950 IEC 61000-6-4 CSA C22.2 No. 60950
Directives	2006/95/EC - low voltage directive 2004/108/EC - electromagnetic compatibility
Pollution degree	2
Ambient air temperature for operation	32...131 °F (0...55 °C) SSD 32...131 °F (0...55 °C) Cfast card 32...113 °F (0...45 °C) HDD 32...113 °F (0...45 °C) Mini PCIe
Ambient air temperature for storage	-4...140 °F (-20...60 °C)
Relative Humidity	10...95 % non-condensing
Operating altitude	2000
Vibration resistance	1 gn 5...500 Hz)HDD 2 gn 5...500 Hz)SSD 2 gn 5...500 Hz)Cfast card

## Ordering and shipping details

Category	22575-MAGELIS MC3
Discount Schedule	MC3
GTIN	3606480853388
Returnability	No
Country of origin	US

## Packing Units

Unit Type of Package 1	PCE
Number of Units in Package 1	1
Package 1 Height	2.40 in (6.1 cm)
Package 1 Width	7.95 in (20.2 cm)
Package 1 Length	11.14 in (28.3 cm)
Package 1 Weight	5.51 lb(US) (2.5 kg)
Unit Type of Package 2	CAR
Number of Units in Package 2	1
Package 2 Height	23.03 in (58.5 cm)
Package 2 Width	8.66 in (22.0 cm)
Package 2 Length	28.74 in (73.0 cm)
Package 2 Weight	9.92 lb(US) (4.5 kg)

## Offer Sustainability

California proposition 65	WARNING: This product can expose you to chemicals including: Lead and lead compounds, which is known to the State of California to cause cancer and birth defects or other reproductive harm. For more information go to <a href="http://www.P65Warnings.ca.gov">www.P65Warnings.ca.gov</a>
EU RoHS Directive	Not applicable, out of EU RoHS legal scope
Mercury free	Yes
China RoHS Regulation	 <a href="#">China RoHS Declaration</a>
WEEE	The product must be disposed on European Union markets following specific waste collection and never end up in rubbish bins.

Dimensions

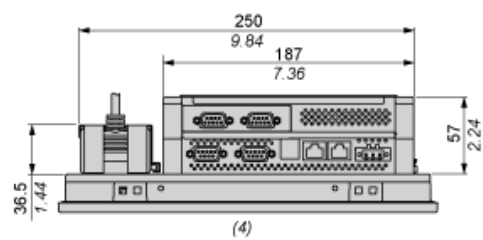
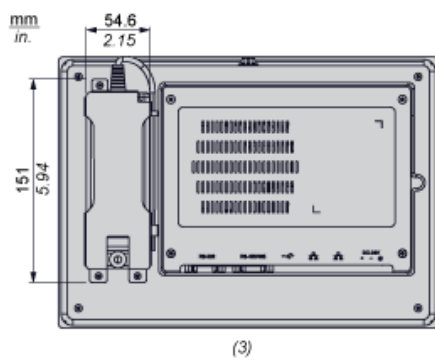
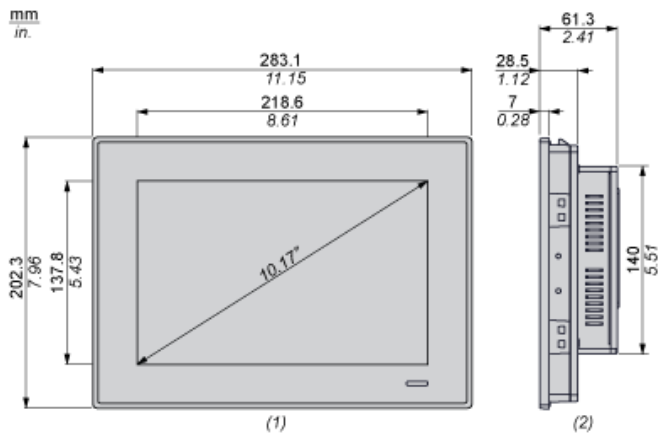

- (1) Front view
- (2) Right view
- (3) Back view
- (4) Bottom view

Spacing Requirements

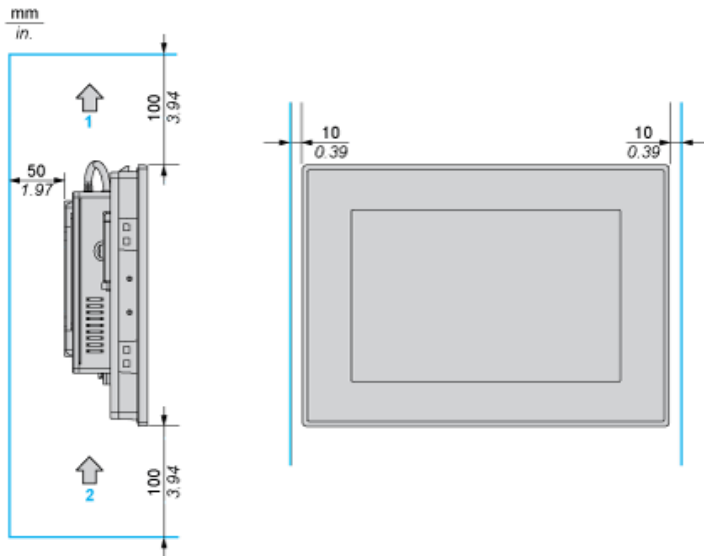

- 1 : Air out
- 2 : Air in

Mounting Orientation

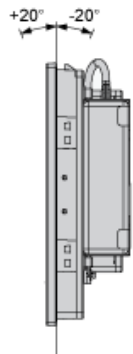

Panel Cut Dimensions

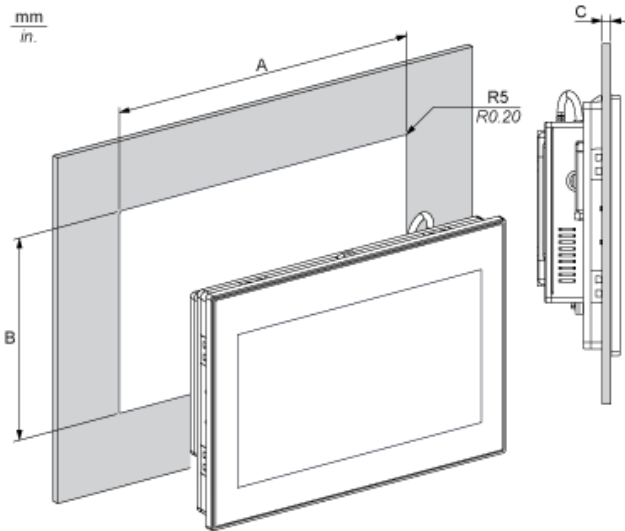

A		B		C		R	
mm	in.	mm	in.	mm	in.	mm	in.
274.6	10.81	193.8	7.63	2...6	0.08...0.23	5	0.20