

UR20-4AI-RTD-DIAG

Weidmüller Interface GmbH & Co. KG

Klingenbergstraße 26

D-32758 Detmold

Germany

www.weidmueller.com

Product image



Available for TC and RTD; 16-bit resolution; 50/60 Hz suppression

The involvement of thermocouple and resistance-temperature sensors is indispensable for a variety of applications. Weidmüller's 4-channel input modules are suited for all common thermocouple elements and resistance temperature sensors. With an accuracy of 0.2% of the measurement-range end value and a resolution of 16 bit, cable break and values above or below the limit value are detected by means of individual channel diagnostics. Additional features such as an automatic 50 Hz to 60 Hz suppression or external as well as internal cold-junction compensation, as available with the RTD module, round off the scope of function.

The module electronics supply the connected sensors with power from the input current path (U_{IN}).

General ordering data

Version	Remote I/O module, IP20, Analog signals, Temperature, RTD
Order No.	1315700000
Type	UR20-4AI-RTD-DIAG
GTIN (EAN)	4050118118872
Qty.	1 pièce(s)
Replacement parts	1350930000 1347290000 1484040000

UR20-4AI-RTD-DIAG

Weidmüller Interface GmbH & Co. KG

Klingenbergstraße 26

D-32758 Detmold

Germany

www.weidmueller.com

Caractéristiques techniques

Dimensions and weights

Depth	76 mm	Depth (inches)	2,992 inch
Height	120 mm	Height (inches)	4,724 inch
Width	11,5	Width (inches)	0,453 inch
Mounting dimension - height	128 mm	Net weight	91 g

Temperatures

Storage temperature	-40 °C ... +85 °C	Operating temperature	-20 °C ... +60 °C
---------------------	-------------------	-----------------------	-------------------

analogue inputs

Accuracy	0.2% FSR / 0.3% FSR for Ni sensors / 0.6% FSR for Cu10	Conversion time	adjustable, 36...240 ms
Individual channel diagnosis	Yes	Internal resistance U	1 MΩ
Measured temperature value, max.	850 °C	Measured temperature value, min.	-200 °C
Module diagnosis	Yes	Number of analogue inputs	4
Resolution	16 Bit	Reverse polarity protection	Yes
Sensor connection	2-wire, 3-wire, 4-wire	Temperature coefficient	≤ 50 ppm/K
Type	Pt100, Pt200, Pt500, Pt1000, Ni100, Ni120, Ni 200, Ni500, Ni1000, Cu10, 40Ω, 80Ω, 150Ω, 300Ω, 500Ω, 1kΩ, 2kΩ, 4kΩ		

Connection data

Type of connection	PUSH IN	Wire connection cross section, finely stranded, max.	1,5 mm ²
Wire connection cross section, finely stranded, min.	0,14 mm ²	Wire cross-section, finely stranded, max. (AWG)	AWG 16
Wire cross-section, finely stranded, min. (AWG)	AWG 26	Wire cross-section, solid, max.	1,5 mm ²
Wire cross-section, solid, max. (AWG)	AWG 16	Wire cross-section, solid, min.	0,14 mm ²
Wire cross-section, solid, min. (AWG)	AWG 26		

General data

Air humidity (operation)	10% to 95%, non-condensing as per DIN EN 61131-2	Air humidity (storage)	10% to 95%, non-condensing as per DIN EN 61131-2
Air humidity (transport)	10% to 95%, non-condensing as per DIN EN 61131-2	Air pressure (operation)	≥ 795 hPa (height ≤ 2000 m) as per DIN EN 61131-2
Air pressure (storage)	1013 hPa (height 0 m) to 700 hPa (height 3000 m) as per DIN EN 61131-2	Air pressure (transport)	1013 hPa (height 0 m) to 700 hPa (height 3000 m) as per DIN EN 61131-2
Pollution severity	2	Rail	TS 35
Shock	15 g over 11 ms, half sinus wave, acc. to IEC 60068-2-27	Surge voltage category	II
Test voltage	500 V	UL 94 flammability rating	V-0
Vibration resistance	5 Hz ≤ f ≤ 8.4 Hz: 3.5-mm amplitude as per IEC 60068-2-6, 8.4 Hz ≤ f ≤ 150 Hz: 1 g acceleration as per IEC 60068-2-6		

Date de création 26 novembre 2024 13:58:07 CET

Niveau du catalogue 26.11.2024 / Toutes modifications techniques réservées

2

UR20-4AI-RTD-DIAG

Weidmüller Interface GmbH & Co. KG

Klingenbergstraße 26

D-32758 Detmold

Germany

www.weidmueller.com

Caractéristiques techniques

Power supply

Current consumption from I_{IN} (the respective power segment)	< 20 mA	Current consumption from I_{SYS} , typ.	8 mA
Reverse polarity protection	Yes	Voltage supply	24 V DC +20 %/ -15 %, via the system bus

System data

Diagnostic data	20 Byte	Field bus protocol	CANopen, DeviceNet, EtherCAT, EtherNet/IP, Modbus/TCP, PROFINET IRT, PROFIBUS DP-V1, POWERLINK
Galvanic isolation	DC 500 V between current paths	Interface	u-remote system bus
Module type	Temperature module	Parameter data	32 Byte
Process data	8 Byte	Transmission speed of system bus, max.	48 Mbit

Classifications

ETIM 6.0	EC001596	ETIM 7.0	EC001596
ETIM 8.0	EC001596	ETIM 9.0	EC001596
ECLASS 9.0	27-24-26-01	ECLASS 9.1	27-24-26-01
ECLASS 10.0	27-24-26-01	ECLASS 11.0	27-24-26-01
ECLASS 12.0	27-24-26-01	ECLASS 13.0	27-24-26-01
ECLASS 14.0	27-24-26-01		

UR20-4AI-RTD-DIAG

Weidmüller Interface GmbH & Co. KG
 Klingenbergstraße 26
 D-32758 Detmold
 Germany

www.weidmueller.com

Caractéristiques techniques

Tender specification sheets

Long specification	<p>4AI-RTD-DIAG 4-channel analogue input module Automatic 50-60 Hz suppression Internal or external cold-junction compensation possible For all conventional sensors (PT, Ni, Cu10) Connection system: PUSH-IN Dimensions (HxWxD): 120 mm (with lever: 128 mm), 11.5 mm, 76 mm Module status: display via collective message, LED at the top of the module Channel status: indication directly at the contact point Weight: 90.5 g Module diagnosis: yes Individual channel diagnosis: yes Reverse-polarity protection: yes Operating temperature: -20°C - +60°C Process data: 8 bytes Parameter data: 32 bytes Diagnostic data: 20 bytes Galvanic isolation: between field and system bus Supply voltage: 24 VDC +25% / -15% Internal current consumption: 8 mA Supply current consumption: 20 mA Temperature coefficient: 50 ppm/ K Accuracy: 0.2% FSR, 0.3% FSR with Ni sensors, 0.6% FSR with Cu10 Conversion time: 36 - 240 ms (adjustable) Internal resistance I: > 1 MΩ Resolution: 16 bits Brand: Weidmüller Type: UR20-4AI-RTD-DIAG</p>
--------------------	---

Environmental Product Compliance

RoHS Compliance Status	Compliant with exemption
RoHS Exemption (if applicable/known)	7a, 7cI
REACH SVHC	Lead 7439-92-1
SCIP	82327f13-cd27-455a-ab5b-a62e1996dcf8

UR20-4AI-RTD-DIAG

Weidmüller Interface GmbH & Co. KG
 Klingenbergstraße 26
 D-32758 Detmold
 Germany

www.weidmueller.com

Caractéristiques techniques

Approvals

Approvals



ROHS	Conform
UL File Number Search	UL Website
Certificate no. (cULus)	E141197
Certificate no. (cULusEX)	E223527

Downloads

Approval/Certificate/Document of Conformity	KC certificate Compass safe distance certificate Lloyds Register certificate DNV certificate ABS certificate RINA certificate Bureau Veritas - Type Approval Certificate PRS (Polish Register of Shipping) NIPPON KAIJI KYOKAI Certificate - ClassNK DEMKO 15ATEX1525X CCS certificate CCS certificate UKCA Declaration of Conformity - EN CE Declaration of Conformity - DE
Engineering Data	CAD data – STEP Compatibility information – Combinability of UR20
Product Change Notification	Release-Notes - Firmware
Software	Firmware – Current firmware UR20-4AI-RTD-DIAG UR20-4AI-TC-DIAG Firmware – Archive firmware UR20-4AI-RTD-DIAG UR20-4AI-TC-DIAG
User Documentation	Handbuch u-remote DE Manual u-remote EN
Catalogues	Catalogues in PDF-format

UR20-4AI-RTD-DIAG

Weidmüller Interface GmbH & Co. KG
 Klingenbergstraße 26
 D-32758 Detmold
 Germany

www.weidmueller.com

Dessins

Block diagram

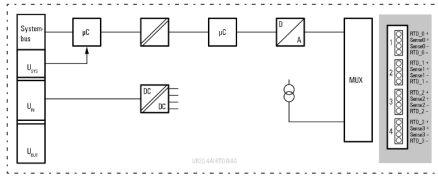

Connection diagram

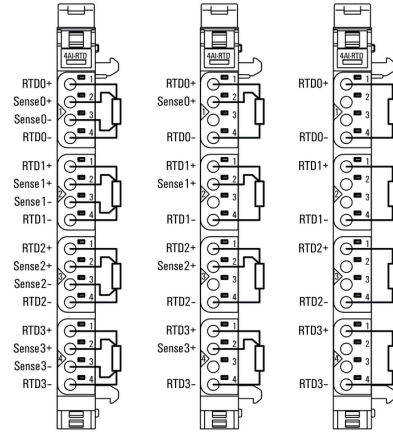

Explanation of abbreviations

Analogue input modules

